



Technical Bulletin TB-06

September 20, 2017

Issue Description:

The proper use of pneumatic coil nailers for the installation of asphalt shingles.

Recommendations:

Proper setup and use of pneumatic coil nailers is critical for correct installation of Owens Corning asphalt shingles. Improper use of pneumatic coil nailers may lead to shingle damage and/or shingle failures during a high-wind event. Ensuring proper nail gun setup will:

- Prevent over-driving the nails, which can cause the nail head to blow through the shingle.
- Prevent under-driving the nails, which can prevent shingles from laying flat and sealing properly.

Key Considerations:

- Use regulated compressed air and never apply more air pressure than is necessary to properly drive the fasteners.
- Most pneumatic coil nailers operate at optimum efficiency when the pressure is set between 80 and 95 psi.
- Most coil nailers are equipped with a depth adjustment knob. Adjust the settings for the nail heads to be driven flush.
- The startup and cutout pressures on the compressor should be set to maintain optimum operating pressure in the compressor tank at all times.
- Air hose length and diameter should be considered when setting psi at regulator.
- Operating more than one coil nail gun from a single compressor may affect how well the fasteners penetrate the shingles.
- Use corrosion resistant 11 or 12-gauge nails with a minimum $\frac{3}{8}$ -inch diameter heads, complying with ASTM F1667.
- Unusually cold or hot temperatures may require additional tuning of the compressor for optimum nail driving performance.
- Always read and be familiar with the operating instructions for the compressor and nail gun.
- When using pneumatic coil nailers, always **ensure that the nail is driven flat and flush with the shingle.**
- **Any shingle into which an overdriven fastener has been installed** must be repaired by either replacing the shingle or covering the fastener with asphalt roofing cement and installing an additional fastener within 1-inch of the overdriven fastener.

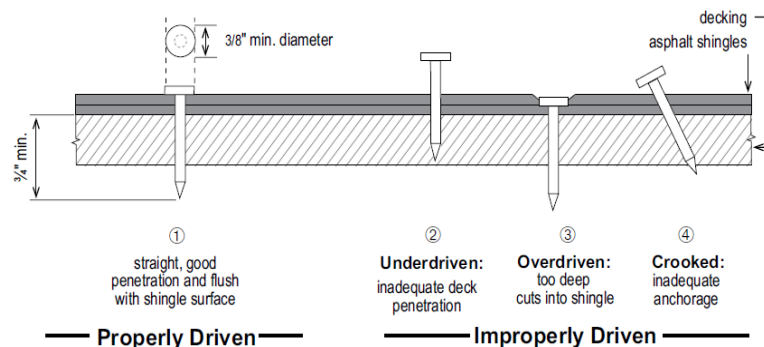

Please contact 419-248-6557 for additional information. Email: gettech@owenscorning.com

Disclaimer of Liability

Technical information contained herein is furnished without charge or obligation and is given and accepted at recipient's sole risk. Because conditions of use may vary and are beyond our control, Owens Corning makes no representation about, and is not responsible or liable for the accuracy or reliability of data associated with particular uses of any product described herein.



OWENS CORNING SCIENCE AND TECHNOLOGY, LLC
ONE OWENS CORNING PARKWAY
TOLEDO, OHIO 43659
1-800-GET-PINK®
www.owenscorning.com

Pub. No. 10022498. Printed in U.S.A. July 2014. THE PINK PANTHER™ & ©1964-2014 Metro-Goldwyn-Mayer Studios Inc. All Rights Reserved. The color PINK is a registered trademark of Owens Corning. ©2014 Owens Corning. All Rights Reserved.



