

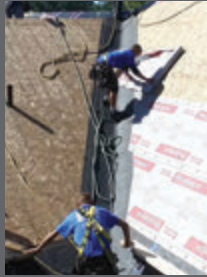

Owens Corning Roofer's Guide to Roof Installation



^ Excludes non-Owens Corning® roofing products such as flashing, fasteners and wood decking.



Dear Owens Corning Roofing Contractor Network Member:

Thank you for your business with Owens Corning. As America's most trusted brand* we take pride in providing homeowners the peace of mind that they have chosen the right roofing system and the right professional contractor for the job. Customers trust their homes and business to Owens Corning Roofing Contractor Network members because they have the confidence in the quality of your work and products you install – all backed by one of the most trusted names in the building materials industry.

To that end, we're pleased to provide you with the new Owens Corning Roofer's Guide to Roof Installation. The purpose of this guide is to provide you with quality instructions and detailed procedures on roof application and product installations following the Asphalt Roofing Manufacturers Association (ARMA) guidelines. This guide is part of Owens Corning Roofing's Quality Assurance Initiative which was carefully developed to enhance our ability to support warranty obligations, improve the overall homeowner experience and achieve accountability across the Owens Corning Roofing Contractor Network for upholding high standards on every job.

Please keep this reference guide handy on the job site as a resource for the correct – and safe – installation of all Owens Corning® Roofing products. It is no accident that everything we do begins with safe work conditions.

Thank you,
Quality Assurance Initiative Team

Roofing Safety

SAFETY

The best form of accident insurance is accident prevention. It's important to do the following with each new job:

- Inspect each job site before the work begins for possible hazards
 - Overhead electrical lines
 - Unstable ground conditions for ladders or scaffolding
 - Others
- Make sure all workers are aware of any hazards before beginning the job
- Adhere to OSHA safety and fall-protection standards

OSHA

1926.501(b)(10)

- "Roofing work on Low-slope roofs." Except as otherwise provided in paragraph (b) of this section, each employee engaged in roofing activities on low-slope roofs, with unprotected sides and edges 6 feet (1.8 m) or more above lower levels shall be protected from falling by guardrail systems, safety net systems, personal fall arrest systems, or a combination of warning line system and guardrail system, warning line system and safety net system, or warning line system and personal fall arrest system, or warning line system and safety monitoring system. Or, on roofs 50-feet (15.25 m) or less in width (see Appendix A to subpart M of this part), the use of a safety monitoring system

1926.500(a)(1)

- This subpart sets forth requirements and criteria for fall protection in

Safety is everyone's responsibility

- Have a safety plan and checklist and use them
- Create policies and procedures to ensure safe roofing practice
- Help employees know what to do in case of an accident
- Help your roofing business reduce costs by preventing accidents
- Wear footwear that provides good traction such as rubber-soled shoes with good ankle support
- Do not attempt to work in bad weather or on a wet roof
- Do not touch wires crossing over the roof.
- Extension ladders should have proper locking devices and be in good condition
- Place the ladders at safe angles (1 ft out per 4 ft up) on stable foundations
- **Ladders must extend past the edge of the roof by 3' minimum**
- Brace ladders used on the roof deck to the roof structure
- Avoid leaning away from a ladder to work. Move the ladder as required
- As the work proceeds, keep the deck clear of unnecessary debris to avoid tripping hazards
- Always use the proper tools for each segment of the work

Roofing System Inspections

construction workplaces covered under 29 CFR part 1926. Exception: The provisions of this subpart do not apply when employees are making an inspection, investigation, or assessment of workplace conditions prior to the actual start of construction work or after all construction work has been completed.

Remember – Safe roofing is no accident!

- A quality job is dependent on roofing system inspections:
 - Before the job, with the homeowner
 - During the job while installation is in progress
 - After the job is completed – a final walk through with the home owner
- Develop an inspection checklist
- Before the job
 - Inspect the roofing system with the homeowner
 - Document what you see (photos or written notes)
 - Check the roof (measurements, projections, flashings, slope, vents, etc.)
 - Check the attic (sheathing, ventilation, insulation)
 - Rotten wood, stains, mold, rust on nail tips, blocked soffit vents, other vents, insulation type and level, etc.)
 - Check the ceilings (stains, mold, cracking)
 - Check the yard (plants, shrubs, trees, decks, etc.)
 - Prepare your estimate, discuss with owner
- During the job
 - Safety – set-up, ladders, fall protection, etc.
 - Tear-off and waste disposal, cleanliness
 - Roof loading, equipment/tools, hoses, etc
 - Underlayment, measurements, chalk lines, drip edges, starter strips
 - Shingle application, bundle staging, alignment, fastening, hip and ridge caps, vents, etc.
 - Flashing details, use of roofing cements
- After the job, Final Inspection
 - Does the roof look good?

Roofing Applications

- Debris cleaned up
 - Roof lays flat (fix “fishmouths”)
 - Replace broken or scuffed shingles
 - Shingles are sealed down
 - Flashings are secure
- With the homeowner, check out the roof and the grounds – get his/her approval before leaving
- Photos
 - Neighbors

DECK REQUIREMENTS

- Minimum 6" width, 25/32" minimum thickness wood sheathing
- Minimum 3/8" plywood sheathing or 7/16" OSB
- Sheathing spaced minimum 1/8" and maximum 1/4"
- Check local building codes

“Sumping” or Deck Deflection (Sag)

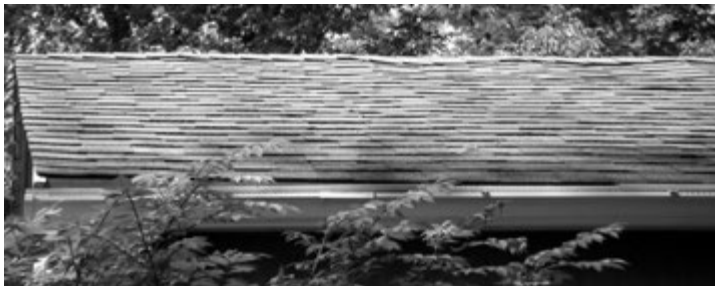

METAL DRIP EDGE

- Recommended along rake and eave - check local building codes
- Apply directly to deck along eave unless otherwise specified by local codes
- Apply over underlayment along rake
- With drip edge—shingles could be flush to edge or overhang 1/4" to 3/4"
- Without drip edge—shingles should overhang 1/2" to 1"

2012 International Residential Code now requires drip edge at the eaves and rake edge of the roof. The IRC has required drip edge since the 2009 edition.

Drip Edges provide efficient water shedding at the rakes and eaves and protect the underlying wood from rotting. Drip edges should be made of a corrosion-

resistant material that extends approximately 3" back from the roof edges and bends downward over them. Apply the drip edge underneath the underlayment along the eaves and over the underlayment on the rakes. Figure 3-5 details the placement and fastening of drip edges in combination with underlayment. The use of a drip edge is strongly recommended and may be required by local building codes. If no drip edge or a wood strip is used as a drip edge then all rake and eave overhangs should be $\frac{1}{2}$ " to 1".

Figure 1 Application of Drip Edge at Rake and Eaves

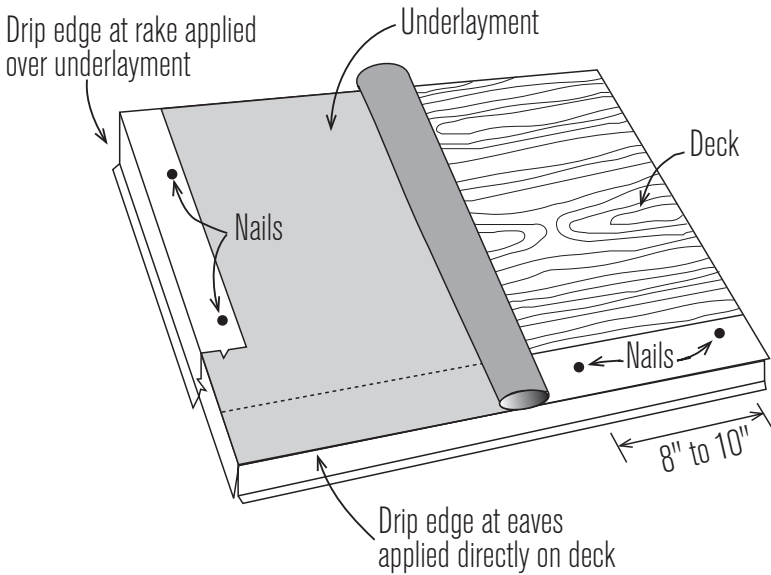

On Rake Edge:

1. All regular underlayments go under the drip edge
2. Starter and shingles should overhang the drip edge $\frac{1}{4}$ " to $\frac{3}{4}$ "

On Eaves:

1. All underlayment goes on top of drip edge unless otherwise specified by local codes.
2. Shingles should overhang the drip edge $\frac{1}{4}$ " to $\frac{3}{4}$ ".

Figure 2 Recommended Drip Edge

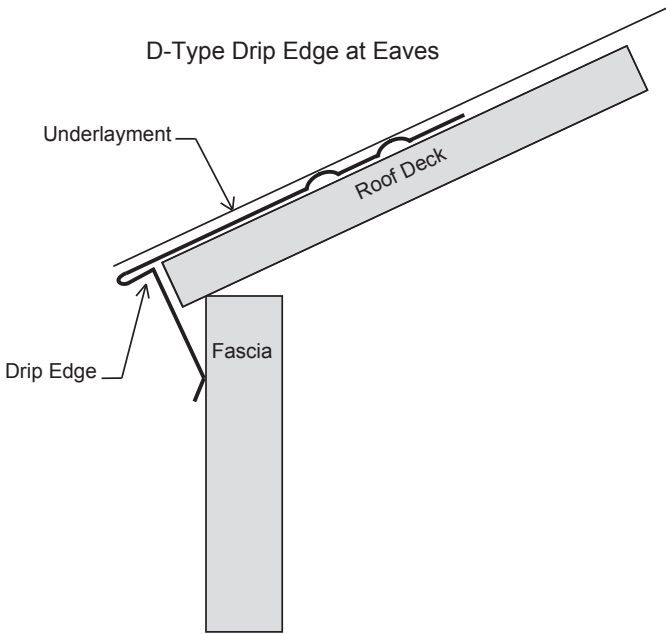
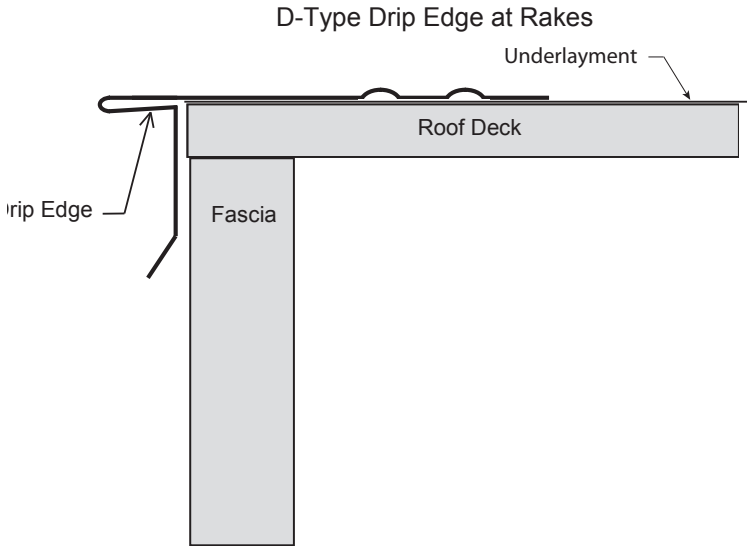

Figure 3 Acceptable Drip Edge



FASTENER REQUIREMENTS

- Use galvanized steel, stainless steel, or aluminum nails with minimum 12 gauge shank and $\frac{3}{8}$ " diameter head
- Fasteners should comply with ASTM F1667
- Check local building codes.
- Fasteners must penetrate $\frac{3}{4}$ " into wood decking
- Decks less than $\frac{3}{4}$ " thick—fastener must penetrate completely through minimum $\frac{1}{8}$ "

Figure 4 Fastening

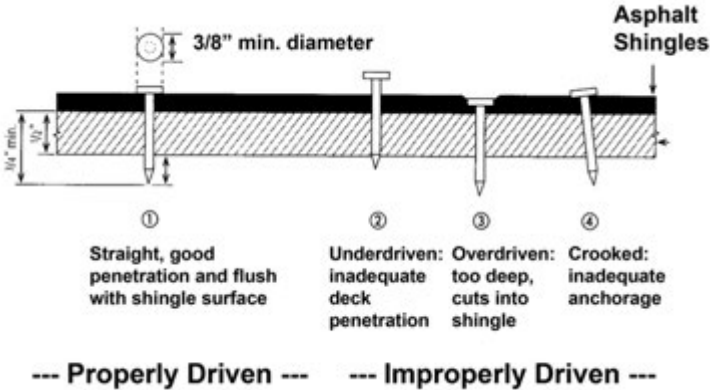

Quantity of Fasteners:

- The number of fasteners as shown in printed installation instructions
- Six fasteners required for mansard-hand sealing is also required
- Check local building codes

Figure 5 Mansard Roof Hand Sealing Example

6 Nail Pattern

Esquema con 6 clavos

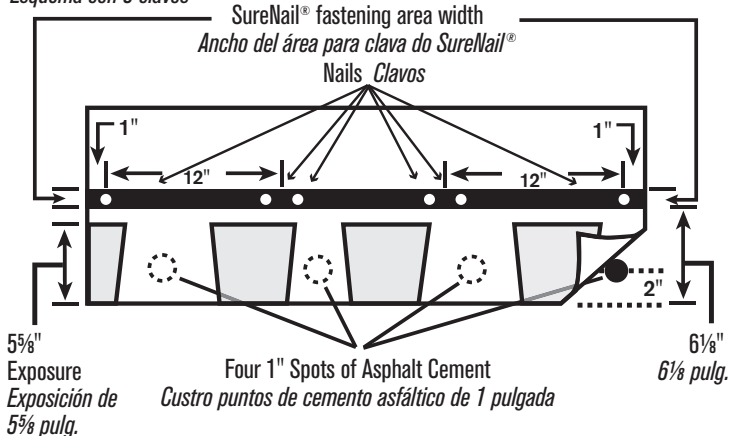

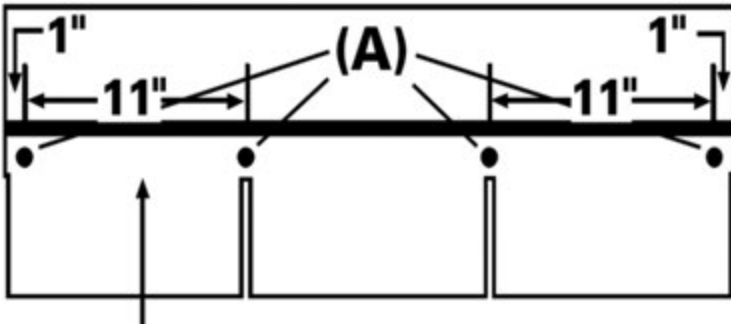

5" Exposure

Figure 6

Oakridge® shingles

4-Nail Configuration
Configuración de 4 clavos

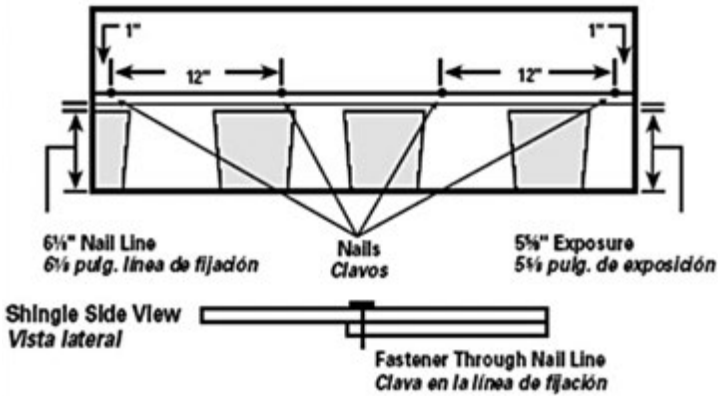
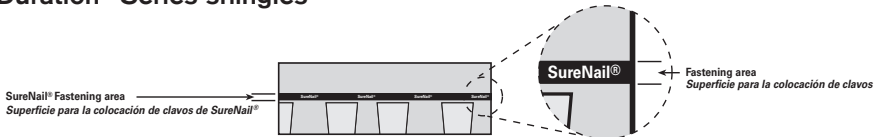
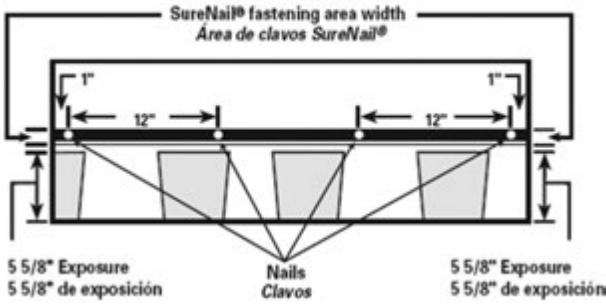

Figure 7

Duration® Series shingles



4 Nail Pattern
Esquema de 4 clavos



Shingle Exposure

- Imperial 3 Tab – 5" exposure
- Metric 3 Tab – 5 5/8" exposure
- Laminates - 5 5/8" exposure
- Acceptable tolerance: Plus or minus 1/8"

PROPER UNDERLAYMENT APPLICATION: SLOPES ≥ 4:12

Some building codes have specific requirements for underlayment and/or ice dam. The requirements of these codes must be followed.

No roof is better than the quality of its installation. Asphalt roofing materials are no exception. They are designed to give years of service when applied carefully and correctly.

Underlayment material used beneath roofing shingles is recommended to comply with one of the following: ASTM D226, ASTM D4869, ASTM D6757, ASTM D1970, or as recommended by the individual shingles manufacturer

Figure 8

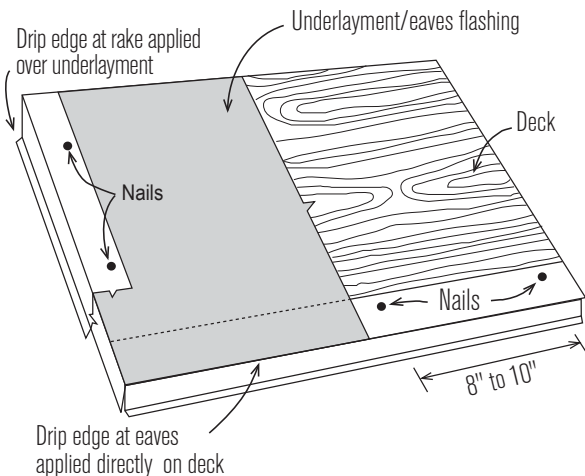
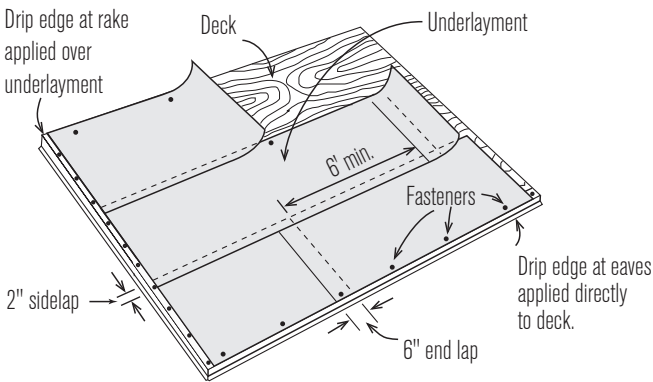

Figure 9 Application of Underlayment or Inclines 4/12" or Greater



UNDERLAYMENT LOW SLOPE: 2:14 ≤ 4:12

Asphalt shingles may be used on slopes ranging from 2"-4" per foot if special procedures are followed. Never use shingles on slopes lower than 2" per foot. Low slopes can lead to problems because water drains slowly from these slopes, creating the greater possibility of water backup and damage from ice dams. The special application method described below for applying shingles on low slopes ensures that the roof remains weather-tight.

Underlayment

On low slope applications, cover the deck with two layers of non-perforated asphalt saturated felt or one layer of an appropriate self-adhering modified bitumen membrane. Begin by fastening a 19" wide strip of underlayment placed along the eaves. Place a full width sheet over the starter, with the long edge placed along the eaves and completely overlapping the initial starter course. All succeeding courses will be a minimum of 36" wide and should be positioned to overlap the preceding course by 19". Secure each course by using only enough fasteners to hold it in place until the shingles are applied. End laps should be 12" wide and located at least 6 feet from end laps in the preceding course. Instructions are different for self-adhering products because they are not required to be installed in two layers.

Also, if felt is used it is required to be cemented together per Figure 10.

Figure 10 Application of Underlayment on Low Slopes Where Ice Damming Along the Eave is Anticipated

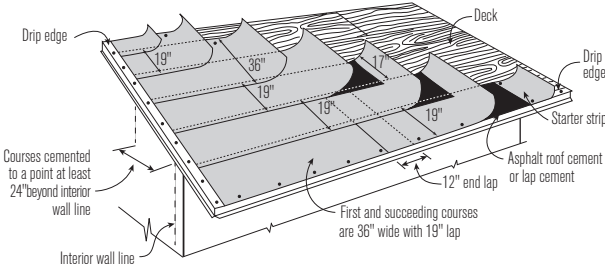
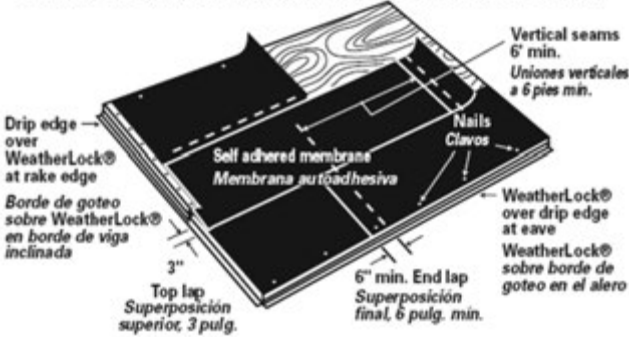

Figure 11 Low Slope WeatherLock® over the entire roof deck

Slopes 2" in 12" to less than 4" in 12"
 Pendientes de 2 pulg. cada 12 pulg., hasta menos de 4 pulg. cada 12 pulg.



EAVES FLASHING FOR ICE DAM PROTECTION

Ice Dams are formed by the continual thawing of snow over the warmer portions of the roof and refreezing over the cold eaves. The ice dams can cause the back up of water and slush under the exposed roofing material and cause damage to the structure. An ice barrier that consists of at least two layers of underlayment cemented together or of a self-adhering polymer modified bitumen sheet shall be used in lieu of normal underlayment and extend from the lowest edge of all roof surfaces to a point at least 24 inches inside the exterior wall line of the building.

Exception: Detached accessory structures that contain no conditioned floor area.

The recommended method is to use self-adhering modified bitumen membrane that complies with ASTM D1970, or as approved by the shingle manufacturer or local code. The self-adhered membrane is applied directly to the deck and is applied at a width to extend up the roof from the eaves or rake edge to a point at least 24" inside the interior wall line (heated space). If the membrane is not wide enough to reach that point, install additional course(s) of membrane as needed, overlapping the previous course by 2" or as specified by manufacturer.

Note: When a self-adhered eave and flashing membrane is used as underlayment, no additional eave flashing application is required.

Self-adhered eave and flashing membranes are also excellent for use on ridges, hips, flashings and valleys, as well as around dormers, skylights and chimneys. Because most eave flashing materials are vapor retarders, they should not be used beyond recommended areas without proper ventilation. A lack of proper ventilation in these cases will result in the possibility of water vapor condensation under the roof deck.

Figure 12 Application of Self-Adhered Eave and Flashing Membrane

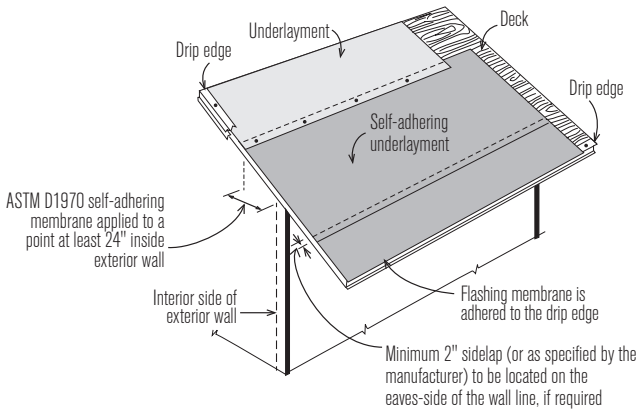
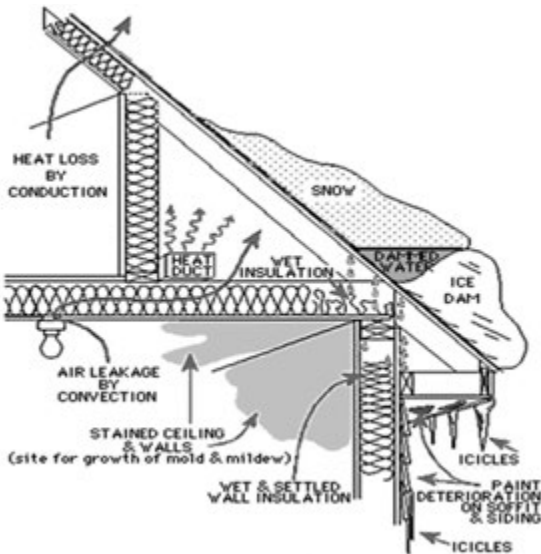

Figure 13 Cross section of a home with an Ice Dam



VALLEY CONSTRUCTIONS

Valleys are formed where two sloping roof planes meet at an angle. The sloping planes direct water toward the valley, concentrating the drainage along the joint and making it especially vulnerable to leakage. As a result, one of the most

important installation details for good roof performance is proper valley flashing. Consult the appropriate roofing manufacturers for recommendations on a particular applications

To install underlayment in a valley, first center a 36" wide strip of the appropriate underlayment in the valley and secure it with only enough nails to hold it in place or place a 36" wide strip of self-adhered membrane directly to the deck. Then trim the horizontal courses of felt underlayment applied on the roof to overlap the valley strip at least 6". (See Figure 14). In all valleys the underlayment or self-adhered membrane should be tight in the valley but not creased or wrinkled following application of the underlayment, roofs with multiple planes require the construction of one of three types of valleys: open, woven or closed cut. Regardless of the type of valley used, it must be smooth, unobstructed, of sufficient capacity to carry water away rapidly and capable of withstanding occasional backing up of water.

Following application of the underlayment, roofs with multiple planes require the construction of one of three types of valleys: open, woven or closed cut. Regardless of the type of valley used, it must be smooth, unobstructed, of sufficient capacity to carry water away rapidly and capable of withstanding occasional backing up of water.

Figure 14 Application of Underlayment in a Valley

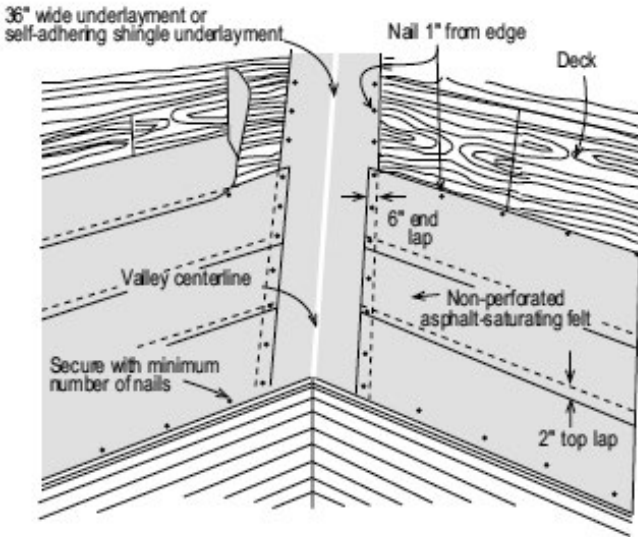

OPEN VALLEYS

The recommended flashing material is a 26-gauge galvanized metal or an equivalent corrosion resistant, non-staining material (check with shingle manufacturer and local code). The width should be no less than 24", but local building codes or shingle manufacturer may require a greater width. (See Figure 15)

Figure 15 Application of Corrosion Resistant Metal Flashing for an Open Valley

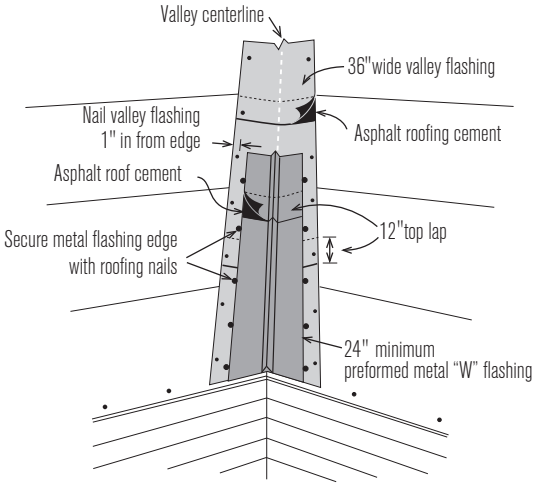
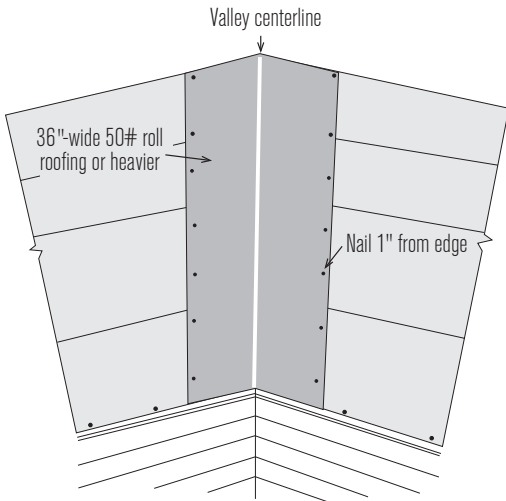

Figure 16 Application of Flashing for a Woven or Closed-Cut Valley



If the valley is covered with a minimum 36" wide self-adhered membrane that complies with ASTM D1970, adhered directly to the deck the valley is ready for the metal valley flashing. If the valley is covered with felt underlayment and additional layer of, #50 or heavier valley underlayment is required before the metal flashing is applied.

Center the strip in the valley, securing the non-self-adhered materials with only enough nails to hold it in place (See Figure 16). Nail the strip along a line 1" from the edges, first on one edge all the way up, then on the other while pressing

the flashing strip firmly and smoothly into the valley. Laps should be 12" and cemented.

Center the metal flashing in the valley. Trim the lower edge flush with the eaves drip edge. Install it up the entire length of the valley. If two or more strips of flashing are required, lap the upper piece over the lower so that drainage will be carried over the joint, not into it. The overlap should be 12" and fully bonded with asphalt roofing cement.

Use only enough nails to hold the strip in place. Nail along a line 1" from each edge. Start at one edge and work all the way up. Then return to nail the other side, pressing the flashing strip firmly into the valley at the same time. In areas of heavy rainfall it may be desirable to use a layer of self-adhered eave and flashing membrane (ice dam membrane) beneath the valley and over the initial valley flashing.

After the underlayment has been secured, install the recommended corrosion resistant metal in the valley. Secure the valley metal to the roof deck without puncturing, with roofing nails spaced 8"-12" apart. Overlaps should be 12" and cemented. The valley will be completed with shingle application.

SHINGLE APPLICATION

Starter Strip

The Starter Strip may be either a row of shingles trimmed to the shingle manufacturer's recommendations or a strip of mineral-surfaced roll roofing that is wider than the shingle exposure dimension. Pre-cut starter shingles are also available. The starter strip protects the roof by filling in the spaces under the shingle joints of the first course of shingles. It should overhang the eaves and rake edges by $\frac{1}{4}$ " to $\frac{3}{4}$ ". Where the drip edge extends out from the eaves and rakes, the shingles may be cut flush with the drip edge or extend out no more than $\frac{3}{4}$ ".

If self-sealing shingles are used for the starter strip, remove the tab portion of each shingle and position the remaining strip with the factory applied adhesive face up along the eaves. Trim at least 4" [Figure 17 shows 6" removed] from the end of the first shingle in the starter strip. Fasten the starter strips parallel to the eaves along a line $1\frac{1}{2}$ "-3" above the eaves. Position the fasteners so that they will not be exposed under the shingle ends in the first course (See Figure 17).

Figure 17 Application of Starter Strip

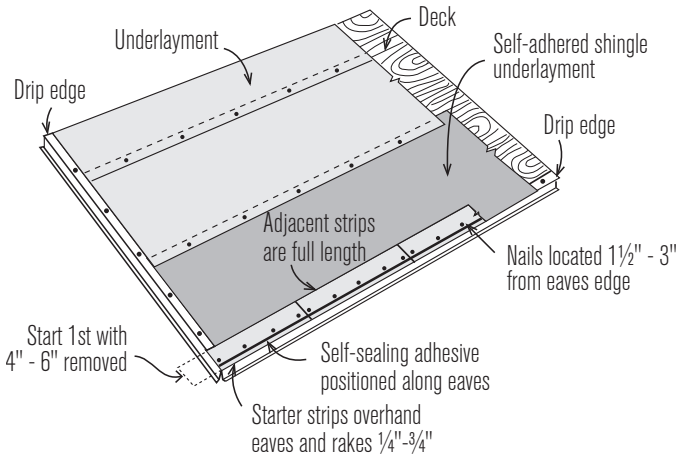

Applying the Shingles

The first course starts with a full shingle, while succeeding courses start with portions removed according to the style of shingle being applied.

By removing different amounts from the first shingle in each course, shingle joints or multiple thickness areas in one course do not line up directly with those of the course below, creating the desired pattern.

Figure 18 - 3 Course Repeat Pattern and Offset

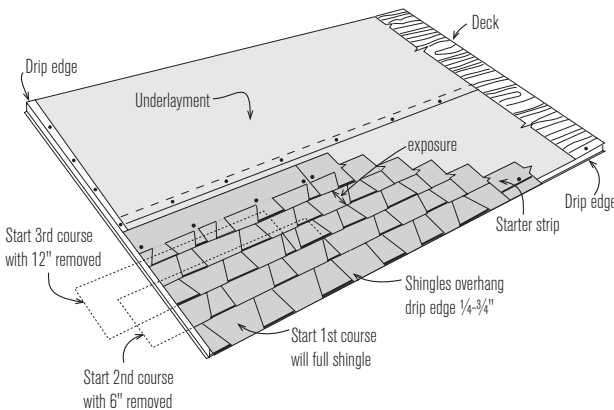

Racking



- Installer must work from several bundles of shingles to help reduce shade variation
- Installer must ensure that each shingle has the correct number of nails per the manufactures requirements
- Check local building codes.

Shading (Racking)



Valleys

Several different methods of treating valleys are possible including the open and closed cut methods. Open or closed cut valleys are the preferred method for laminated shingles. Open valleys are preferred for heavy weight and very thick shingles, because of the difficulty in forming the shingles to the valley to make a cosmetically appealing appearance with the woven or closed cut construction. For all the methods, valley flashing should be in place before shingle application is begun (See pages) except for open valleys around dormers where the valley flashing must overlap the top courses of shingles along the dormer sidewalls. Thoroughly working all valley materials well into the break of the valley prior to fastening is recommended.

Open Valleys

Snap two chalk lines, one on each side of the valley centerline over the full length of the valley flashing. Locate the upper ends of the chalk lines 6" apart at the ridge (i.e. 3" to either side of the valley centerline). The lower ends of the valley the chalk lines should diverge from each other at a rate of $\frac{1}{8}$ " per foot of valley length. Thus, for an 8' long valley, the chalk lines should be 7" apart at the eaves; for a 16' valley, they should be 8" apart. The minimum shingle overlap on each side of the metal valley is 6". (See Figure 18)

Figure 19 Application of Shingles in an Open Valley

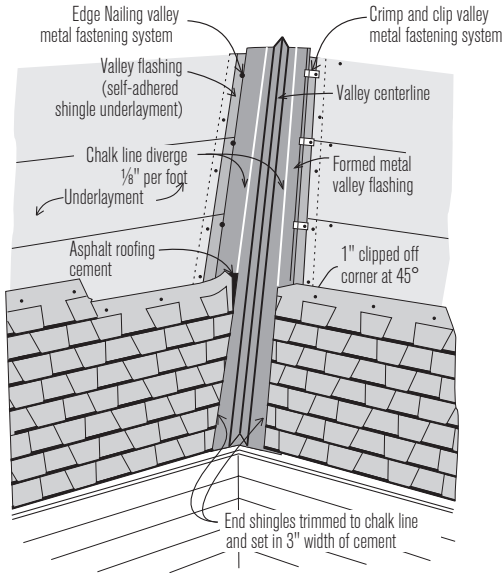

As shingles are applied toward the valley, trim the last shingle in each course to fit on the chalk line. Never use a shingle trimmed to less than 12" in length to finish a course running into a valley. If necessary, trim a section off the adjacent shingle in the course to allow a longer portion to be used. Clip 1" from the upper corner of the shingle on a 45° angle to direct water into the valley and prevent it from penetrating between the courses. Finally, to form a tight seal, cement the shingle to the valley lining with a 3" width of asphalt roofing cement (conforming to ASTM D 4586). There should be no exposed nails along the valley flashing.

Closed Cut Valleys

Note: The first course and only the first course of shingles from the intersecting roof surface should be woven with the first course of shingles on the starting tool.

With valley flashing already in place, apply the first course of shingles along the eaves of one of the intersecting roof planes and across the valley. The first course and only the first course of shingles from the intersecting roof surface

should be woven with the first course of shingles on the starting roof. For proper flow of water over the trimmed shingle, always start applying the shingles on the roof plane that has the lower slope or lesser height. Extend the end shingle at least 12" onto the adjoining roof. Do not make a joint in the valley. If a shingle falls short, add in section so that the joint occurs outside the line of the valley. Apply succeeding courses in the same manner, extending them across the valley and onto the adjoining roof. Press the shingles tightly into the valley. Use normal shingle fastening methods except that no fastener should be within 6" of the valley centerline and two fasteners should be placed at the end of each shingle crossing the valley

Figure 20 Shingle application in a closed cut valley

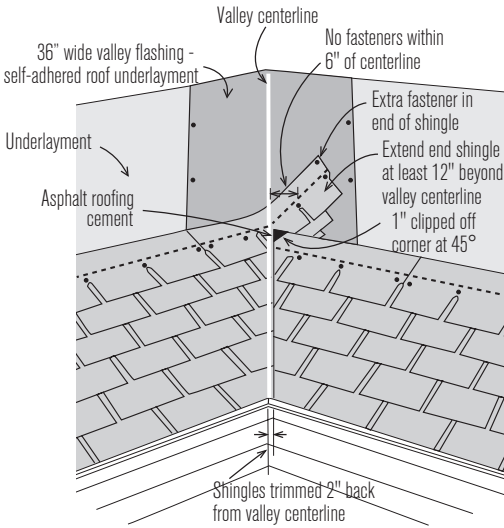
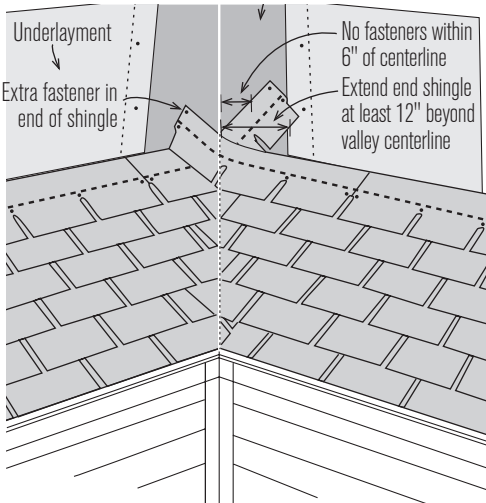

Figure 21 Woven Valley



Flashing Details

All areas on the roof surface where there is an intersection of roof planes or a projection through the roof surface (i.e., chimneys, vent stacks, dormer walls, etc.) require “flashing.” Flashing is the construction procedure necessary to make these areas watertight. Careful attention to flashing details is essential for proper leak-free roof performance. Some of the figures showing details may be shown as a strip shingle and/or as a laminated shingle. In most cases the application techniques are identical.

FLASHING AGAINST VERTICAL SIDEWALLS

Roof planes that butt against vertical walls at the end of shingle courses are best protected by metal “flashing shingles” placed over the end of each course. The method is called “step flashing.”

The metal flashing shingles are rectangular, 10" long and 2" wider than the expected exposure of the roofing shingles. For example, when used with shingles with a 5" exposure, they are 10" x 7". The 10" length is bent to extend 5" over the roof deck and 5" up the wall surface. Each flashing unit is placed up-roof from the exposed edge of the shingle that will overlap it so that it is not visible when the overlapping shingle is in place. (See Figure 22 & 23)

To install step flashing, place the first flashing unit over the end of the starter strip and position it so that the end shingle in the first course covers it completely. Secure the horizontal flange to the roof with two nails. Do not nail flashing to the wall as differential movement of the wall and roof could damage the seal. Then apply the first course of shingles up to the wall. Position the second step flashing strip over the end shingle in the first course 5" up from the butt or the same distance as the shingle exposure so that the end shingle in the second course covers it completely. Fasten the horizontal flange to the roof.

Figures 22 & 23 Application of Step Flashing

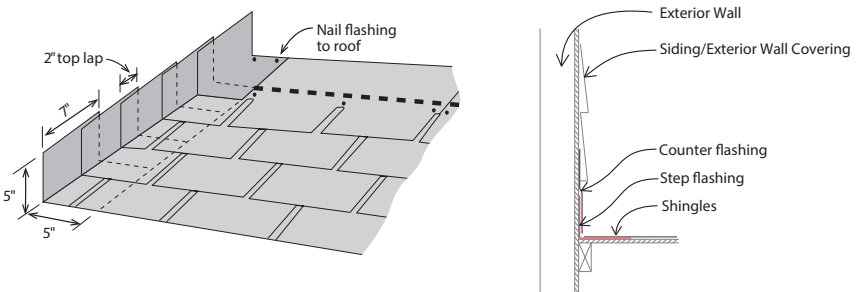

Figure 22

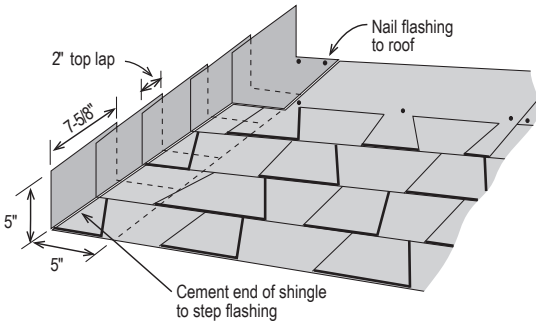
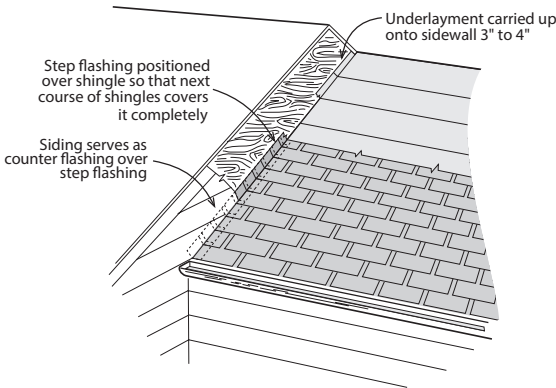

Figure 23

The second course of shingles follows; the end is flashed as in preceding courses and so on to the top of the intersection. Because the metal strip is 7" wide, when the roof shingles are laid with a 5" exposure, each flashing unit will overlap the one on the course below by 2".

Bring wall siding down over the vertical sections of the step flashing to serve as counter flashing. Keep wood siding far enough away from the roof shingles so that it may be painted. (See Figure 23)

Figure 24 Application of Step Flashing Against Vertical Sidewall



Flashing Against Vertical Front Walls

Apply shingles up the roof until a course must be trimmed to fit at the base of the vertical wall. Plan ahead and adjust the exposure slightly in the previous two courses so that the last course is at least 8" wide. Apply a continuous piece of metal flashing over the last course of shingles by embedding it in asphalt roof cement and nailing it to the roof. The metal flashing strip should be bent to extend at least 5" up the vertical wall and at least 4" onto the last shingle course. Do not nail the strip to the wall. Apply an additional row of shingles in asphalt roof cement, (conforming to ASTM D 4586) over the metal flashing strip, trimmed to the width of the strip. (See Figure 24)

Figure 25 Application of Flashing Against Vertical Front Wall

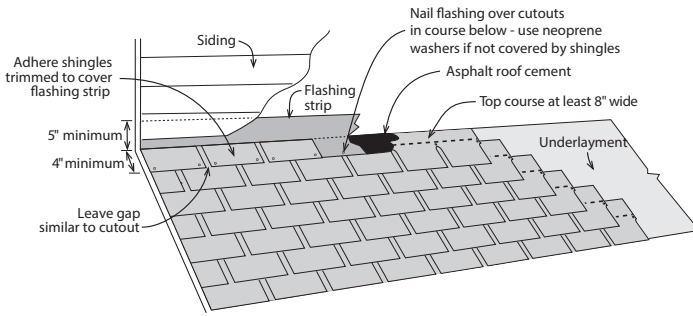

[Caution] Excessive use of asphalt cement may cause blistering.

Bring siding down over the vertical flashing to serve as cap flashing. Keep wood siding far enough away from the roof shingles so that it may be painted. Do not nail siding into the vertical flashing.

If the vertical front wall meets a sidewall, as in dormer construction, cut flashing so that it extends at least 7" around the corner. Then continue up the sidewall with step flashing as described earlier.

FLASHING AROUND CHIMNEYS

To prevent problems that uneven settling can cause, chimneys on older homes were usually built on a separate foundation from that of the main structure. This does not eliminate possible differential settling between the chimney and the main structure. It only frees the chimney from the stresses and distortions that would be imposed on it if both were on the same foundation.

Because of these differential movements, flashings at the point where the chimney projects through the roof calls for a construction that will allow movement without damage to the water seal. To accomplish this, it is necessary to apply apron flashings that are secured to the roof deck and counter flashings that are secured to the masonry. If movement occurs, the counter flashing slides over the apron flashing without affecting water runoff.

NRCA recommends that when a chimney is more than 24" wide a cricket be installed, while the 2003 IRC requires a cricket or saddle be installed on any chimney greater than 30".

Chimneys that project through the roof surface should have a cricket installed at the intersection of the back face of the chimney and the roof deck. The cricket (or wood saddle) is an important element in preserving the integrity of the flashing that will be installed because it prevents the buildup of ice and snow at the rear of the chimney and diverts water runoff around the chimney. (See Figure 26) The cricket should be in place from the start because all roofing materials from the felt underlayment to the roofing shingles are carried over it. If it is not in place, build one as part of the deck preparation prior to applying underlayment and shingles.

Figure 26 Location and Configuration of Chimney Cricket

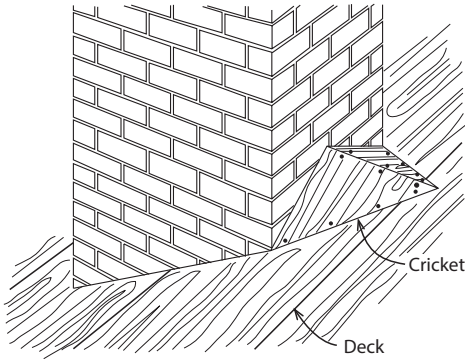

Commonly, a cricket consists of two triangular sections of sheathing supported by appropriate framing members, joined to form a level ridge that extends from the centerline of the chimney back to the roof deck. Nail the sections to the deck and to each other along their meeting edge.

Apply shingles up to the front edge of the chimney before any flashings are installed. In addition, apply a coat of asphaltic masonry primer (conforming to ASTM D 41) to the chimney's brickwork to seal the surface and to provide good adhesion at all points where asphalt roof cement will later be applied.

Begin the flashing construction with the installation of 26-gauge corrosion-resistant metal apron flashing between the chimney and the roof deck on all sides. To provide good adhesion at all points where asphalt roof cement will later be applied.

Figure 27 Pattern for Cutting Front Apron Flashing

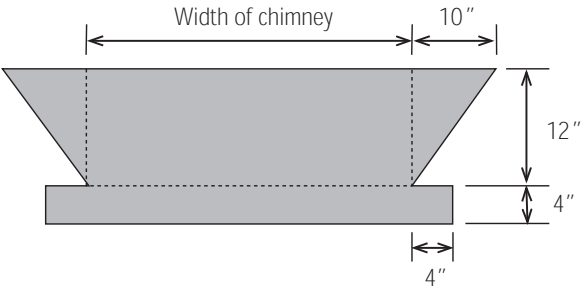

Apply the apron flashing to the front first as shown in Figures 27 and 28. Bend the apron flashing so that the lower section extends at least 4" over the shingles and the upper section extends at least 12" up the vertical face of the chimney. Work the flashing firmly and smoothly into the joint between the shingles and chimney. Set both the roof and chimney overlaps in asphalt roof cement placed over the shingles and on the chimney face. The flashing may be secured against the chimney with one or two nails driven into the mortar joints to hold it in place until the cement sets.

Figure 28 & 29 Application of Apron & Flashing at Front of Chimney

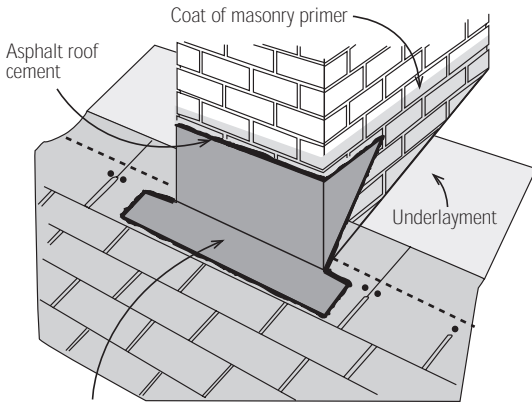

Apron flashing applied over shingles and set in asphalt roof cement

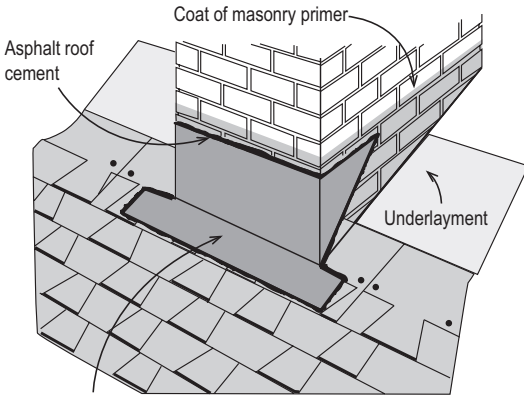

Apron flashing applied over shingles and set in asphalt roof cement

Use metal step flashing for the sides of the chimney, positioning the units in the same manner as flashing a vertical sidewall. Cut, bend and apply the step flashing as shown in Figure 30 Secure each flashing unit to the masonry with asphalt roof cement and to the deck with nails. Embed the end shingles in each course that overlaps the flashing in asphalt roof cement.

Figure 30 Application of Step Flashing at Side of Chimney

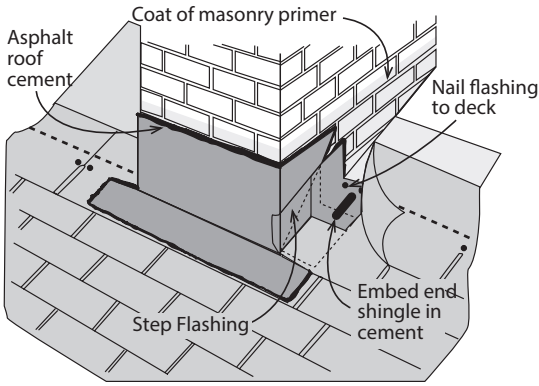

Place the rear cricket flashing over the base and the back of the chimney as shown in Figures 31 through 33 Cut and bend the metal cricket flashing to cover the cricket and extend onto the roof surface at least 6". It should also extend at least 6" up the brickwork and far enough laterally to lap the step flashing on the sides.

Figure 31 Application of corner flashing at rear of chimney

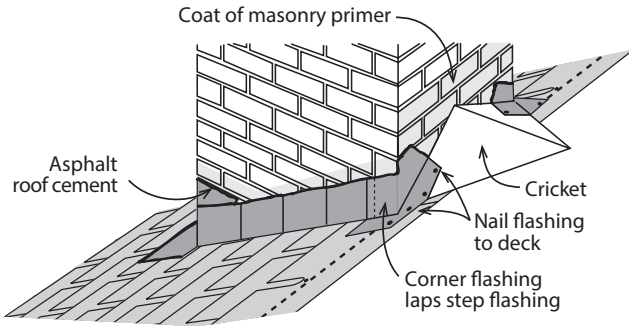
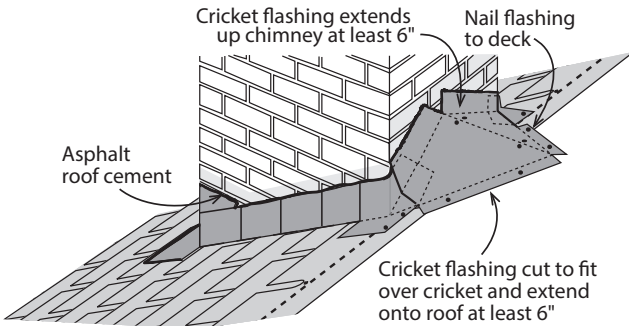
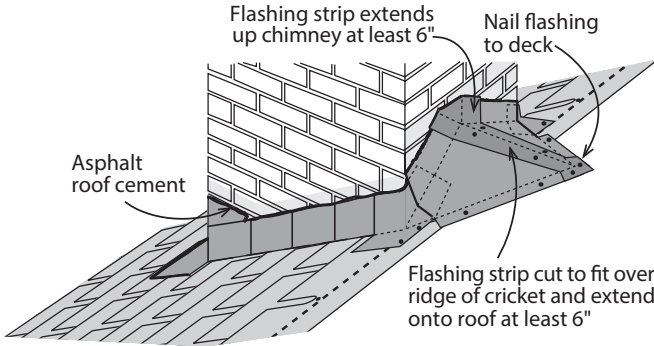

Figure 32 Application of Flashing Over Cricket



If large enough, the base may be covered with shingles. Otherwise, apply the rear apron flashing, bring the end shingles in each course up to the cricket and cement them in place.

Figure 33 Application of Flashing Over Ridge of Cricket



Counter flashings must now be placed over all apron, cricket and step flashings for positive exclusion of water from the joint. Begin by setting the metal counter flashing into the brickwork as shown in Figure 34. This is done by raking out a mortar joint to a depth of 1 1/2" and inserting the bent edge of the flashing into the cleared joint. Once in place and being under a slight amount of spring tension, the flashing cannot be dislodged easily. Refill the joint with Portland cement mortar. Finally, bend the flashing down to cover the flashing and to lie snugly against the masonry.

Figure 34 Application of Counter Flashing

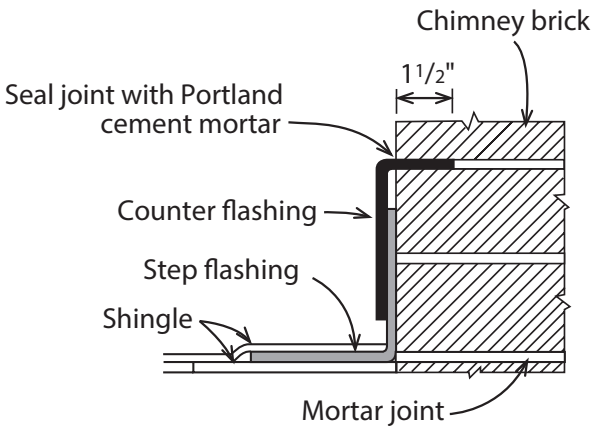

Use one continuous piece of counter flashing on the front of the chimney as shown in Figure 35. On the sides and back of the chimney, use several pieces of similar-sized flashing, trimming each to fit the particular location of brick joint and roof pitch. (See Figure 36)

Start the side units at the lowest point and overlap each at least 3". As this is a metal cricket, it should be left un-shingled in case a leak occurs (a leak would not be readily detectable if the cricket were shingled).

Figure 35 Application of Counter Flashing at Front & Side of Chimney

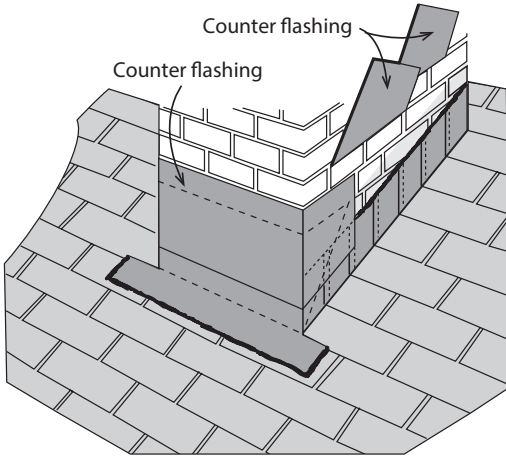

Figures 36 Application of Counter Flashing at Side & Rear of Chimney

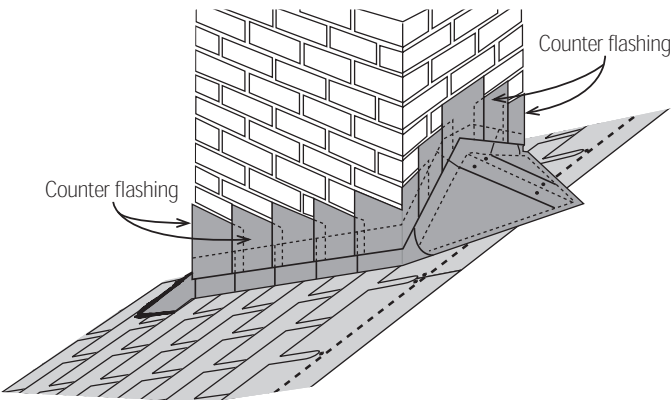

Figures 37 Application of Counter Flashing at Side & Rear of Chimney

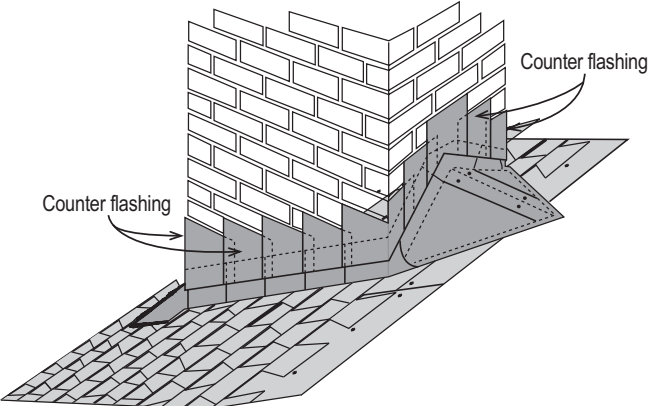

Roofing Ventilation



International Residential Code (IRC)

- Minimum 1 sq. foot NFVA per 150 sq. feet attic floor (1:150 ratio)
- You can reduce ventilation in half (1:300 ratio) under the following conditions:
 - Vapor retarder with a perm of 1 or less OR
 - 50% of required vent area located at the upper portion (at least 3 feet above eave) balance at eave

Determine the Square Footage of the Attic or Area to be Vented (To do this, multiply the width in feet by the length in feet)

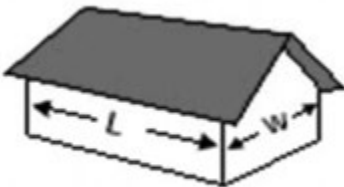

Square Feet

PROPER VENTILATION: INTAKE LOW – EXHAUST HIGH

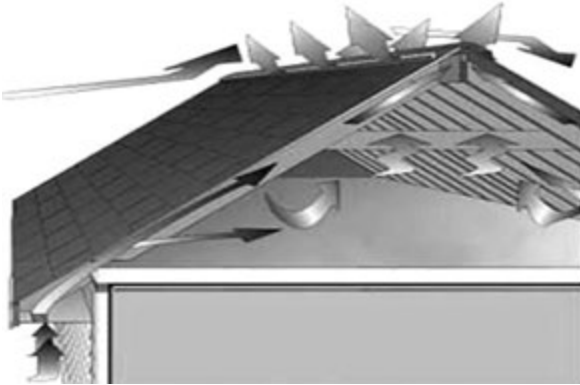

No Ventilation

Traps moisture and heat

Higher energy bills and mold

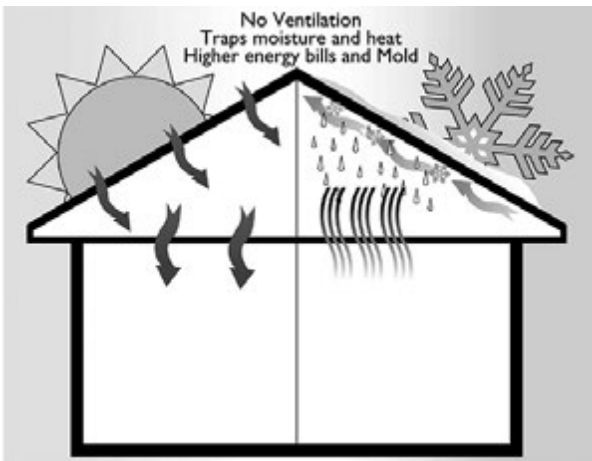

Ventilation

Removes Heat & Moisture

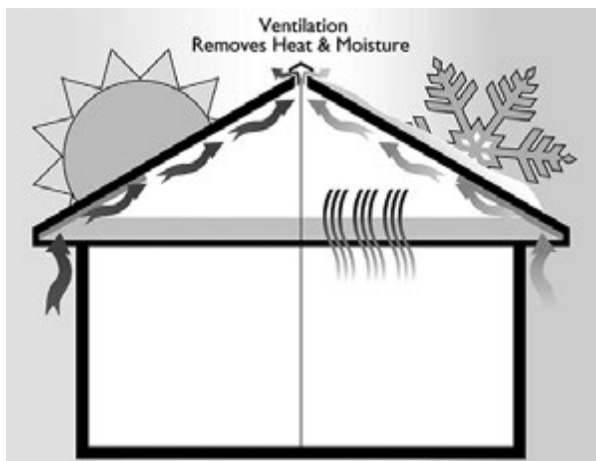

Mold in the Attic

Lack of ventilation



Mold in the Attic

No ventilation or blocked intake - note the frost on the tips of the nails



If a continuous exhaust vent and an equal or slightly greater amount of intake vent is installed, then the attic will be ventilated for its entire length.

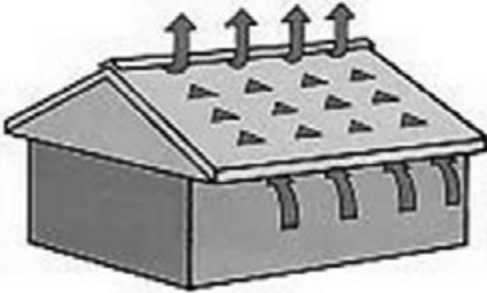

This picture shows what happens if you have no intake vents along the eaves. Air will circulate only between the exhaust vents leaving the remainder of the attic space unventilated.

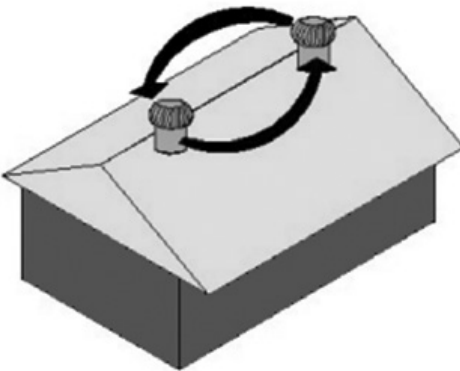

Summary

Your roof protects one of the largest investments you'll ever have, as well as your belongings. It can enhance your home's curb appeal and may also increase its resale value. Most importantly, the roof protects you and your family. So you want to be sure it will last a long time. Remember, if you have any questions about your roof, Owens Corning is always here to help. You can contact us at 1-800-GET-PINK® or through our website at www.owenscorning.com.

Roofing Failures

- Lets look at some example of improper flashing details and workmanship.

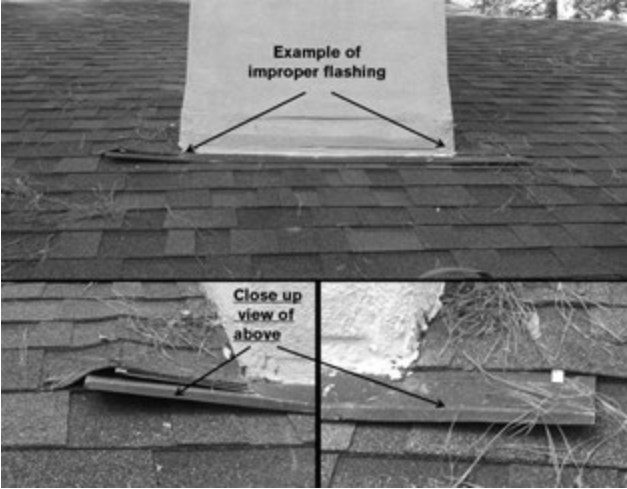

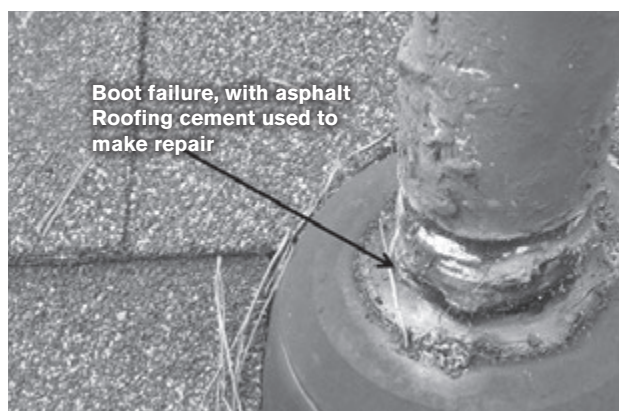
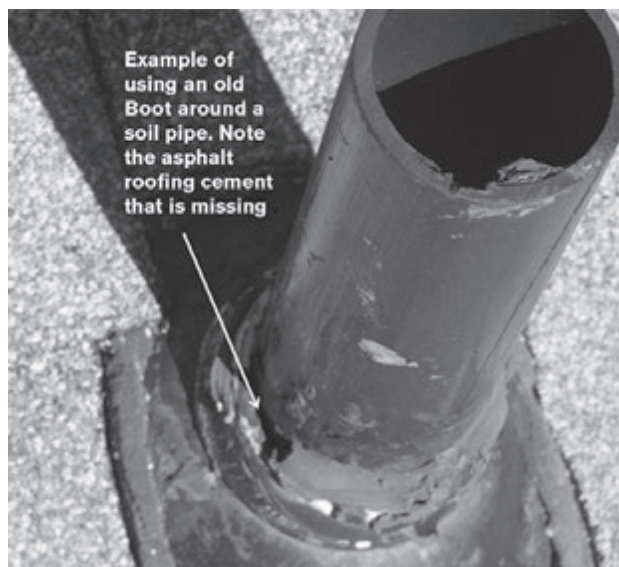

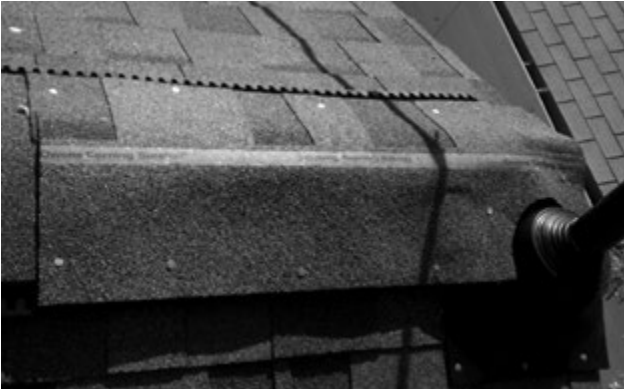

Ridge Vent with pipe coming through the top and then a shingle used for the ridge cap



Blocked Intake

Notice how mold is starting to grow on the underside of the roof deck



Vent Pipe

The vent pipe is disconnected in the attic allowing moist air to be exhausted in the attic area

Estimating How Much Roofing is Required

Various types of asphalt roofing materials and accessories are required to complete a typical roofing job including shingles or roll roofing, underlayment, starter strips, drip edges, valley flashings and hip and ridge shingles. Before the job begins, estimates of the required quantities of each material, based on calculations derived from the dimensions of the roof, must be made.

Fairly simple calculations are all that are required. Certain measurement and calculation methods also may be used that simplify the process even further. These are described in the following sections along with suggestions on how to take measurements.

Note: The most accurate method to measure a roof is from up on the roof. Taking these measurements should be done by a roofing professional. It is not recommended that homeowners climb up on a roof to take these measurements. If a homeowner wants to estimate the size of their roof from the ground there are various resources available on the Internet that can provide assistance.

Estimating Area (Simple Roofs)

Roofs come in a variety of shapes and styles but virtually every kind of roof is comprised of plane surfaces that can be subdivided into simple geometric shapes — squares, rectangles, trapezoids and triangles. Thus, roofing area calculations simplify to area calculations for these basic shapes.

The simplest type of roof is one without any projecting dormers or intersecting wings. Each of the illustrated roofs is comprised of one or more rectangles. (See Figure 38) The area of the entire roof in each case is the sum of the areas of each rectangle.

Figure 38 Examples of simple roofs

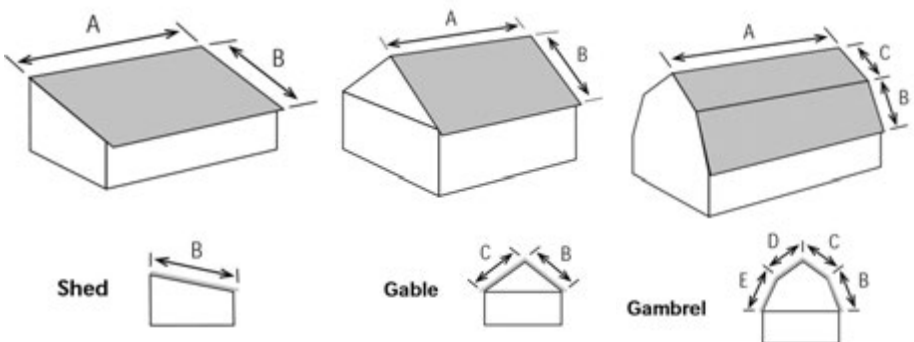

For the shed roof which has only one rectangle, the area is found by simply multiplying the rake line by the eaves line, or $B \times A$. The gable roof is comprised

of two rectangular planes and its area is found by multiplying the sum of the rake lines by the eave line, or $A(B + C)$. For the gambrel roof, four rake lines are involved and the total area calculation is found by multiplying the sum of the rake lines by the eave line, or $A(B + C + D + E)$.

Estimating Area (Complex Roofs)

The more complex roofs include those with intersecting wings or dormer projections through the various roof planes. Area calculations for these roofs use the same basic approach taken for simple roofs but involve a number of subdivisions of the roof surface that are calculated separately, then added together to obtain the total roof area.

If plans of the building are available, use them to obtain the required roof dimensions from which area calculations can be made. Otherwise, direct measurements may have to be taken on the roof.

There are many ways in which to calculate the area of a roof. This section will demonstrate one method of how to do it properly. The final answer will be in "squares", the unit of area measurement used in roofing.

$$1 \text{ square} = 100 \text{ square feet}$$

Some simple geometry is required to use this method.

The base length (b) times the height (h) of any triangle is twice its area (A). So if you divide the product of the base and height by two, then you have the area of a triangle.

$$(b \times h) / 2 = \text{Area of a triangle}$$

Although the following two triangles, R and H, look different from each other, they in fact have exactly the same area.

$$(20' \times 20') / 2 = 200 \text{ square feet}$$

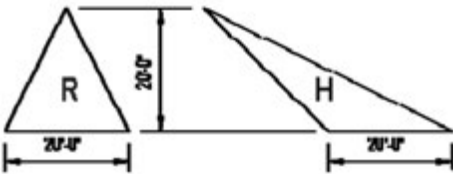

The picture below represents an aerial view of a roof with one hip end and three gable ends. It is strongly recommended that you make a rough sketch of your roof. In order to make it easier for measuring, the roof sketch has been broken up into sections A through F. These sections show the plan view (top looking down) shown in a flat layout even though the roof is not flat.

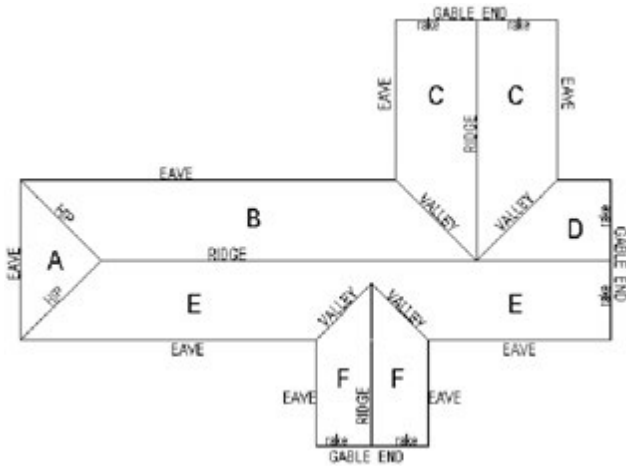

Section A

Section A is a simple triangle. Measure the length of the eave and the perpendicular line from the eave to the peak. Multiply these numbers and divide the answer by two.

$$(30' \times 15')/2 = 225 \text{ square feet}$$

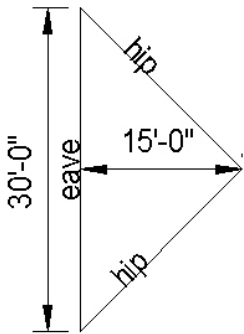

So **Section A** has 225 square feet in it.

Section B

Measure this section by dividing it up into three different sections: x, y, and z. Sections x and z appear to be the same size. However it is a good idea to measure both triangles.

$$x = (15' \times 15')/2 = 112.5 \text{ square feet}$$

$$y = 55' \times 15' = 825 \text{ square feet}$$

Add another 112.5 square feet to our current list of numbers, since z has been determined to be equal to x after measuring.

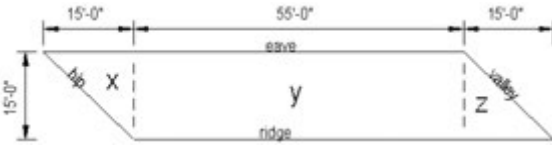

So **Section B** has a total of $112.5 + 112.5 + 825 = 1,050$ square feet.

Section C

As with **section B**, **section C** appears to have symmetrical sides. Divide it up into sections. A quick measurement verifies that x and z are the same as w and y , therefore multiply the sum of w and y by 2 for the final Area.

$$w = 30' \times 15' = 450 \text{ square feet}$$

$$y = (15' \times 15')/2 = 112.5 \text{ square feet}$$

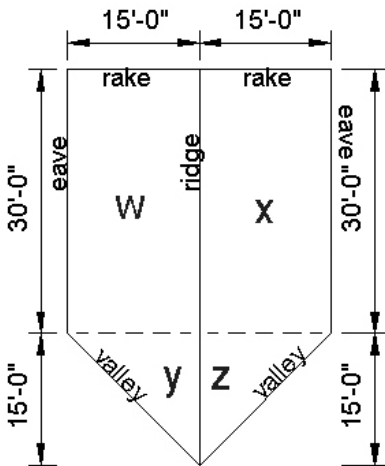

Section C = $(450 + 112.5) \times 2 = 1,125$ square feet.

Section D

$$x = (15' \times 15')/2 = 112.5 \text{ square feet}$$

$$y = 10' \times 15' = 150 \text{ square feet}$$

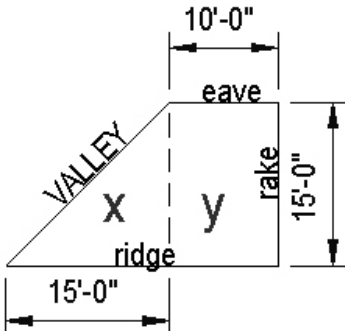

Section D = $112.5 + 150 = 262.5$ square feet

Section E

Because this section has several different subsections, it is important to double check the measurements in the sketch and to make sure that every piece is either rectangular or triangular.

$$s = (15' \times 15')/2 = 112.5 \text{ square feet}$$

$$t = 40' \times 15' = 600 \text{ square feet}$$

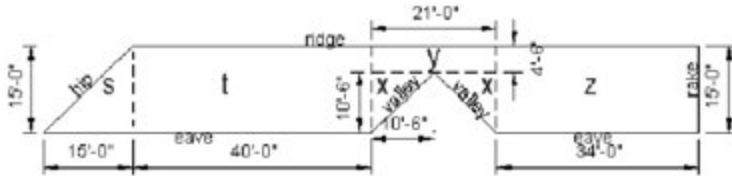

Both small triangles in the center part should be checked to make sure that they are the same size.

$$x = (10.5' \times 10.5')/2 = 55 \text{ square feet}$$

$$y = 21' \times 4.5' = 94.5 \text{ square feet}$$

The actual answer of x is $55\frac{1}{2}$ square feet, but it has been rounded off for ease of measuring.

$$z = 34' \times 15' = 510 \text{ square feet}$$

Section E = $112.5 + 600 + 55 + 55 + 94.5 + 510 = 1,427$ square feet.

Section F

This section is a smaller version of **Section C** and should be calculated the same way.

$$w = (10.5' \times 10.5')/2 = 55 \text{ square feet}$$

$$y = 20' \times 10.5' = 210 \text{ square feet}$$

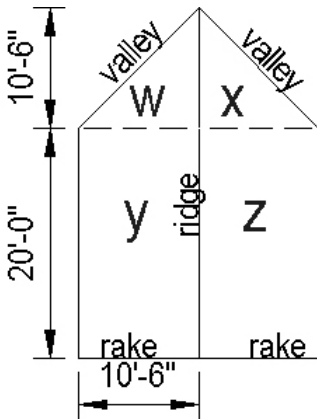

Section F = $55 + 55 + 210 + 210 = 530$ square feet.

Sum It Up

Adding up the subtotals from all sections:

Section A	= 225
Section B	= 1,050
Section C	= 1,125
Section D	= 262.5
Section E	= 1427
Section F	= 530

Total square footage is equal to 4,619.5 square feet, or roughly 46 squares, since:

$$1 \text{ square} = 100 \text{ square feet}$$

The application of roofing requires trimming of shingles in valleys, roof penetrations and rake edges. Once the roof area is determined the amount of shingle material will need to be adjusted for the trimming. The increase in the amount needed to complete the roofing project will vary depending on the roof complexity. In most cases it should be between 2% and 10%.

A Roof Pitch and Slope

Determining Your Roof's Slope

The slope of your roof is determined by the vertical rise in inches for every horizontal twelve- inch (12") length (called the "run"). It is expressed with the rise mentioned first and the run mentioned second. For instance, if your roof has a four inch (4") rise for every horizontal foot, then it is said to have a "4 in 12" slope.

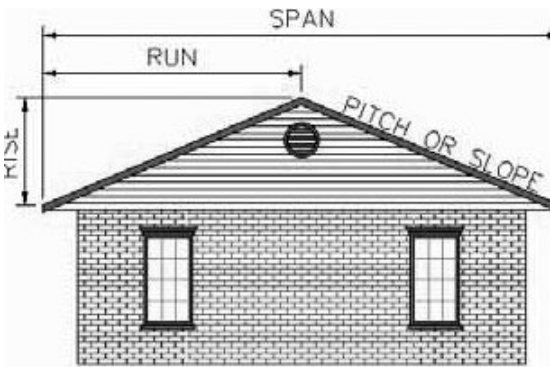

A fairly easy way to determine the slope is to use a 12" carpenter's level. Set one end on the roof surface and level the carpenter's level. Using a tape measure or a ruler, measure from the other

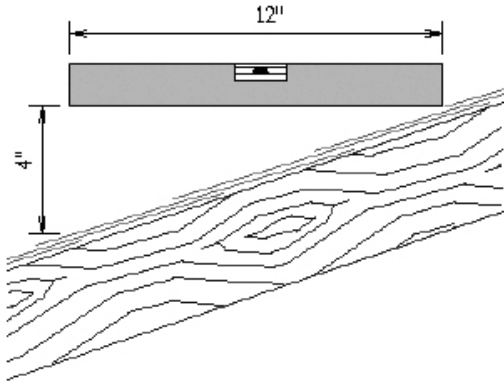

Additional Material Estimates

To complete the estimate, the required quantity of starter strips, drip edges, hip and ridge shingles and valley strips must be determined. Each of these estimates depends on the length of the eave, rakes, hips, ridges and valleys at which the material will be applied.

Most roofing jobs require anywhere from 2% to 10% excess shingles due to trim waste. The amount of trim waste depends on how many valleys, dormers, hips and roof penetrations.

Note: The drawings and some of the descriptions found in “Estimating Area (Complex Roofs)” have been used courtesy of E. J. Sandquist, www.roofhelp.com.

Berkshire® Collection

Application Instructions

Before installing this product, check local building codes for their roofing requirements. These laminated shingles are designed for new or reroofing work over any properly built and supported wood roof deck having adequate nail-holding capacity and a smooth surface. Check local building codes regarding deck load limits. Because Owens Corning® Berkshire® shingles are 360 avg. wt./sq., it must be determined if the roof frame can support workers and the weight of the shingles. It may not be feasible to apply the product over an existing shingle roof.

Precautionary Note:

The manufacturer will not be responsible for problems resulting from any deviation from the recommended application instructions and the following precautions:

Roof Top Loading: Lay shingle bundles flat. Do not bend over the ridge.

Roof Deck: ▪ 6" Minimum roof deck boards ▪ Minimum $\frac{3}{8}$ " plywood ▪ Minimum $\frac{7}{16}$ " OSB

Regardless of deck type used, the roofing installer must:

1. Install the deck material in strict compliance with the deck manufacturer's instructions.
2. Prevent the deck from getting wet before, during and after installation.

Ventilation: Must meet local building codes.

Handling: Use extra care in handling shingles when the temperature is below 40°F.

Storage: Do not stack more than two pallets high. Store in a covered, ventilated area at a maximum temperature of 110°F.

Nails must be corrosion-resistant,

11- or 12-gauge, with heads at least $\frac{3}{8}$ " in diameter. **Staples** must be 16-gauge minimum, $\frac{15}{16}$ " minimum crown width and sufficient length to penetrate $\frac{3}{4}$ " into wood decking or through APA-rated roof sheathing. Staples are to be corrosion protected.

All Fasteners must penetrate at least $\frac{3}{4}$ " into the wood deck or completely through plywood sheathing.

Properly Driven **Improperly Driven**
Correctamente colocado **Incorrectamente colocado**

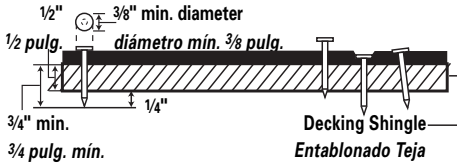

Notice: Owens Corning recommends the use of nails as the preferred method of attaching shingles to wood decking or other nailable surfaces.

1. Specialty Eave Flashing:

WeatherLock® Underlayment or equivalent eave and flashing membrane applied to a point at least 24" beyond interior wall line. See manufacturer's installation instructions. See Fig. 1.

Fig. 1 Specialty Eave Flashing
Revestimiento especial para alero

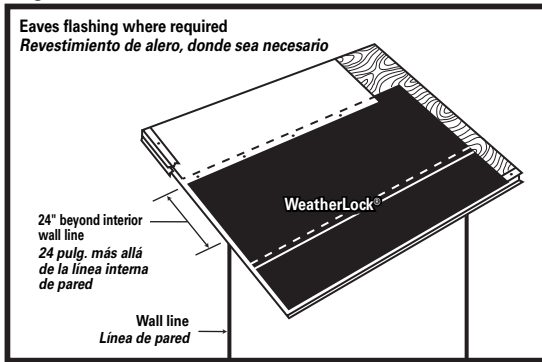

2. Underlayment:

Standard Slope (4" in 12" or more) Application of underlayment, metal drip edges, and eaves flashing: See Fig. 2.

Low Slope (2" in 12" to less than 4" in 12")

Application of underlayment and metal drip edges: See Fig. 2A.

Fig. 2 Underlayment Standard Slope
Capa inferior con pendiente estándar

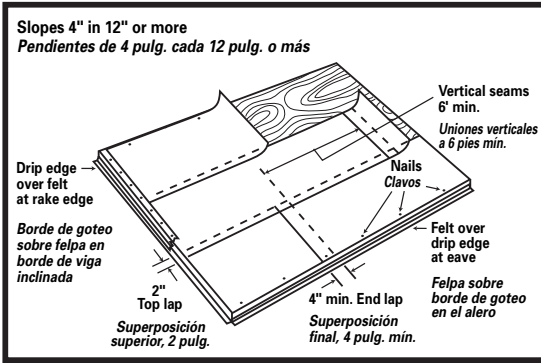
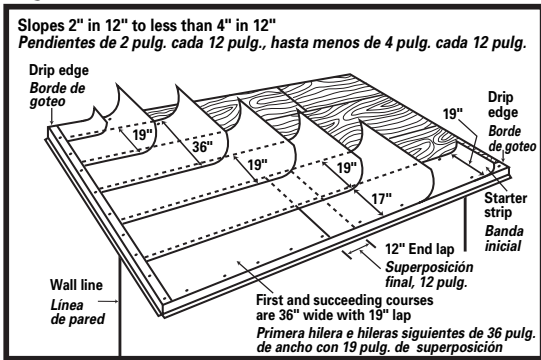

Fig. 2A Underlayment Low Slope
Capa inferior con pendiente baja



3. Chalk Lines:

To aid in shingle alignment, it is recommended that chalk lines be snapped on the exposed surface of the underlayment prior to shingle application. See Fig. 3.

Fig. 3 Chalk Lines
Líneas de tiza

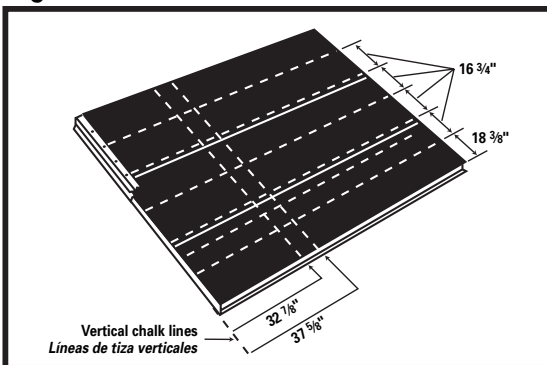

4. Starter Course:

Use *Berkshire* Shingles. Apply per *Fig. 4*.

Caution: Using shingle products other than *Berkshire* for the starter course may result in a color variation at the lower edge of the roof.

Fig. 4 Starter Course
Hilera inicial

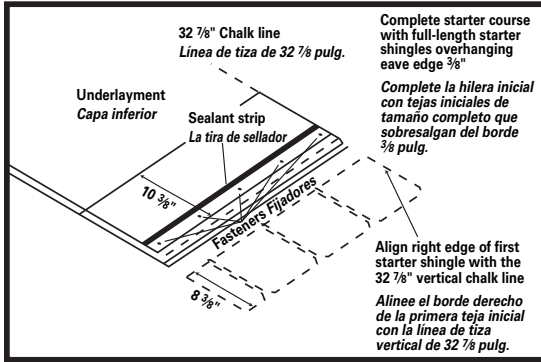

5. Shingle Fastening:

Standard Fastening Pattern. See *Fig. 5*.

Place fasteners 5/8" above the tab cutout and below the lower edge of the sealant strip. Fastening into the sealant strip interferes with sealing and contributes to blow-offs.

Note: Do not drive fasteners into or above the adhesive strip.

Mansard or Steep Slope Fastening Pattern. See *Fig. 5A*.

REQUIRED: For slopes exceeding 60 degrees or 21 inches per foot, use six fasteners and four spots of asphalt plastic cement per shingle. Apply immediately; one 1" diameter spot of asphalt plastic cement **under** each shingle tab. Center asphalt plastic cement 2" up from bottom edge of shingle tab. See *Fig. 5A*.

Plastic Cement where required must meet ASTM D4586 Type I or II (Asbestos Free).

Fig. 5 Standard Fastening Pattern
Esquema de fijación estándar

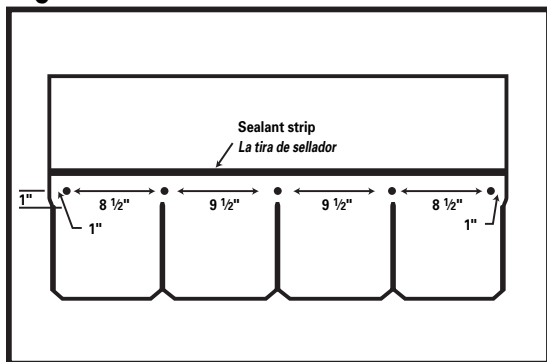
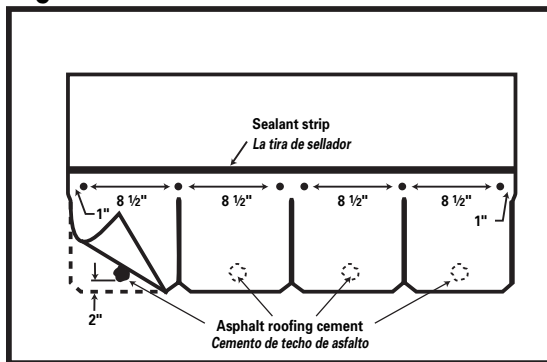

Fig. 5A Mansard or Steep Slope Fastening Pattern
Esquema de fijación para mansardas o pendientes agudas



6. Course Application:

Vertical Racking Method. Apply shingles over properly prepared roof deck, starting at bottom of roof using the single-column, vertical-racking method. Owens Corning *Berkshire* shingles **must** be applied with a 4-³/₄" offset and 8³/₈" exposure. Caution must be exercised to ensure that end joints are no closer than 2" from a fastener in the shingle below. Refer to course application steps for specific instructions.

Note: Owens Corning *Berkshire* shingles ARE NOT to be installed across and diagonally up the roof.

First Course:

Apply first course starting with a full shingle, even with the lower edge of the starter course shingle, align the right edge of the shingle with the 37⁵/₈" vertical line. Align the top edge of the shingle with the 18³/₈" horizontal chalk line. See *Fig. 6*.

Second Course:

Align the right edge of the first shingle of the second course with the $32\frac{7}{8}$ " vertical chalk line. Align bottom edge of the shingle with the top of the shingle cutouts in the first course, leaving $8\frac{3}{8}$ " exposure. Fasten securely and trim $4\frac{3}{4}$ " excess overhang at rake, leaving $\frac{3}{8}$ " overhang. See Fig. 6A.

Succeeding Courses:

Alternate shingle courses. Odd- numbered courses start with a full shingle aligned with the $37\frac{5}{8}$ " vertical chalk line and the top edge aligned with the horizontal chalk line, leaving $8\frac{3}{8}$ " exposure. Even-numbered courses will start with the right edge of the shingle aligned with the $32\frac{7}{8}$ " vertical chalk line. Shingles are applied up the rake in a single-column racking fashion. See Fig. 6B.

Fig. 6 Shingle Application
Aplicación de tejas

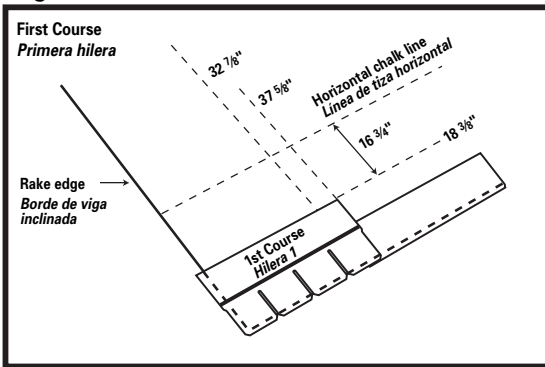

Fig. 6A Shingle Application
Aplicación de tejas

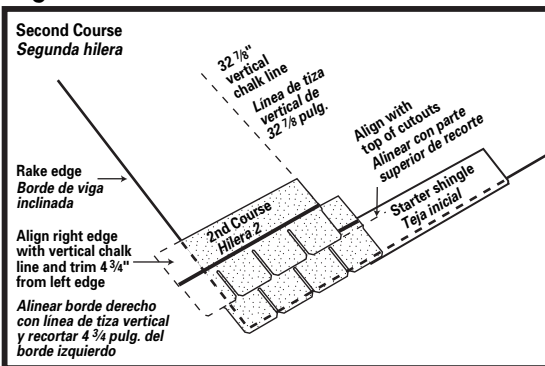
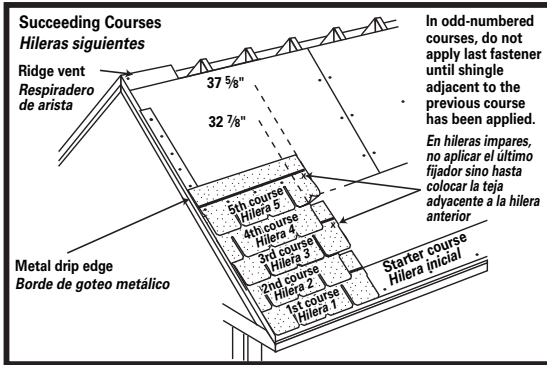

Fig. 6B Shingle Application
Aplicación de tejas



Fasten each **full** shingle in the odd-numbered courses with **four (4)** fasteners. **DO NOT** fasten the right edge of the full shingles in the odd-numbered courses at this time as the shingle being installed adjacent to the previous course will have to be positioned beneath the right edge of this full shingle. When the shingle adjacent to the previous course has been positioned, apply five (5) fasteners in that shingle (even-numbered courses) and apply one fastener to the unfastened end of the shingle above.

Fasten the shingles in the even-numbered (where the first shingle in the course is aligned with the $32 \frac{7}{8}''$ chalk line) courses using five (5) fasteners. See Fig. 6B.

Work up the roof starting at the eave edge one column at a time following the above procedure. Butt full shingles against the right edge of the shingles that have been applied in each course, again working one column at a time until the courses have been completed.

7. Open Valley Construction:

Woven and closed-cut valleys are not recommended for Owens Corning Berkshire shingles.

Lay a 36"-wide valley liner of Owens Corning® WeatherLock® underlayment or equivalent. A 36"-wide minimum #50 smooth surface roll roofing can also be used as a valley liner. Fasten on outer edges only a minimum of 6" away from center-line on each side of valley. See Fig. 7.

Recommended valley flashing is 24"-wide 26-gauge galvanized metal or an equivalent corrosion-resistant, nonstaining material. Secure the valley metal to the roof deck with fasteners spaced 8"-12" apart. Overlaps should be 12" and cemented. See Fig. 7.

Snap a chalk line on each side of the valley centerline over the full length of the valley flashing. Space the chalk lines 6" apart at the ridge (3" to either side of the valley centerline). The lower ends of the chalk lines should

diverge from each other $\frac{1}{8}$ " per foot (i.e., for an 8' valley the chalk lines will be 7" apart at the eaves). See Fig. 7A.

As the shingles are applied toward the valley, the last shingle in each course will be trimmed to fit on the chalk line.

Note: Do not use a shingle less than 12" in length to finish a course running into a valley.

If necessary, trim a tab off the adjacent shingle in the course to allow a longer portion to be used.

Clip 1" from the upper portion of the shingle on a 45° angle to divert water into the valley. See Fig. 7A.

Cement the shingle to the valley lining with a 3"-wide band of asphalt plastic cement conforming to ASTM D 4586, Type I or II. See Fig. 7A.

Fig. 7 Open Valley Construction
Construcción con canal descubierto

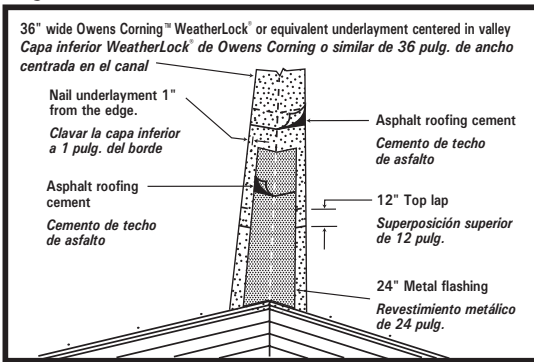
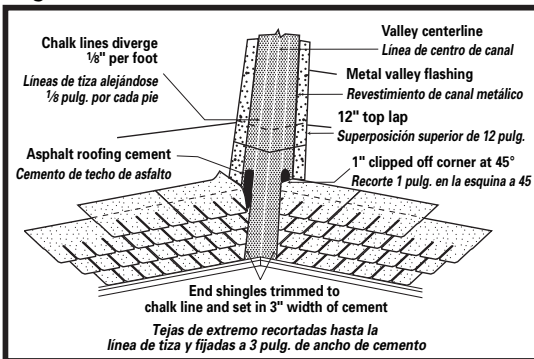

Fig. 7A Open Valley Construction
Construcción con canal descubierto



8. Step Flashing:

Use 10" x 12" corrosion-resistant metal where roof planes butt against vertical sidewalls or chimneys. See Fig. 8.

Fig. 8 Step Flashing
Revestimiento escalonado

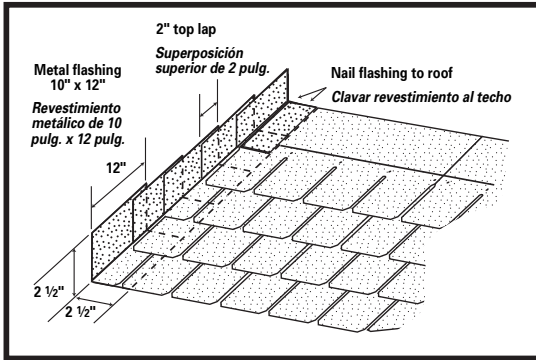

9. Hip & Ridge Application:

Use *Berkshire* Hip and Ridge Shingles.

Follow application instructions as printed on the Berkshire Hip & Ridge carton.

Woodmoor® & Woodcrest® Shingles

Application Instructions:

Before installing this product, check local building codes for their roofing requirements.

These laminated shingles are designed for new or reroofing work over any properly built and supported wood roof deck having adequate nail holding capacity and a smooth surface. Check local building codes regarding deck load limits. Because Owens Corning® Woodcrest®/Woodmoor® shingles are 360/465 avg. wt./sq., it must be determined if the roof frame can support workers and the weight of the shingles. It may not be feasible to apply the product over an existing shingle roof.

Precautionary Note:

The manufacturer will not be responsible for problems resulting from any deviation from the recommended application instructions and the following precautions:

Roof Top Loading: Lay shingle bundles flat. Do not bend over the ridge.

Roof Deck: ▪ 6" Minimum roof deck boards ▪ Minimum 3/8" plywood ▪ Minimum 7/16" OSB

Regardless of deck type used, the roofing installer must:

1. Install the deck material in strict compliance with the deck manufacturer's instructions.
2. Prevent the deck from getting wet before, during and after installation.

Ventilation: Must meet local building codes.

Handling: Use extra care in handling shingles when the temperature is below 40°F.

Storage: Store in a covered ventilated area at a maximum temperature of 110°F. Stack in a flat fashion (maximum of 10 bundles high). Protect shingles from weather when stored at the job site. Do not store near steam pipes, radiators, etc.

Nails must be corrosion-resistant, 11- or 12-gauge, with heads at least 3/8" in diameter. Staples must be 16-gauge minimum, 15/16" minimum crown width and sufficient length to penetrate 3/4" into wood decking or through APA-rated roof sheathing. Staples are to be corrosion protected.

All Fasteners must penetrate at least 3/4" into the wood deck or completely through plywood sheathing.

Notice: Owens Corning recommends the use of nails as the preferred method of attaching shingles to wood decking or other nailable surface.

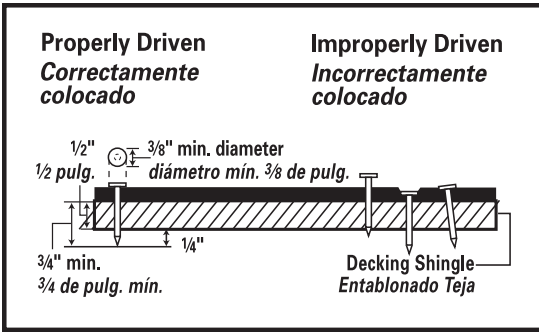

1. Specialty Eave Flashing:

WeatherLock® underlayment or equivalent eave and flashing membrane applied to a point at least 24" beyond interior wall line. See manufacturer's installation instructions. See Fig. 1.

Fig. 1 Specialty Eave Flashing
Revestimiento especial para alero

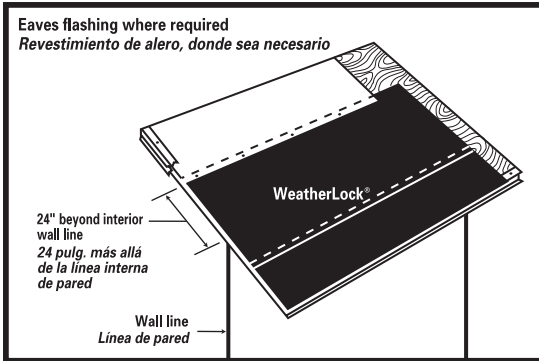

2. Underlayment:

Standard Slope (4" in 12" or more): Application of underlayment, metal drip edges, and eaves flashing: See Fig. 2.

Low Slope (2" in 12" to less than 4" in 12"): Application of underlayment and metal drip edges: See Fig. 2A.

Fig. 2 Underlayment Standard Slope
Capa inferior con pendiente estándar

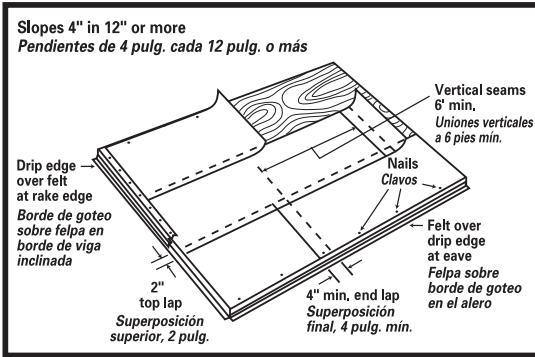
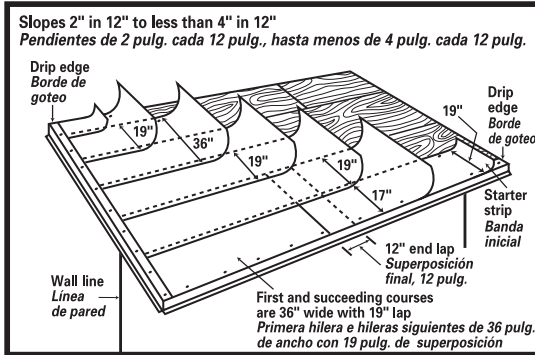

Fig. 2A Underlayment Low Slope
Capa inferior con pendiente baja



3. Starter Course:

Left Rake Application: Cut 35" off from the first bottom starter piece. Fasten the remaining 5" x 13³/₈" to the deck as shown in Fig. 3, followed by a full 13³/₈" x 40" starter piece to the deck with 5 fasteners as shown.

Right Rake Application: Cut 5" off from the first bottom starter piece. Fasten the remaining 35" x 13³/₈" to the deck as shown in Fig. 3, followed by a full 13³/₈" x 40" starter piece to the deck with 5 fasteners as shown.

Caution: Using shingle products other than WoodStart® Starter Strip for the starter course may result in a color variation at the lower edge of the roof.

Fig. 3 Starter Course
Hilera inicial

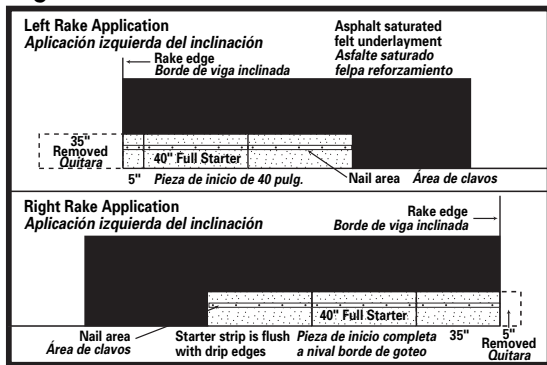

**4. Shingle Fastening:
 Standard Fastening Pattern:**

Place fasteners in nail area. See Fig. 4.

Fig. 4 Standard Fastening Pattern
Esquema de fijación estándar

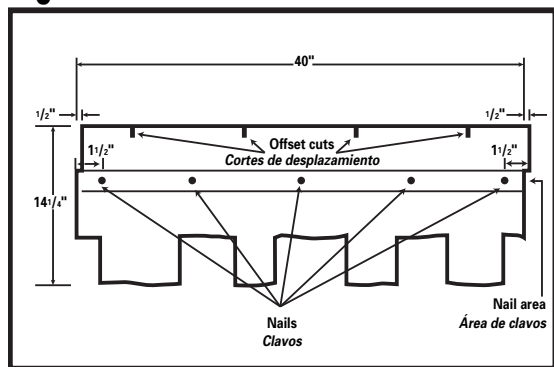

5. Mansard or Steep Slope Fastening Pattern: See Fig. 5.

REQUIRED: For slopes exceeding 60 degrees or 21 inches per foot, 9 nails are required with 5 in the nail area and 4 placed above tab cutouts.

1. Position the first course shingle applying 5 nails in the nail area.
2. Temporarily position the second course shingle above to determine the location for the additional 4 fasteners.
3. Once you have added the additional fasteners in the tab area, apply 4 spots of asphalt cement under each tab and press in place.
4. Apply all succeeding shingle courses in the same manner.

Note: Too much roofing cement can cause shingles to blister.
Plastic Cement where required must meet ASTM D4586, Type I or II (Asbestos Free).

Fig. 5 Mansard or Steep Slope Fastening Pattern
 Esquema de fijación para mansardas o pendientes agudas

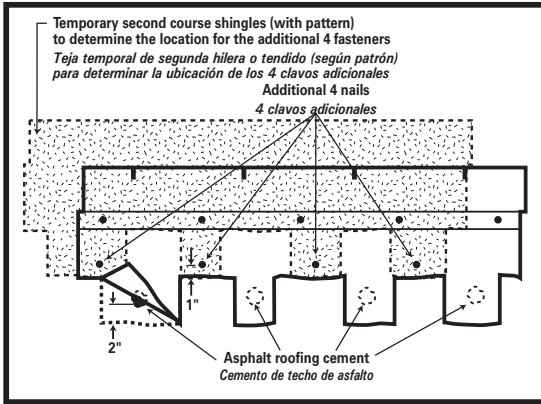

6. Measurement Area:

When aligning for offset pattern, measure from area A or area B.
 See Fig. 6.

Fig. 6 Measurement Area
 Área de medida

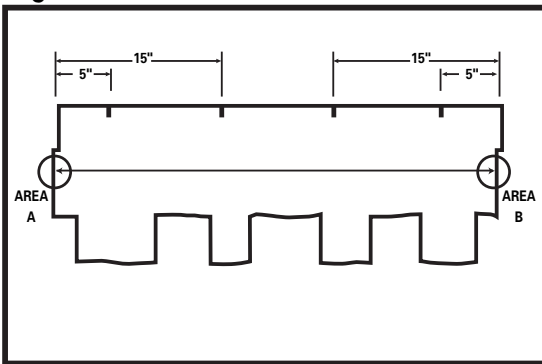

7. 5" & 5" Course Application:

Owens Corning® Woodcrest®/Woodmoor® shingles can be applied with a **5" & 5" OR 5" & 15"** offset, (See Fig. 4) with 4" exposure. Shingles can be installed from either **left** or **right** rake edge.

First Course: Start with a full shingle even with the lower edge of the starter course shingle. See Fig. 7.

Fig. 7 Shingle Application 5" & 5" offset pattern
 Aplicación de tejas en patrón de desplazamiento de 5 pulg. y 5 pulg.

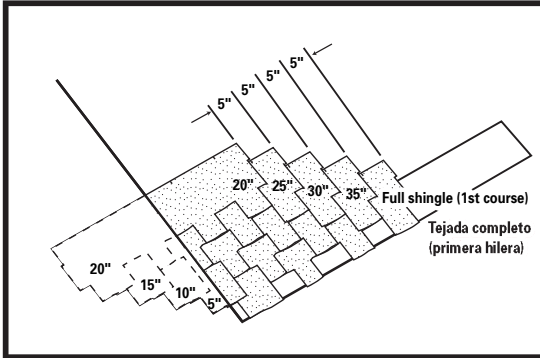

8. 5" & 15" Course Application:

Owens Corning® Woodcrest®/Woodmoor® shingles can be applied with a **5" & 5" OR 5" & 15"** offset, (See Fig. 4) with 4" exposure. Shingles can be installed from either **left** or **right** rake edge.

First Course: Start with a full shingle even with the lower edge of the starter course shingle. See Fig. 8.

Second Course: Cut 5" from a full shingle. Install the remaining 35" piece using the alignment notch on the shingle. See Fig. 8A.

Third Course: Cut 20" from a full shingle. Install the remaining 20" piece using the alignment notch on the shingle. See Fig. 8B.

Fourth Course: Cut 25" from the edge of the fourth course full shingle. Install the remaining 15" piece using the alignment notch on the shingle. See Fig. 8C.

Succeeding Courses: For succeeding courses, repeat first through fourth course. See Fig. 8D.

Fig. 8 Shingle Application 5" & 15" offset pattern
 Aplicación de tejas en patrón de desplazamiento de 5 pulg. y 15 pulg.

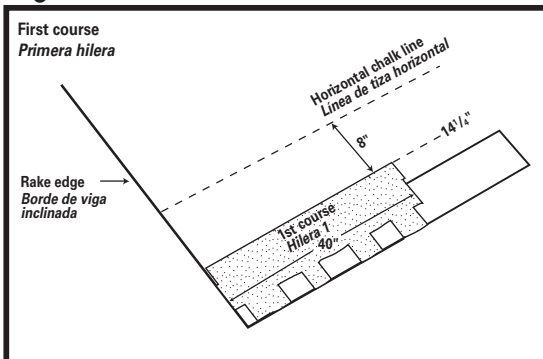

Fig. 8A Shingle Application 5" & 15" offset pattern
 Aplicación de tejas en patrón de desplazamiento de 5 pulg. y 15 pulg.

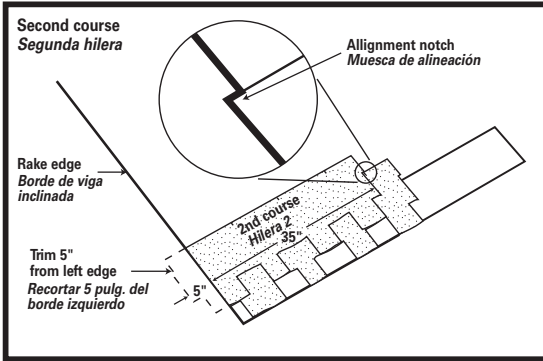

Fig. 8B Shingle Application 5" & 15" offset pattern
 Aplicación de tejas en patrón de desplazamiento de 5 pulg. y 15 pulg.

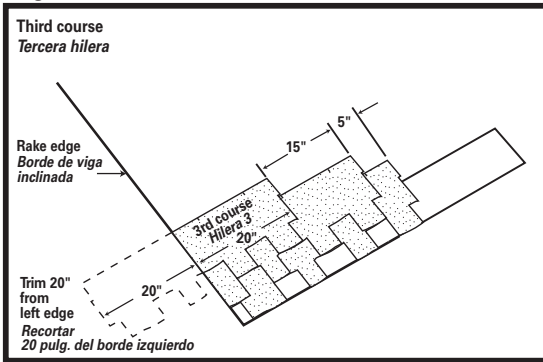

Fig. 8C Shingle Application 5" & 15" offset pattern
 Aplicación de tejas en patrón de desplazamiento de 5 pulg. y 15 pulg.

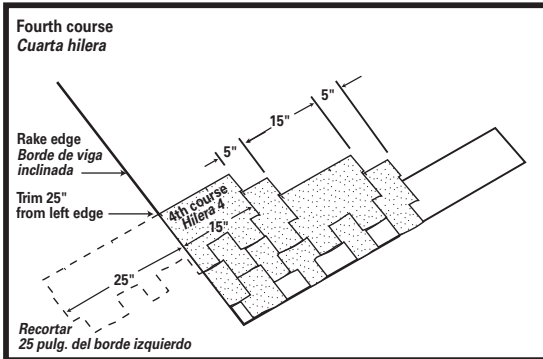
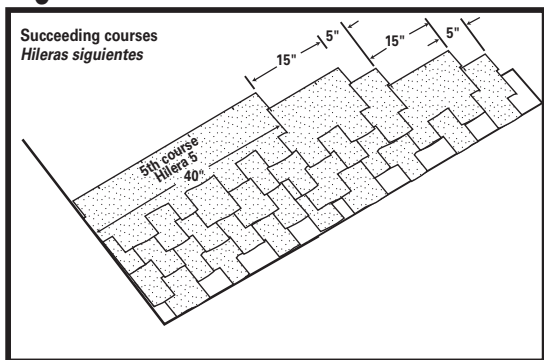

Fig. 8D Shingle Application Aplicación de tejas



9. Valley Construction: Open Valley

Lay a 36" wide valley liner of Owens Corning® WeatherLock® underlayment or equivalent. A 36" wide minimum 50-lb. smooth surface roll roofing can also be used as a valley liner. Fasten on outer edges only a minimum of 6" away from centerline on each side of valley. See Fig. 9.

Recommended valley flashing is 24" wide 26-gauge galvanized metal or an equivalent corrosion-resistant, nonstaining material. Secure the valley metal to the roof deck along each edge with fasteners spaced 8"–12" apart. Overlaps should be 12" and cemented. See Fig. 9.

Fig. 9 Open Valley Construction Construcción con canal descubierto

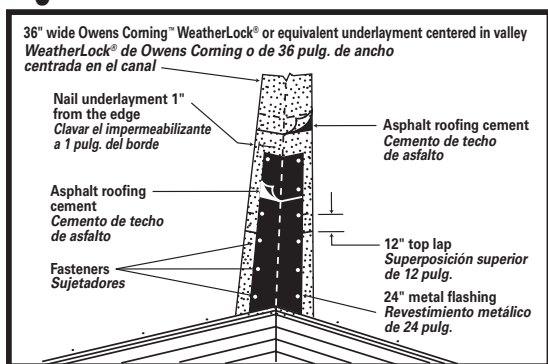

Snap a chalk line on each side of the valley centerline over the full length of the valley flashing. Space the chalk lines 6" apart at the ridge (3" to either side of the valley centerline). The lower ends of the chalk lines should diverge from each other $\frac{1}{8}$ " per foot (i.e., for an 8' valley the chalk lines will be 7" apart at the eaves). See Fig. 9A.

Fig. 9A Open Valley Construction
Construcción con canal descubierto

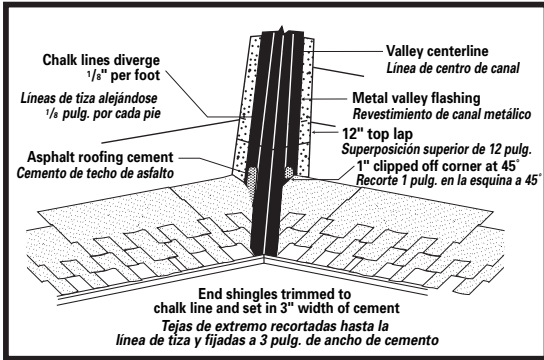

As the shingles are applied toward the valley, the last shingle in each course will be trimmed to fit on the chalk line. **Note: Do not use a shingle less than 12" in length to finish a course running into a valley.** If necessary, trim a tab off the adjacent shingle in the course to allow a longer portion to be used.

Clip 1" from the upper portion of the shingle on a 45° angle to divert water into the valley. See Fig. 9A.

Cement the shingle to the valley lining with a 3" wide band of asphalt plastic cement conforming to ASTM D4586, Type I or II. See Fig. 9A.

Closed-Cut Valley See Fig. 9B.

Fig. 9B Closed-Cut Valley Construction
Construcción con canal de corte cerrado

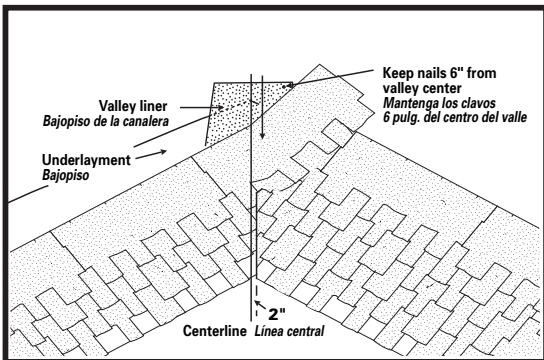

A closed-cut valley can be used as an alternative and is applied as follows:

Lay a 36" wide valley liner of Owens Corning® WeatherLock® underlayment or equivalent. A 36" wide minimum 50-lb. smooth surface roll roofing can also be used as a valley liner.

Lay all shingles on one side of valley and across centerline of valley a minimum of 12". Fasten a minimum of 6" away from centerline on each side of valley.

Strike a chalk line 2" from the centerline of the unshingled side. Apply shingles on the unshingled side up to the chalk line and trim, taking care not to cut the underlying shingles. Clip upper corners of these shingles, cement and fasten.

Both woven and metal valleys are acceptable alternatives.

10. Step Flashing:

Use 5" x 6" corrosion-resistant metal where roof planes butt against vertical sidewalls or chimneys. See Fig. 10.

Fig. 10 Step Flashing
Revestimiento escalonado

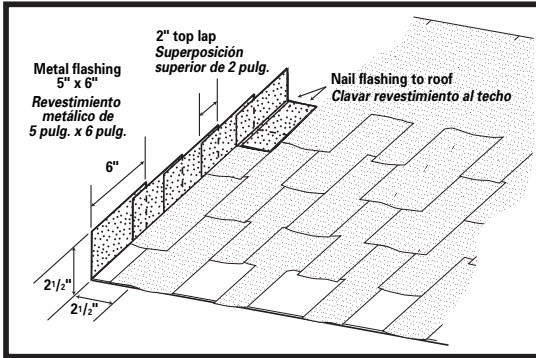

11. Hip & Ridge Application:

Use Owens Corning® DecoRidge® Hip & Ridge shingles.

Follow the application instructions as printed on the DecoRidge® Hip & Ridge carton.

Devonshire® Shingles

Application Instructions

Before installing this product, check local building codes for their roofing requirements. These shingles are designed for new or reroofing work over any properly built and supported wood roof deck having adequate nail holding capacity and a smooth surface. Check local building codes.

Precautionary Note:

The manufacturer will not be responsible for problems resulting from any deviation from the recommended application instructions and the following precautions:

Roof Top Loading: Lay shingle bundles flat. Do not bend over the ridge.

Roof Deck: ▪ 6" Minimum roof deck boards ▪ Minimum $\frac{3}{8}$ " plywood ▪ Minimum $\frac{7}{16}$ " OSB

Regardless of deck type used, the roofing installer must:

1. Install the deck material in strict compliance with the deck manufacturer's instructions.
2. Prevent the deck from getting wet before, during and after installation.

Ventilation: Must meet local building codes.

Handling: Use extra care in handling shingles when the temperature is below 40°F.

Storage: Store in a covered ventilated area at a maximum temperature of 110°F. Bundles should be stacked flat. Protect shingles from weather when stored at the job site. Do not store near steam pipes, radiators, etc.

Fastener requirement: Use galvanized steel, stainless steel, or aluminum nails minimum 12 gauge shank with $\frac{3}{8}$ " diameter head. Owens Corning Roofing recommends that fasteners comply with ASTM F1667. Check local building codes.

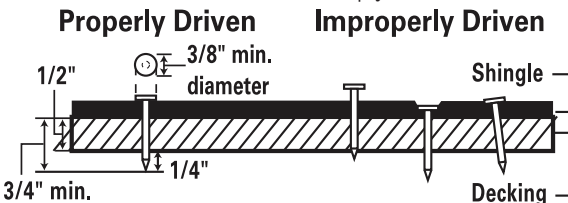

All Fasteners must penetrate at least $\frac{3}{4}$ " into the wood deck or completely through plywood sheathing.

Notice: Owens Corning Roofing recommends the use of nails as the preferred method of attaching shingles to wood decking or other nailable surfaces.

1. Specialty Eave Flashing:

When required by code.

WeatherLock® Underlayment or equivalent eave and flashing membrane applied to a point at least 24" beyond interior wall line. See manufacturer's installation instructions. See Fig. 1.

Fig. 1 Specialty Eave Flashing
Tapajuntas especial para aleros

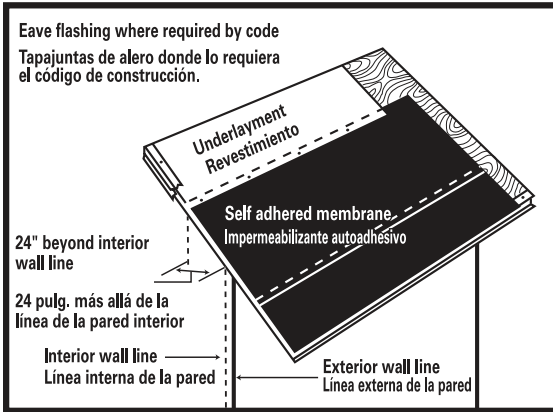

2. Underlayment:

Standard Slope (4" in 12" or more) Application of underlayment, metal drip edges, and eaves flashing: See Fig. 2.

(A) Apply one layer of underlayment over metal drip edge at eaves. Use only enough fasteners to hold in place.

(B) Overlap successive courses 2". Overlap course ends 4". Side laps are to be staggered 6' apart.

(C) Apply metal drip edge over underlayment at rake.

Fig. 2 Underlayment Standard Slope
Revestimiento para pendientes estándar

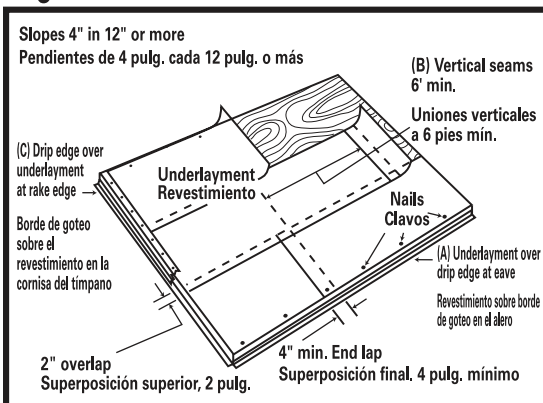

3. Underlayment:

Low Slope (2" in 12" to less than 4" in 12").

Application of roofing felt overlapped by 19 inches on each course. See Fig. 3.

- (A) Apply 19" starter strip of underlayment over metal drip edge at eaves. Use only enough fasteners to hold it in place.
- (B) Use 36" strips of underlayment for remaining courses, overlapping each course 19." Side laps are to be staggered 6' apart.
- (C) Apply metal drip edge over underlayment at rake.

Or WeatherLock® self-adhered underlayment or equivalent with a standard overlap of 3 inches and metal drip edge. See Fig. 3A.

Fig. 3 Underlayment Low Slope Revestimiento para pendientes bajas

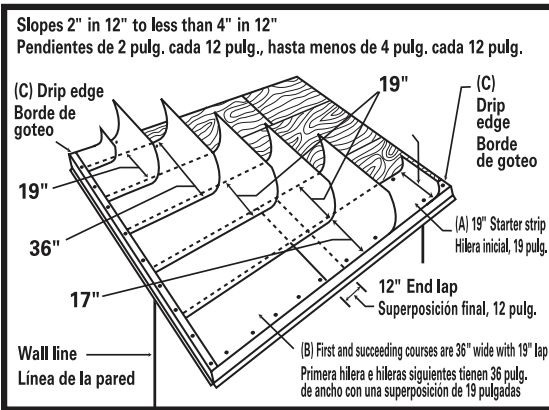

Fig. 3A Underlayment Low Slope Revestimiento para pendientes bajas

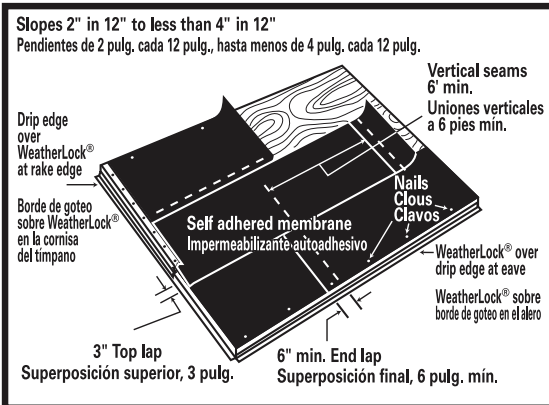
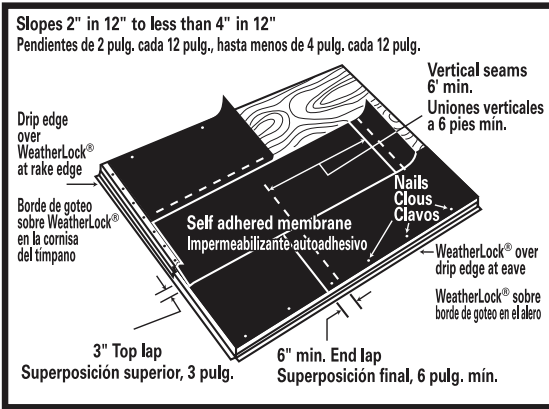

Fig. 3A Underlayment Low Slope Revestimiento para pendientes bajas



4. Chalk Lines:

When laying out the application of Owens Corning® Devonshire® shingles, vertical chalk lines must be snapped. These chalk lines will be spaced as follows: From the rake edge, measure 15½" and snap a chalk line. From the rake edge again, measure 27½" and snap a second chalk line, and once more from the rake edge, measure 39½" and snap a third and final chalk line. This will be the layout for installing the shingles offset pattern. See Fig. 4.

Fig. 4 Chalk Lines Líneas de tiza

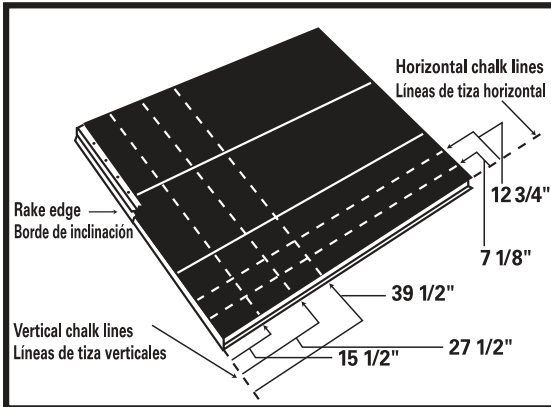

5. Shingle Fastening:

Standard Fastening Pattern.

Place fasteners ⅝" above the tab cutout and below the lower edge of the sealant strip. Fastening into the sealant strip interferes with sealing and contributes to blow-offs. See Fig. 5.

Note: Do not drive fasteners into or above the sealant strip.
Mansard or Steep Slope Fastening Pattern.

REQUIRED: For slopes exceeding 60 degrees or 21 inches per foot, use ten spots of asphalt cement per shingle. Apply immediately; two 1" diameter spot of asphalt roof cement **under** the shingle tab. Center the asphalt cement 2" up from the bottom edge of the shingle tab. See Fig. 5A.

Roof Cement where required must meet ASTM D4586 Type I or II (Asbestos Free).

Fig. 5 Standard Fastening Pattern
Esquema de fijación estándar

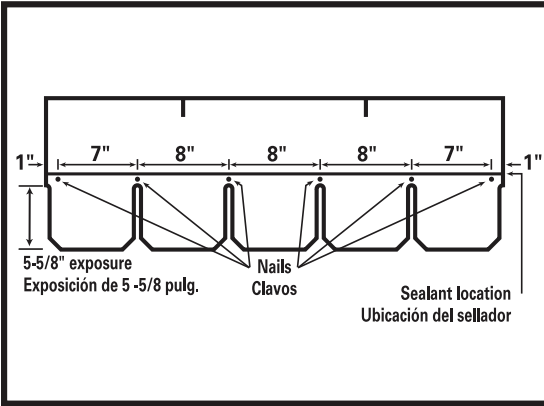
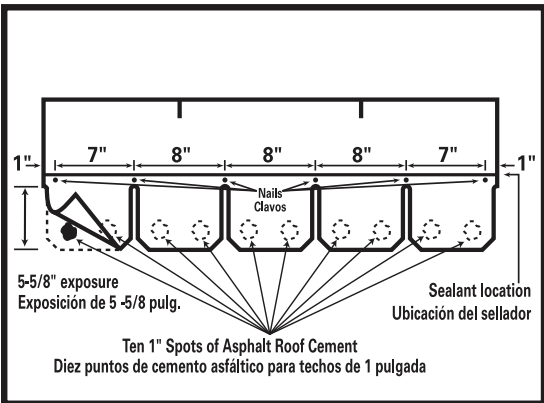

Fig. 5A Mansard or Steep Slope Fastening Pattern
Esquema de instalación en pendientes pronunciadas o mansardas



6. Shingle Application:

Starter Course:

Note: The starter course must be cut from the Owens Corning® Devonshire® shingle. To aid in the application of these shingles, it is recommended that horizontal chalk lines be used. For the starter course, measure 7 1/8" up from the eaves edge and snap a chalk

line. And for the first full shingle course measure $12\frac{3}{4}$ " up from the eaves edge and snap a second chalk mark. Vertical Racking is not permitted.

Trim 12" off the left edge of the starter course shingle; align the top of the shingle with the $7\frac{1}{8}$ " horizontal chalk line and the $27\frac{1}{2}$ " vertical chalk line then nail in place. Nails should be placed 2" to 3" above the cutout with 6 nails per shingle. Once the starter course has been installed trim the overhanging tabs. See Fig. 6.

Fig. 6 Starter Course
Hilera inicial

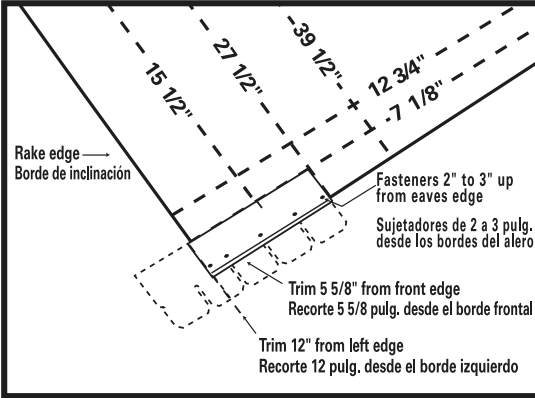
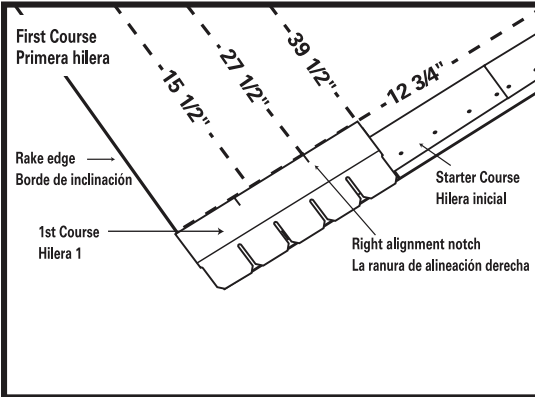

Fig. 6A Shingle Application
Instalación de tejas



First Course:

Apply the first course starting with a full shingle, even with the lower edge of the starter course shingle. Align the top of the shingle with the $12\frac{3}{4}$ " horizontal chalk line. Align the right edge of the shingle with the $39\frac{1}{2}$ " vertical chalk line. This will leave $\frac{1}{2}$ " overhang at the rake. Complete the course with full shingles. See Fig. 6A.

Fasten securely according to fastening instructions. See Fig. 5.

Second Course:

Remove 12" from the left end of the shingle at the left alignment notch. Align the right edge of the shingle with the 27½" vertical chalk line and the right alignment notch on the first course. Align the bottom edge of the shingle with the top of the shingle cutouts in the first course leaving 5⅝" exposure. This will leave ½" overhang at the rake. Complete the course with full shingles. See Fig. 6B.

Fasten securely according to fastening instructions. See Fig. 5.

Fig. 6B Shingle Application
Instalación de tejas

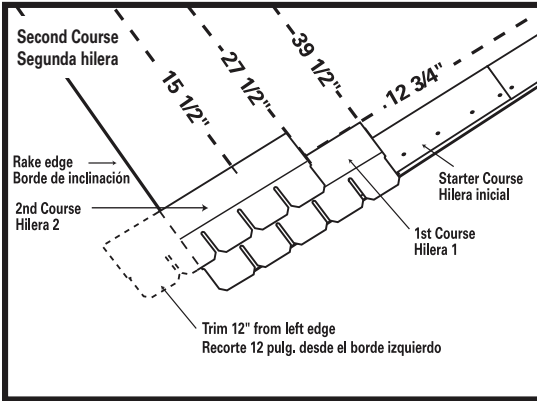

Third Course:

Remove 24" from the left end of the shingle. Align the right edge of the shingle with the 15½" vertical chalk line and the right alignment notch on the second course. Align the bottom edge of the shingle with the top of the shingle cutouts in the second course leaving 5⅝" exposure. This will leave ½" overhang at the rake. Complete the course with full shingles. See Fig. 6C.

Fasten securely according to fastening instructions. See Fig. 5.

Fig. 6C Shingle Application
Instalación de tejas

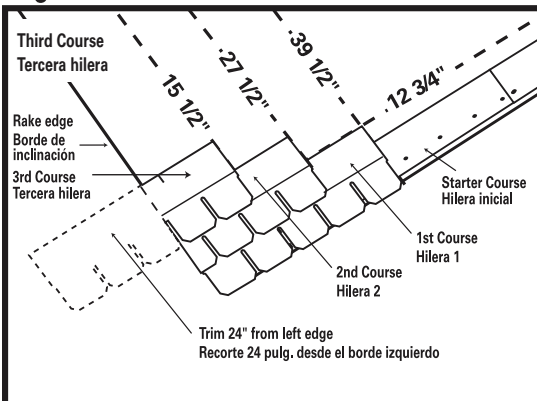

Fourth Course:

Remove 12" from the left end of the shingle at the left alignment notch. Align the right edge of the shingle with the 27½" vertical chalk line. Align the bottom edge of the shingle with the top of the shingle cutouts in the third course leaving 5⅝" exposure. This will leave ½" overhang at the rake. Complete the course with full shingles. See Fig. 6D.

Fasten securely according to fastening instructions. See Fig. 5.

Succeeding Courses:

For succeeding courses, repeat the first through fourth course. See Fig. 6E

Fig. 6D Shingle Application
Instalación de tejas

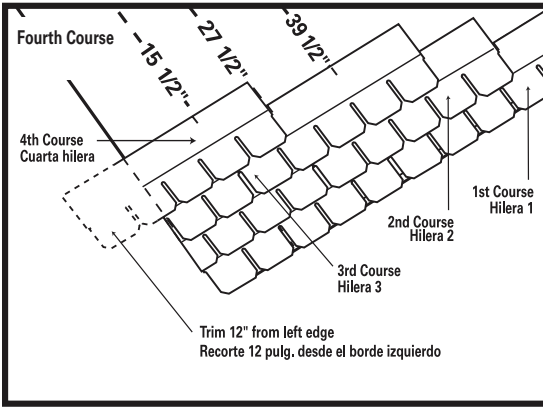
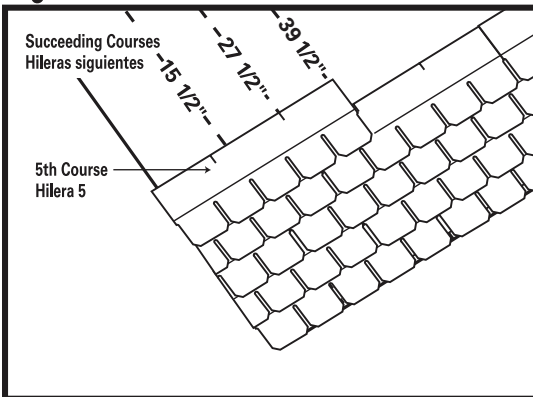

Fig. 6E Shingle Application
Instalación de tejas



7. Valley Construction:

Closed-Cut Valley See Fig. 7.

A closed-cut valley can be used as an alternative to an open valley and is applied as follows:

Lay a 36" wide valley liner of self-adhered membrane underlayment or equivalent. A 36" wide minimum 50 lb. smooth surface roll roofing can also be used as a valley liner.

Lay all shingles on one side of valley and across center line of valley a minimum of 12". Fasten a minimum of 6" away from center line on each side of valley. Strike a chalk line 2" from the center line of the unshingled side.

Apply shingles on the unshingled side up to the chalk line and trim, taking care not to cut the underlying shingles. Clip upper corners of these shingles, cement and fasten. Open valleys are acceptable alternatives.

Fig. 7 Closed-Cut Valley Construction
Construcción del valle con corte cerrado

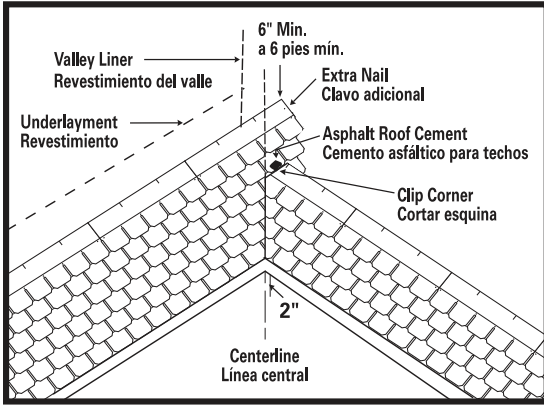

8. Step Flashing:

Use 10" long and 2" wider than expected exposure corrosion-resistant metal where roof planes butt against vertical sidewalls or chimneys. Check local building codes. See Fig. 8.

Fig. 8 Step Flashing
Tapajuntas escalonado

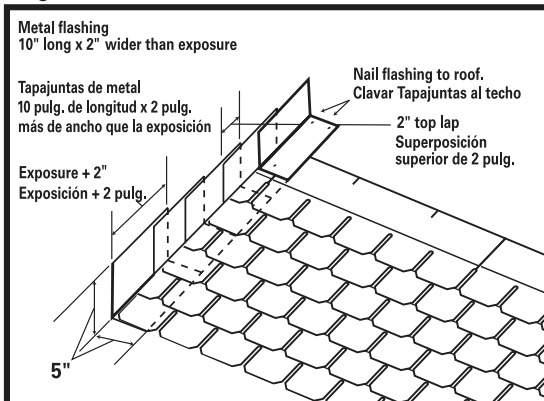

9. Hip & Ridge Application:

Use only Owens Corning® ProEdge® Hip & Ridge Shingles that complement shingle color. Follow specific application instructions as printed on the Hip & Ridge shingle package. See Fig. 9.

Fig. 9 Hip & Ridge Application
Instalación de las tejas de caballete y cumbre

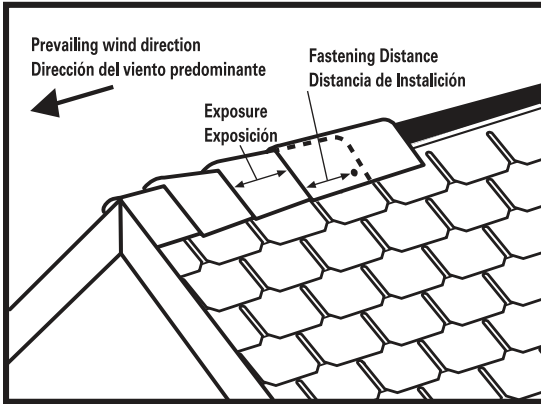

CAUTION

ROOF SURFACE MAY BE SLIPPERY: Especially when wet or icy. Use a fall protection system when installing. Wear rubber soled shoes. Walk with care.

FALLING HAZARD: Secure area below work and materials on roof. Unsecured materials may slide on roof. Place on level plane or secure to prevent sliding. Wear a hard hat.

WARNING: This product contains a chemical known to the State of California to cause cancer.

Duration[®] Series Shingles

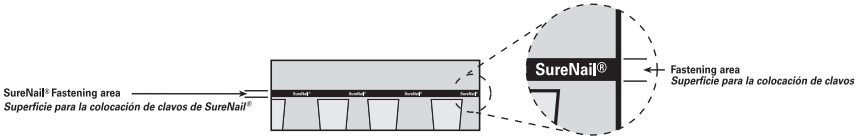

Application Instructions

Before installing this product, check local building codes for their roofing requirements.

These shingles are designed for new or reroofing work over any properly built and supported wood roof deck having adequate nail holding capacity and a smooth surface. Check local building codes.

Precautionary Note:

The manufacturer will not be responsible for problems resulting from any deviation from the recommended application instructions and the following precautions:

Roof Top Loading: Lay shingle bundles flat. Do not bend over the ridge.

Roof Deck: ▪ 6" Maximum roof deck boards ▪ Minimum $\frac{3}{8}$ " plywood ▪ Minimum $\frac{7}{16}$ " OSB

Regardless of deck type used, the roofing installer must:

1. Install the deck material in strict compliance with the deck manufacturer's instructions.
2. Prevent the deck from getting wet before, during and after installation.

Ventilation: Must meet or exceed FHA Minimum Property Standards.

Handling: Use extra care in handling shingles when the temperature is below 40°F.

Shingle Cutting: For best results ensure that all cutting devices are sharp and that when cutting shingles it is best to cut with a quick motion as you pull the roofing knife through the shingle.

Storage: Store in a covered ventilated area at a maximum temperature of 110°F. Bundles should be stacked flat. Protect shingles from weather when stored at the job site. Do not store near steam pipes, radiators, etc.

Fastener requirement: Use galvanized steel, stainless steel, or aluminum nails minimum 12-gauge shank with $\frac{3}{8}$ " diameter head. Owens Corning Roofing recommends that fasteners comply with ASTM F 1667. Check local building codes.

All Fasteners must penetrate at least $\frac{3}{4}$ " into the wood deck or completely through sheathing.

Notice: Owens Corning Roofing recommends the use of nails as the preferred method of attaching shingles to wood decking or other nailable surface.

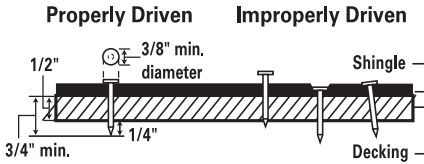

1. Specialty Eave Flashing:

Where required by code.

WeatherLock® underlayment or equivalent eave and flashing membrane applied to a point at least 24" beyond interior wall line. See manufacturer's installation instructions. See Fig. 1.

Fig. 1 Specialty Eave Flashing
Tapajuntas especial para aleros

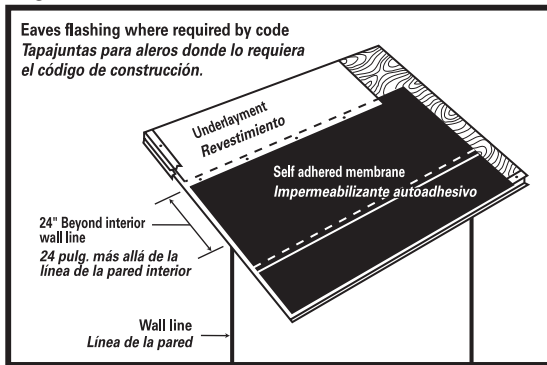

2. Underlayment:

Standard Slope (4" in 12" or more)

Application of underlayment, metal drip edges, and eaves flashing: See Fig. 2.

- (A) Apply one layer of underlayment over metal drip edge at eaves. Use only enough fasteners to hold in place.
- (B) Overlap successive courses 2". Overlap course ends 4". Side laps are to be staggered 6' apart.
- (C) Apply metal drip edge over underlayment at rake.

Fig. 2 Underlayment Standard Slope
Pendiente estándar del revestimiento

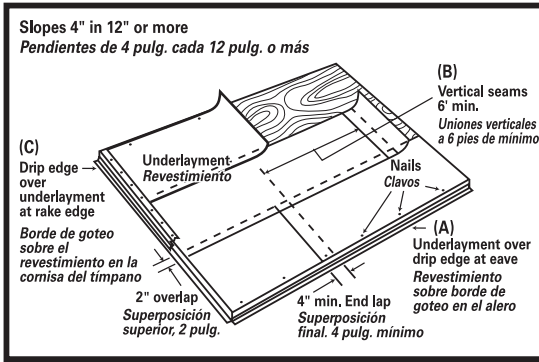

3. Underlayment:

Low Slope (2" in 12" to less than 4" in 12")

Application of roofing felt overlapped by 19 inches on each course. See Fig. 3.

(A) Apply 19" starter strip of underlayment over metal drip edge at eaves. Use only enough fasteners to hold it in place.

(B) Use 36" strip of underlayment for remaining courses, overlapping each course 19". Side laps are to be staggered 6' apart.

(C) Apply metal drip edge over underlayment at rake.

Or WeatherLock® self-adhered underlayment or equivalent with a standard overlap of 3 inches and metal drip edge. See Fig. 3A.

Fig. 3 Underlayment Low Slope
Pendiente baja del revestimiento

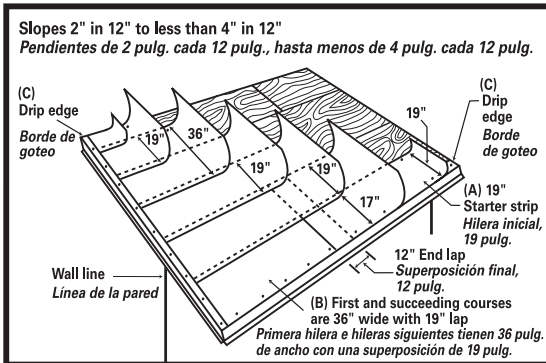
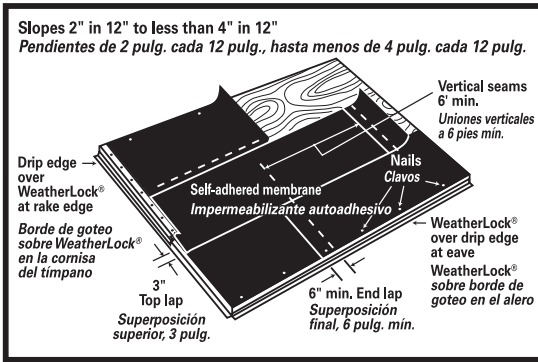

Fig. 3A Underlayment Low Slope
Pendiente baja del revestimiento



4. Shingle Fastening Pattern:

Standard Fastening Pattern.

Fasteners must be placed in the SureNail® fastening area. See Fig. 4.

Six Nail Fastening Pattern.

For 6 nail fastening pattern. See Fig. 4A.

Mansard or Steep Slope Fastening Pattern. Place fasteners 6 1/8" from bottom edge to secure both layers of the shingle. Fasteners need to be located 6 1/8" above the butt edge of the shingle, regardless of whether they are in the granules or the SureNail® fastening area. See Fig. 4B.

Shingle Side View



REQUIRED: For slopes exceeding 60 degrees or 21" per foot, use six fasteners and four spots of asphalt cement per shingle. Apply immediately; one 1" diameter spot of asphalt cement **under** each shingle tab. Center asphalt roof cement 2" up from bottom edge of shingle tab.

Roof Cement where required must meet ASTM D-4586 Type I or II (Asbestos Free).

Fig. 4 Standard Fastening Pattern
Esquema de instalación estándar

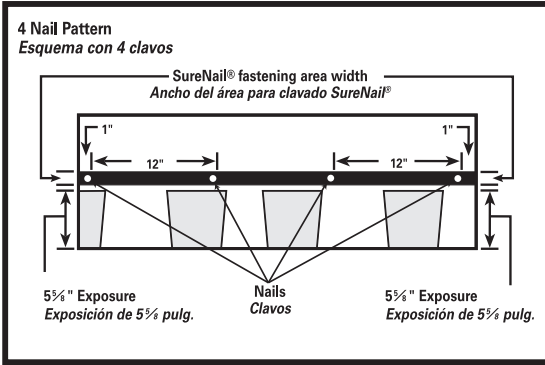

Fig. 4A Six Nail Fastening Pattern
Esquema de instalación con seis clavos

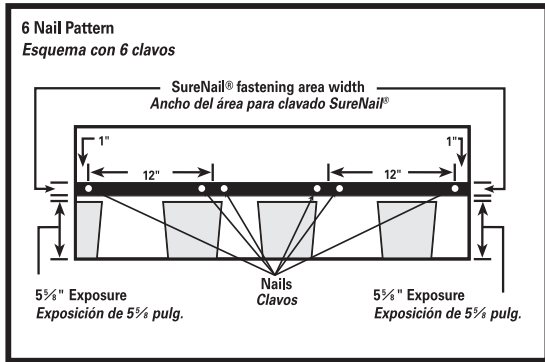
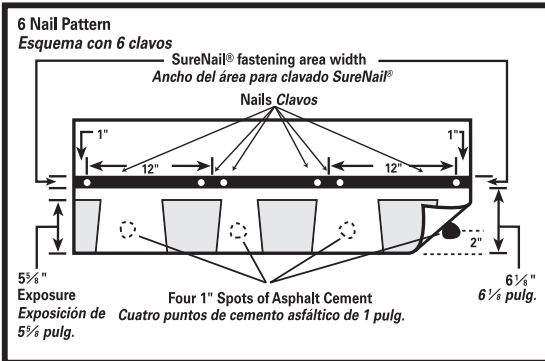

Fig. 4B Mansard or Steep Slope Fastening Pattern
Esquema de instalación en pendientes pronunciadas o mansardas



5. Shingle Application:

These shingles are applied with a $6\frac{1}{2}$ " offset, with $5\frac{5}{8}$ " exposure, over prepared roof deck, starting at the bottom of the roof and working across and up. This will blend shingles from one bundle into the next and minimize any normal shade variation. Application with offsets of 4" or 5" are also acceptable.

Caution must be exercised to assure that end joints are no closer than 2" from fastener in the shingle below and that side laps are no less than 4" in succeeding courses. Refer to course application steps for specific instructions.

Starter Course:

Use starter roll or trim $5\frac{5}{8}$ " from the starter course shingle. Trim $6\frac{1}{2}$ " off the rake of the starter course shingle and flush with the drip edge along the rake and eaves edge, and continue across the roof. Use 5 fasteners for each shingle, placed 2" to 3" up from eaves edge. See Fig. 5. **(If no drip edge is used, shingles must extend a minimum of $\frac{1}{2}$ " and no more than 1" from rake and eaves edge.)**

First Course:

Apply first course starting with the full shingle even with the starter course. See Fig. 5A.

Fasten securely according to fastening instructions. See Fig. 4.

Fig. 5 Shingle Application
Instalación de tejas

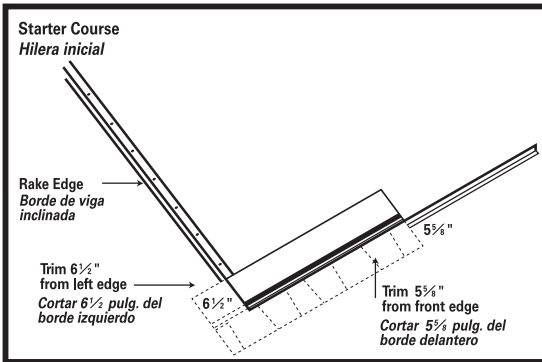
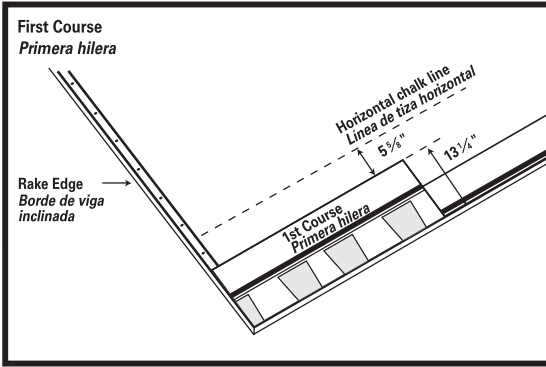

Fig. 5A Shingle Application
Instalación de tejas



Second Course:

Remove $6\frac{1}{2}"$ from the left end of this shingle and apply the remaining piece over and above the first course shingle and flush with edge of the first course with $5\frac{5}{8}"$ exposure. See Fig. 5B.

Fasten securely according to fastening instructions. See Fig. 4.

Fig. 5B Shingle Application
Instalación de tejas

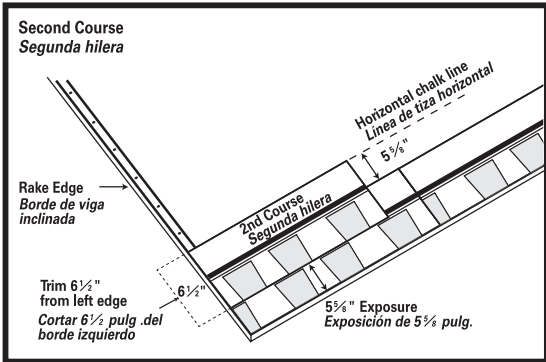

Fig. 5C Shingle Application
Instalación de tejas

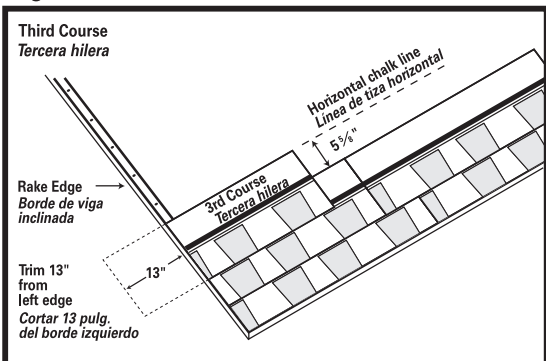
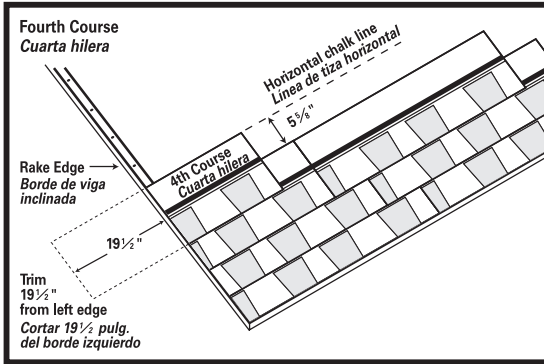

Fig. 5D Shingle Application
Instalación de tejas



Third Course:

Remove 13" from the left end of this shingle and apply the remaining piece over and above the second course shingle flush with edge of the second course with $5\frac{5}{8}$ " exposure. See Fig. 5C.

Fasten securely according to fastening instructions. See Fig. 4.

Fourth Course:

Remove $19\frac{1}{2}$ " from the left end of this shingle and apply the remaining piece over and above the third course shingle and flush with edge of the third course with $5\frac{5}{8}$ " exposure. See Fig. 5D.

Fasten securely according to fastening instructions. See Fig. 4.

Fifth Course:

Remove 26" from the left end of this shingle and apply the remaining piece over and above the fourth course shingle and flush with edge of the fourth course with $5\frac{5}{8}$ " exposure. See Fig. 5E.

Fasten securely according to fastening instructions. See Fig. 4.

Fig. 5E Shingle Application
Instalación de tejas

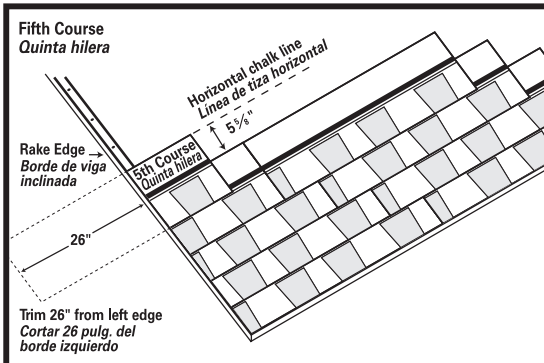

Sixth Course:

Remove $32\frac{1}{2}$ " from the left end of this shingle and apply the remaining piece over and above the fifth course shingle and flush with edge of the fifth course with $5\frac{5}{8}$ " exposure. See Fig. 5F.

Fasten securely according to fastening instructions. See Fig. 4.

Fig. 5F Shingle Application
Instalación de tejas

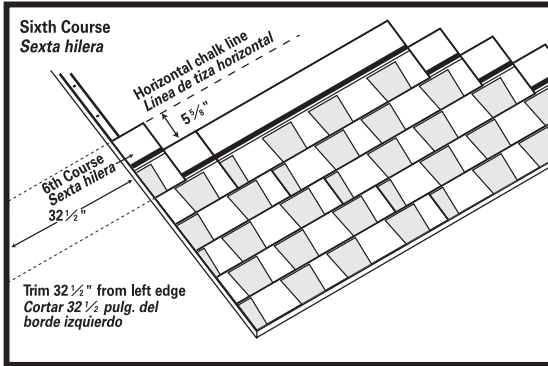

Succeeding Courses:

For succeeding courses, repeat first through sixth course. See Fig. 5G.

Fig. 5G Shingle Application
Instalación de tejas

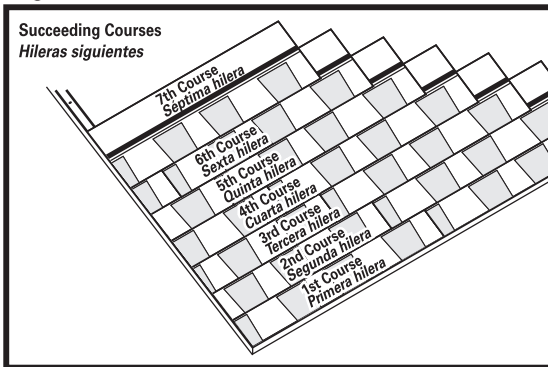

6. Valley Construction:

Closed-Cut Valley See Fig. 6.

A closed-cut valley can be used as an alternative to woven or open valley and is applied as follows:

Lay a 36" wide valley liner of self-adhered membrane underlayment or equivalent. A 36" wide minimum 50 lb. roll roofing can also be used as a valley liner.

Lay all shingles on one side of valley and across center line of valley a minimum of 12". Fasten a minimum of 6" away from center line on each side of valley.

Strike a chalk line 2" from the center line of the unshingled side. Apply shingles on the unshingled side up to the chalk line and trim, taking care not to cut the underlying shingles. Clip upper corners of these shingles, cement and fasten.

Both woven and metal valleys are acceptable alternatives.

Fig. 6 Closed-Cut Valley Construction
Construcción del valle con corte cerrado

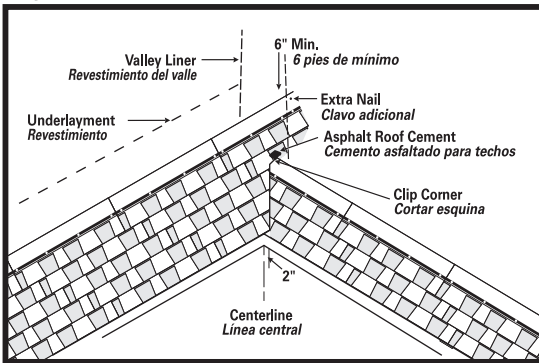

7. Step Flashing:

Use 10" long and 2" wider than expected exposure corrosion-resistant metal where roof planes butt against vertical sidewalls or chimneys. See Fig. 7. Check local building codes.

Fig. 7 Step Flashing
Tapajuntas escalonado

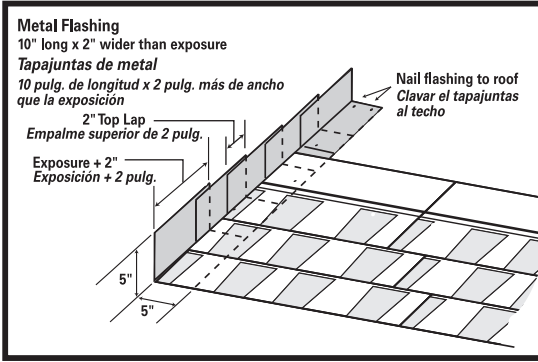

8. Hip & Ridge Application:

Use corresponding Owens Corning® Hip & Ridge shingles to best complement shingle color. Follow specific application instructions as printed on the Hip & Ridge shingle package. See Fig. 8.

Fig. 8 Hip & Ridge Application
Instalación de caballetes y cumbreras

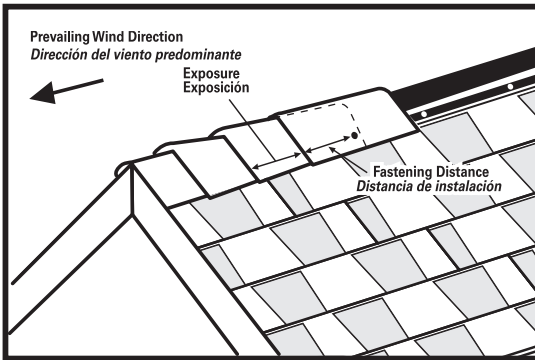

CAUTION

ROOF SURFACE MAY BE SLIPPERY: Especially when wet or icy. Use a fall protection system when installing. Wear rubber soled shoes. Walk with care.

FALLING HAZARD: Secure area below work and materials on roof. Unsecured materials may slide on roof. Place on level plane or secure to prevent sliding. Wear a hard hat.

WARNING: This product contains a chemical known to the State of California to cause cancer.

TruDefinition® Duration STORM® Shingles

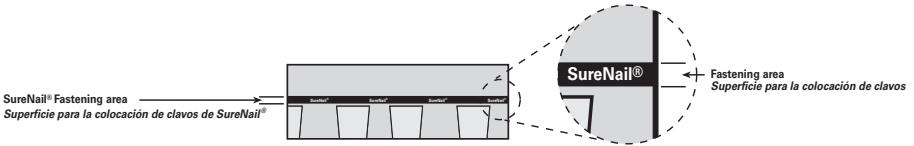

Application Instructions

Before installing this product, check local building codes for their roofing requirements.

These shingles are designed for new or reroofing work over any properly built and supported wood roof deck having adequate nail holding capacity and a smooth surface. Check local building codes.

Precautionary Note:

The manufacturer will not be responsible for problems resulting from any deviation from the recommended application instructions and the following precautions:

- The existing roof must be removed before installing Duration STORM® shingles.
- Use of shingle over ridge vent will affect the impact resistance classification of the Owens Corning® Impact-Resistant Hip & Ridge Shingles; use off-ridge ventilation products as an alternative.
- Spacing between the decking at the ridge should not be more than 1/4" because it could affect the impact resistance classification.
- Owens Corning® Impact-Resistant Hip & Ridge Shingles must be used.

Roof Top Loading: Lay shingle bundles flat. Do not bend over the ridge.

Roof Deck: ▪ Recommended roof decks are 6" minimum width, 25/32" minimum thickness wood sheathing. ▪ Minimum 3/8" plywood ▪ Minimum 7/16" OSB

Regardless of deck type used, the roofing installer must:

1. Install the deck material in strict compliance with the deck manufacturer's instructions.
2. Prevent the deck from getting wet before, during and after installation.

Ventilation: Must meet local building codes.

Handling: Use extra care in handling shingles when the temperature is below 40°F.

Shingle Cutting: For best results ensure that all cutting devices are sharp and that when cutting shingles it is best to cut with a quick motion as you pull the roofing knife through the shingle.

Storage: Store in a covered ventilated area at a maximum temperature of 110°F.

Bundles should be stacked flat. Protect shingles from weather when stored at the job site. Do not store near steam pipes, radiators, etc.

Fastener requirement: Use galvanized steel, stainless steel, or aluminum nails minimum 12 gauge shank with $\frac{3}{8}$ " diameter head. Owens Corning® Roofing recommends that fasteners comply with ASTM F1667. Check local building codes.

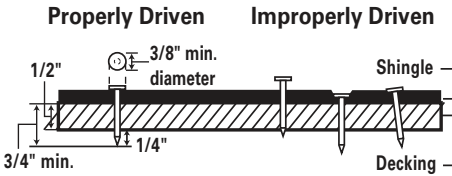

All Fasteners must penetrate at least $\frac{3}{4}$ " into the wood deck or completely through sheathing.

Notice: Owens Corning® Roofing recommends the use of nails as the preferred method of attaching shingles to wood decking or other nailable surface.

1. Specialty Eave Flashing:

Where required by code.

WeatherLock® underlayment or equivalent eave and flashing membrane applied to a point at least 24" beyond interior wall line. See manufacturer's installation instructions. See Fig. 1.

Fig. 1 Specialty Eave Flashing
Tapajuntas especial para aleros

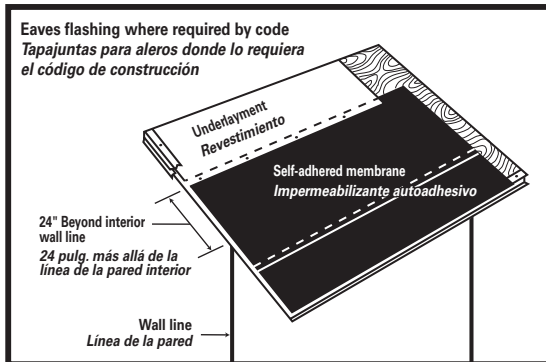

2. Underlayment:

Standard Slope (4" in 12" or more)

Application of underlayment, metal drip edges, and eaves flashing: See Fig. 2.

(A) Apply one layer of underlayment over metal drip edge at eaves. Use only enough fasteners to hold in place.

(B) Overlap successive courses 2". Overlap course ends 4". Side laps are to be staggered 6' apart.

(C) Apply metal drip edge over underlayment at rake.

Fig. 2 Underlayment Standard Slope
Pendiente estándar del revestimiento

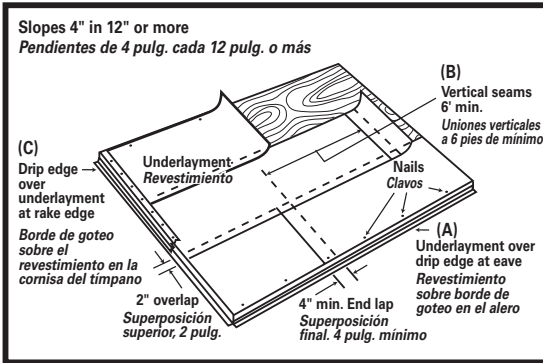

3. Underlayment:

Low Slope (2" in 12" to less than 4" in 12")

Application of roofing felt overlapped by 19" on each course. See Fig. 3.

(A) Apply 19" starter strip of underlayment over metal drip edge at eaves. Use only enough fasteners to hold it in place.

(B) Use 36" strip of underlayment for remaining courses, overlapping each course 19". Side laps are to be staggered 6' apart.

(C) Apply metal drip edge over underlayment at rake.

Or WeatherLock® self-adhered underlayment or equivalent with a standard over lap of 3" and metal drip edge. See Fig. 3A.

Fig. 3 Underlayment Low Slope
Pendiente baja del revestimiento

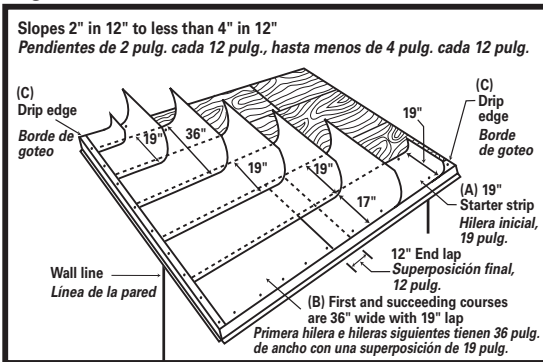
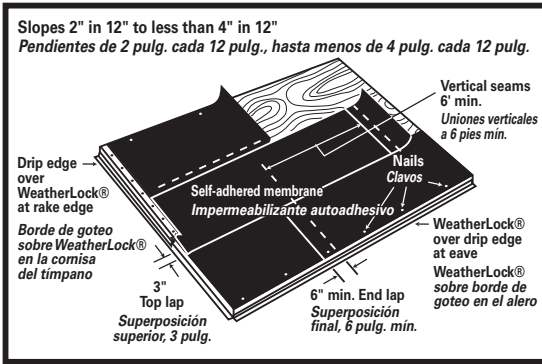

Fig. 3A Underlayment Low Slope
Pendiente baja del revestimiento



4. Shingle Fastening Pattern:

Standard Fastening Pattern.

Fasteners must be placed in the SureNail® fastening area. See Fig. 4.

Six Nail Fastening Pattern.

For 6 nail fastening pattern. See Fig. 4A.

Mansard or Steep Slope Fastening Pattern. Place fasteners 6 1/8" from bottom edge to secure both layers of the shingle. Fasteners need to be located 6 1/8" above the butt edge of the shingle, regardless of whether they are in the granules or the SureNail® fastening area. See Fig. 4B.

Shingle Side View



REQUIRED: For slopes exceeding 60 degrees or 21 inches per foot, use six fasteners and four spots of asphalt cement per shingle. Apply immediately; one 1" diameter spot of asphalt cement **under** each shingle tab. Center asphalt roof cement 2" up from bottom edge of shingle tab.

Roof Cement where required must meet ASTM D-4586 Type I or II (Asbestos Free).

Fig. 4 Standard Fastening Pattern
Esquema de instalación estándar

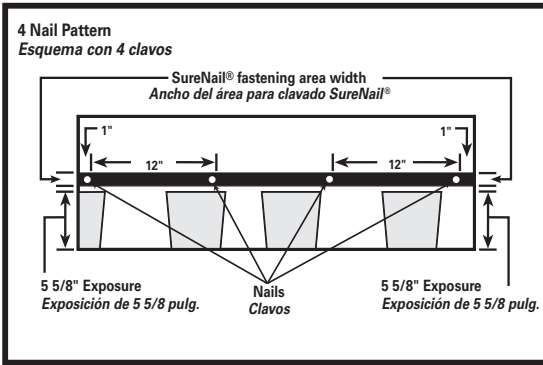

Fig. 4A Six Nail Fastening Pattern
Esquema de instalación con seis clavos

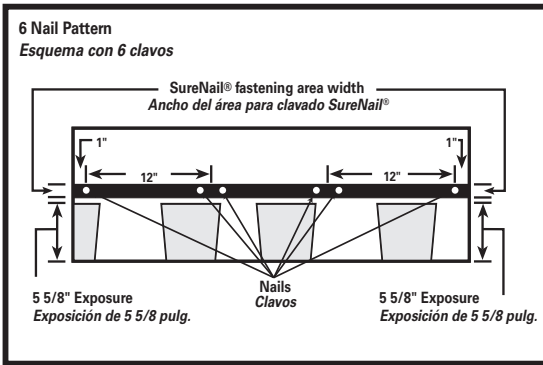
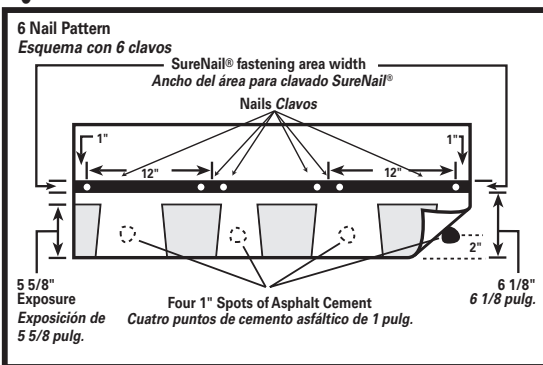

Fig. 4B Mansard or Steep Slope Fastening Pattern
Esquema de instalación en pendientes pronunciadas o mansardas



5. Shingle Application:

These shingles are applied with a 6 1/2" offset, with 5 5/8" exposure, over prepared roof deck, starting at the bottom of the roof and working across and up. This will blend shingles from one bundle into the next and minimize

any normal shade variation. Application with offsets of 4" or 5" are also acceptable.

Caution must be exercised to assure that end joints are no closer than 2" from fastener in the shingle below and that side laps are no less than 4" in succeeding courses. Refer to course application steps for specific instructions.

Starter Course:

Use starter roll or trim 5⁵/₈" from the starter course shingle. Trim 6¹/₂" off the rake of the starter course shingle and flush with the drip edge along the rake and eaves edge, and continue across the roof. Use 5 fasteners for each shingle, placed 2" to 3" up from eaves edge. See Fig. 5. **(If no drip edge is used, shingles must extend a minimum of 1/2" and no more than 1" from rake and eaves edge.)**

First Course:

Apply first course starting with the full shingle even with the starter course. See Fig. 5A.

Fasten securely according to fastening instructions. See Fig. 4.

Fig. 5 Shingle Application
Instalación de tejas

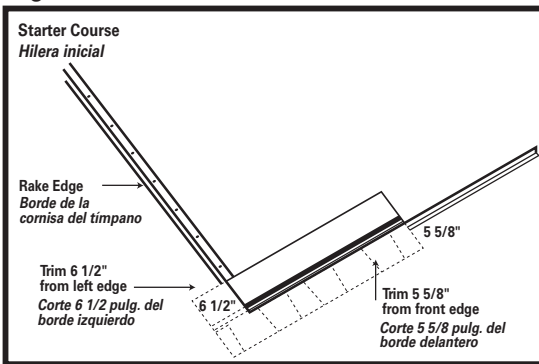
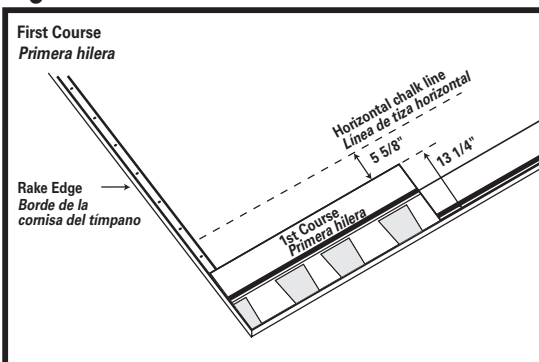

Fig. 5A Shingle Application
Instalación de tejas



Second Course:

Remove 6½" from the left end of this shingle and apply the remaining piece over and above the first course shingle and flush with edge of the first course with 5⅝" exposure. See Fig. 5B.

Fasten securely according to fastening instructions. See Fig. 4.

Third Course:

Remove 13" from the left end of this shingle and apply the remaining piece over and above the second course shingle flush with edge of the second course with 5⅝" exposure. See Fig. 5C.

Fasten securely according to fastening instructions. See Fig. 4.

Fig. 5B Shingle Application
Instalación de tejas

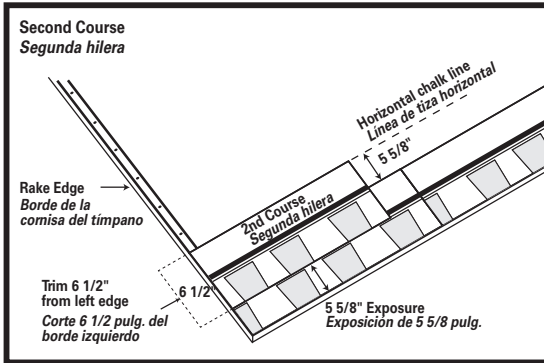
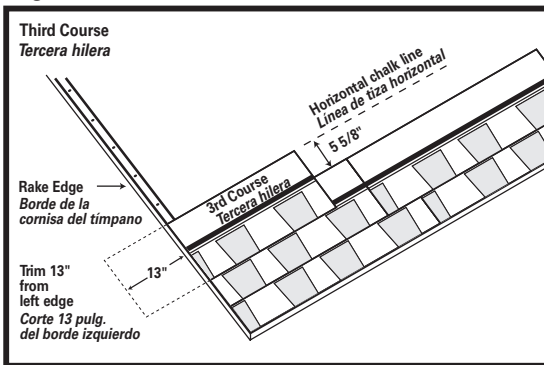

Fig. 5C Shingle Application
Instalación de tejas



Fourth Course:

Remove 19½" from the left end of this shingle and apply the remaining piece over and above the third course shingle and flush with edge of the third course with 5⅝" exposure. See Fig. 5D.

Fasten securely according to fastening instructions. See Fig. 4.

Fig. 5D Shingle Application
Instalación de tejas

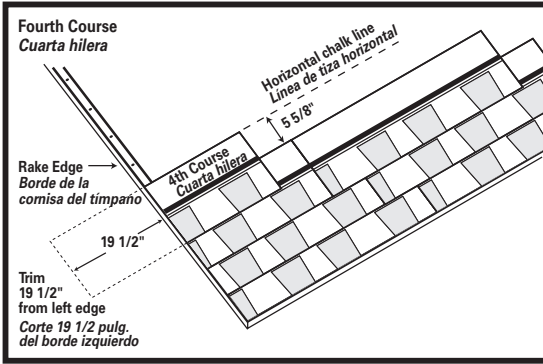

Fifth Course:

Remove 26" from the left end of this shingle and apply the remaining piece over and above the fourth course shingle and flush with edge of the fourth course with $5\frac{5}{8}"$ exposure. See Fig. 5E.

Fasten securely according to fastening instructions. See Fig. 4.

Fig. 5E Shingle Application
Instalación de tejas

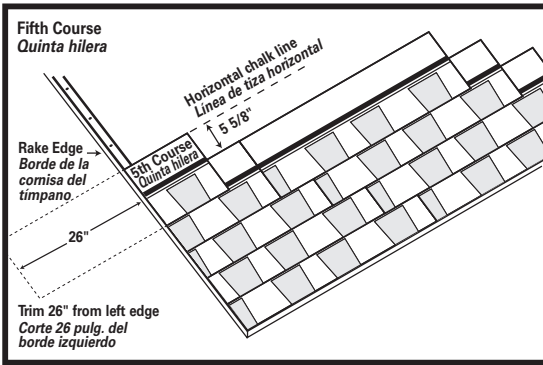

Sixth Course:

Remove $32\frac{1}{2}"$ from the left end of this shingle and apply the remaining piece over and above the fifth course shingle and flush with edge of the fifth course with $5\frac{5}{8}"$ exposure. See Fig. 5F.

Fasten securely according to fastening instructions. See Fig. 4.

Fig. 5F Shingle Application
Instalación de tejas

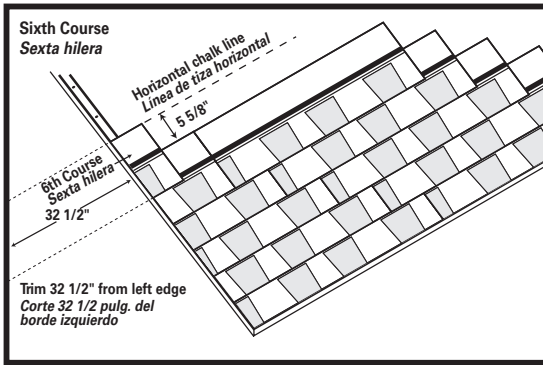

Succeeding Courses:

For succeeding courses, repeat first through sixth course. See Fig. 5G.

Fig. 5G Shingle Application
Instalación de tejas

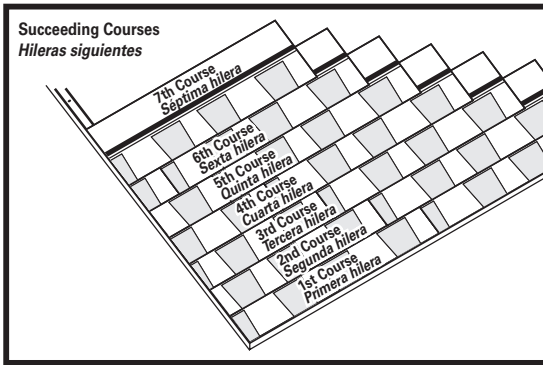

6. Valley Construction:

Closed-Cut Valley See Fig. 6.

A closed-cut valley can be used as an alternative to woven or open valley and is applied as follows:

Lay a 36"-wide valley liner of self-adhered membrane underlayment or equivalent. A 36"-wide minimum 50-lb. roll roofing can also be used as a valley liner.

Lay all shingles on one side of valley and across centerline of valley a minimum of 12". Fasten a minimum of 6" away from centerline on each side of valley.

Strike a chalk line 2" from the centerline of the unshingled side. Apply shingles on the unshingled side up to the chalk line and trim, taking care not to cut the underlying shingles. Clip upper corners of these shingles, cement and fasten.

Both woven and metal valleys are acceptable alternatives.

Fig. 6 Closed-Cut Valley Construction
Construcción del valle con corte cerrado

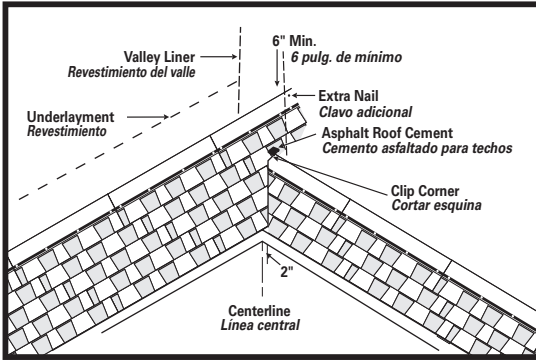

7. Step Flashing:

Use 10" long and 2" wider than expected exposure corrosion-resistant metal where roof planes butt against vertical sidewalls or chimneys. See Fig. 7. Check local building codes.

Fig. 7 Step Flashing
Tapajuntas escalonado

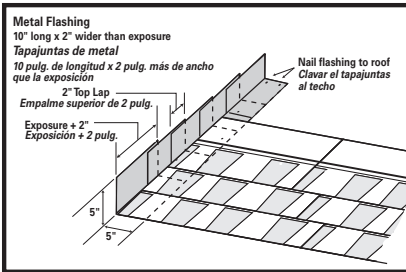

8. Hip & Ridge Application:

Use Owens Corning™ Impact-Resistant Hip & Ridge Shingles to best complement shingle color. Follow specific application instructions as printed on the Hip & Ridge shingle package. See Fig. 8.

Fig. 8 Hip & Ridge Application
Instalación de tejas para caballetes y cumbresras

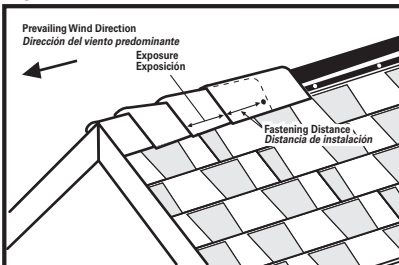

TruDefinition® Duration MAX® Shingles

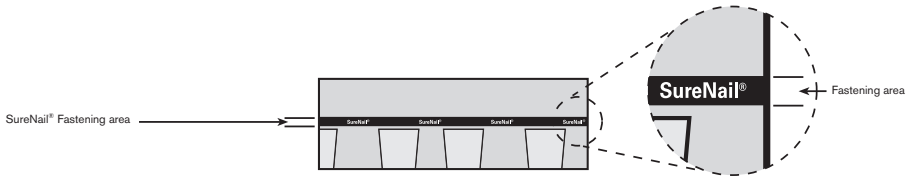

Application Instructions

Before installing this product, check local building codes for their roofing requirements.

These shingles are designed for new or reroofing work over any properly built and supported wood roof deck having adequate nail holding capacity and a smooth surface. Check local building codes.

Precautionary Note:

The manufacturer will not be responsible for problems resulting from any deviation from the recommended application instructions and the following precautions:

Roof Top Loading: Lay shingle bundles flat. Do not bend over the ridge.

Roof Deck: ▪ 6" Minimum roof deck boards ▪ Minimum $\frac{3}{8}$ " plywood ▪ Minimum $\frac{7}{16}$ " OSB

Regardless of deck type used, the roofing installer must:

1. Install the deck material in strict compliance with the deck manufacturer's instructions.
2. Prevent the deck from getting wet before, during and after installation.

Ventilation: Must meet local building codes.

Handling: Use extra care in handling shingles when the temperature is below 40°F.

Shingle Cutting: For best results ensure that all cutting devices are sharp and that when cutting shingles it is best to cut with a quick motion as you pull the roofing knife through the shingle.

Storage: Store in a covered ventilated area at a maximum temperature of 110°F. Bundles should be stacked flat. Protect shingles from weather when stored at the job site. Do not store near steam pipes, radiators, etc.

Fastener Requirement: Use galvanized steel, stainless steel, or aluminum nails minimum 12 gauge shank with $\frac{3}{8}$ " diameter head. Owens Corning Roofing recommends that fasteners comply with ASTM F1667. Check local building codes.

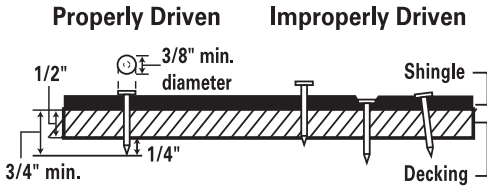

All Fasteners must penetrate at least 3/4" into the wood deck or completely through sheathing.

Notice: Owens Corning Roofing recommends the use of nails as the preferred method of attaching shingles to wood decking or other nailable surface.

1. Specialty Eave Flashing:
Where required by code.

WeatherLock® underlayment or equivalent eave and flashing membrane applied to a point at least 24" beyond interior wall line. See manufacturers installation instructions. See Fig. 1.

FIG 1 Specialty Eave Flashing

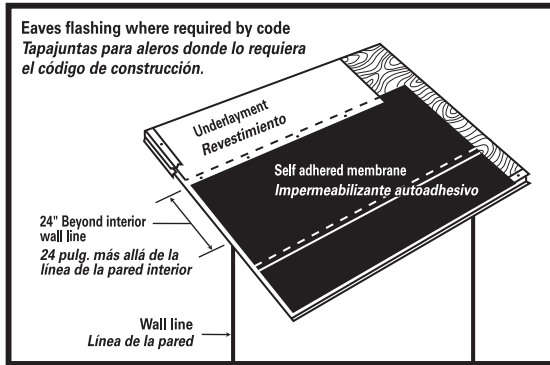

2. Underlayment:

Standard Slope (4" in 12" or more).

Application of underlayment, metal drip edges, and eaves flashing: See Fig. 2.

- (A) Apply one layer of underlayment over metal drip edge at eaves. Use only enough fasteners to hold in place.
- (B) Overlap successive courses 2". Overlap course ends 4". Side laps are to be staggered 6' apart.
- (C) Apply metal drip edge over underlayment at rake.

FIG 2 Underlayment Standard Slope

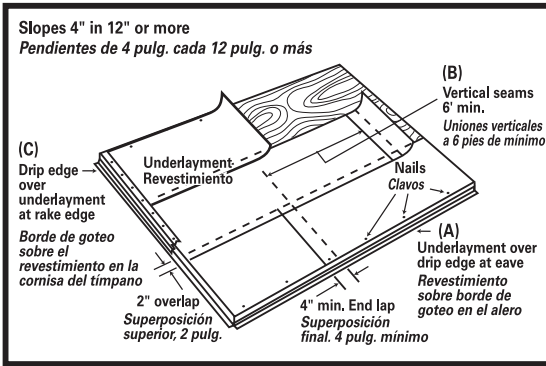

3. Underlayment:

Low Slope (2" in 12" to less than 4" in 12")

Application of roofing felt overlapped by 19 inches on each course. *See Fig. 3.*

- (A) Apply 19" starter strip of underlayment over metal drip edge at eaves. Use only enough fasteners to hold it in place.
 - (B) Use 36" strips of underlayment for remaining courses, overlapping each course 19". Side laps are to be staggered 6' apart.
 - (C) Apply metal drip edge over underlayment at rake.
- Or WeatherLock® self-adhered underlayment or equivalent with a standard overlap of 3 inches and metal drip edge. *See Fig. 3A.*

FIG 3 Underlayment Low Slope

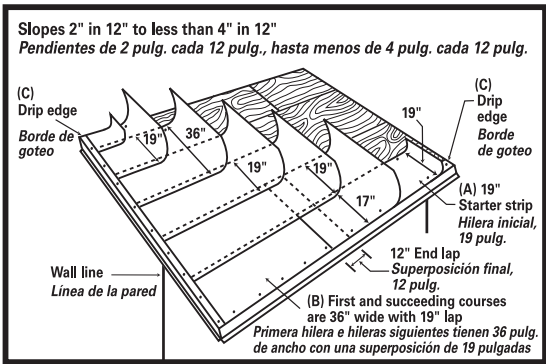
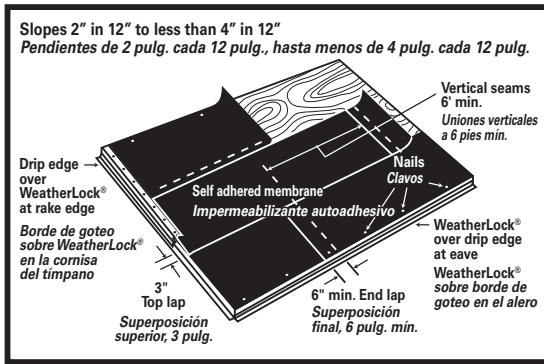

FIG 3A Underlayment Low Slope



4. Shingle Fastening Pattern: Mansard and Steep Slope Fastening Pattern.

Fasteners must be placed in the SureNail® fastening area. See Fig. 4. Six Nail Fastening Pattern.

For 6 nail fastening pattern. See Fig. 4A.

Mansard or Steep Slope Fastening Pattern. Place fasteners 6 1/8" from bottom edge to secure both layers of the shingle. Fasteners need to be located 6 1/8" above the edge of the shingle, regardless of whether they are in the granules or the SureNail® fastening area. See Fig. 4B.

Shingle Side View



REQUIRED: For slopes exceeding 60 degrees or 21 inches per foot, use six fasteners and four spots of asphalt cement per shingle. Apply immediately; one 1" diameter spot of asphalt cement under each shingle tab. Center asphalt roof cement 2" up from bottom edge of shingle tab. Roof Cement where required must meet ASTM D4586 Type I or II (Asbestos Free).

FIG 4 Standard Fastening Pattern

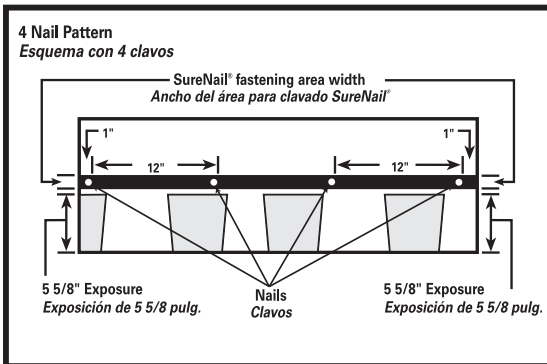

FIG 4A Six Nail Fastening Pattern

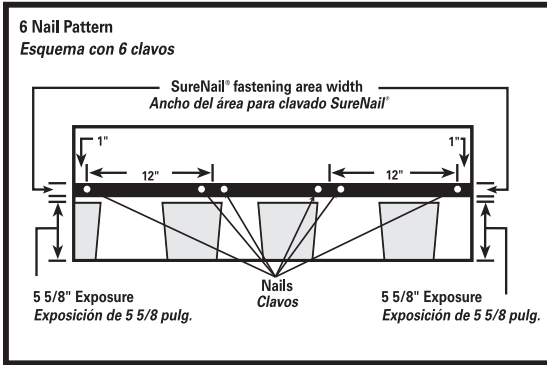
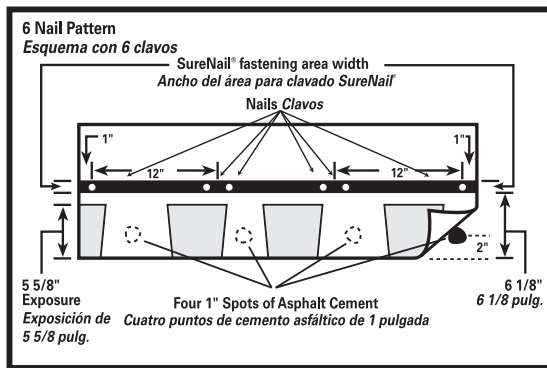

FIG 4B Mansard and Steep Slope Application



5. Shingle Application:

These shingles are applied with a 6 1/2" offset, with 5 5/8" exposure, over prepared roof deck, starting at the bottom of the roof and working across and up. This will blend shingles from one bundle into the next and minimize any normal shade variation. Application with offsets of 4" or 5" are also acceptable.

Caution must be exercised to assure that end joints are no closer than 2" from fastener in the shingle below and that side laps are no less than 4" in succeeding courses. Refer to course application steps for specific instructions.

Starter Course:

Use starter roll, starter strip, or trim 5 5/8" from the starter course shingle. Trim 6 1/2" off the rake of the starter course shingle and flush with the drip edge along the rake and eaves edge, and continue across the roof. Use 5 fasteners for each shingle, placed 2" to 3" up from eaves edge. See Fig. 5. (If no drip edge is used, shingles must extend a minimum of 1/2" and no more than 1" from rake and eaves edge.)

First Course:

Apply first course starting with the full shingle even with the starter course. See Fig. 5A.

Fasten securely according to fastening instructions. See Fig. 4.

FIG 5 Shingle Application

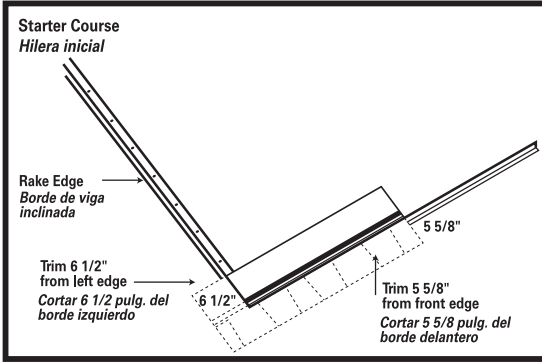

FIG 5A Shingle Application

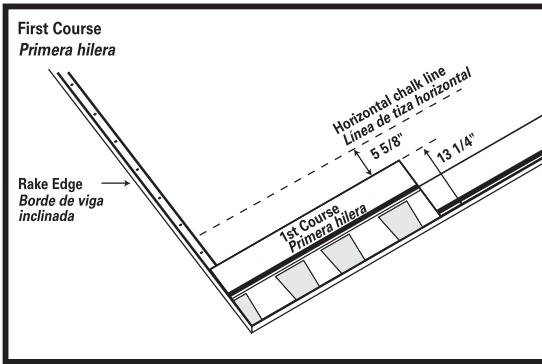

FIG 5B Shingle Application

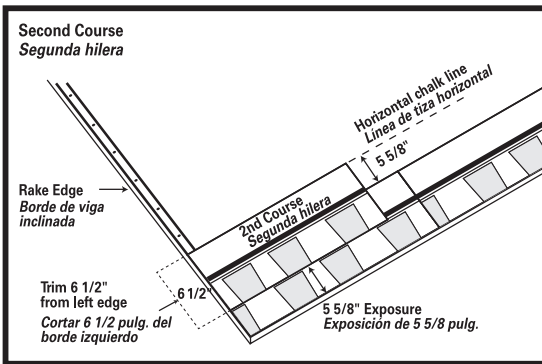
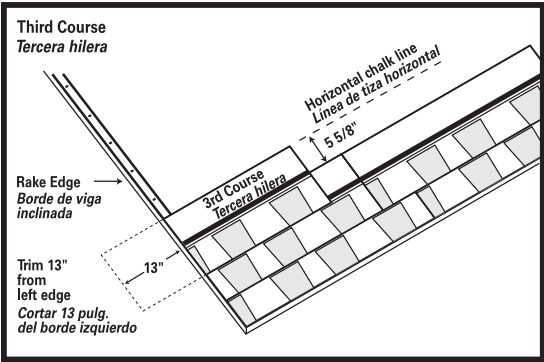

FIG 5C Shingle Application



Second Course:

Remove 6 1/2" from the left end of this shingle and apply the remaining piece over and above the first course shingle and flush with edge of the first course with 5 5/8" exposure. See Fig. 5B.

Fasten securely according to fastening instructions. See Fig. 4.

FIG 5D Shingle Application

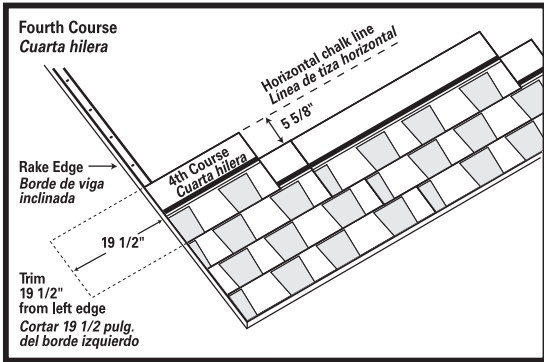

FIG 5E Shingle Application

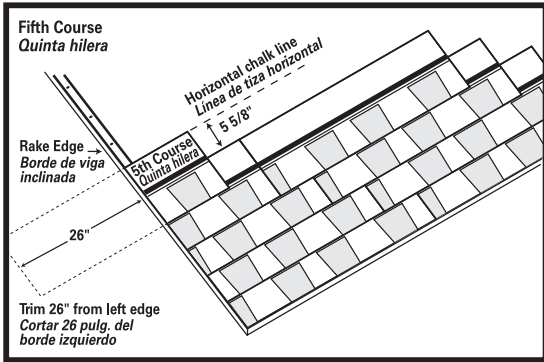

FIG 5F Shingle Application

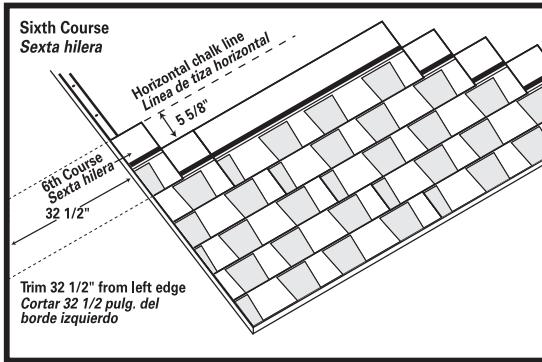
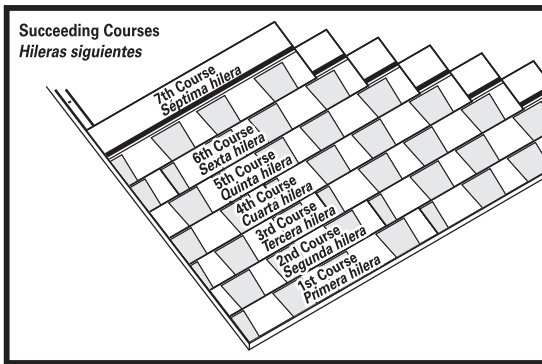

FIG 5G Shingle Application



Third Course:

Remove 13" from the left end of this shingle and apply the remaining piece over and above the second course shingle flush with edge of the second course with $5 \frac{5}{8}$ " exposure. See Fig. 5C.

Fasten securely according to fastening instructions. See Fig. 4.

Fourth Course:

Remove $19 \frac{1}{2}$ " from the left end of this shingle and apply the remaining piece over and above the third course shingle and flush with edge of the third course with $5 \frac{5}{8}$ " exposure. See Fig. 5D.

Fasten securely according to fastening instructions. See Fig. 4.

Fifth Course:

Remove 26" from the left end of this shingle and apply the remaining piece over and above the fourth course shingle and flush with edge of the fourth course with $5 \frac{5}{8}$ " exposure. See Fig. 5E.

Fasten securely according to fastening instructions. See Fig. 4.

Sixth Course:

Remove 32½" from the left end of this shingle and apply the remaining piece over and above the fifth course shingle and flush with edge of the fifth course with 5⅝" exposure. See Fig. 5F.

Fasten securely according to fastening instructions. See Fig. 4.

Succeeding Courses:

For succeeding courses, repeat first through sixth course. See Fig. 5G.

6. Valley Construction:

Closed-Cut Valley See Fig. 6.

A closed-cut valley can be used as an alternative to woven or open valley and is applied as follows:

Lay a 36" wide valley liner of self adhered membrane underlayment or equivalent. A 36"- wide minimum 50-lb. roll roofing can also be used as a valley liner.

Lay all shingles on one side of valley and across center line of valley a minimum of 12". Fasten a minimum of 6" away from center line on each side of valley.

Strike a chalk line 2" from the center line of the unshingled side. Apply shingles on the unshingled side up to the chalk line and trim, taking care not to cut the underlying shingles. Clip upper corners of these shingles, cement and fasten.

Both woven and metal valleys are acceptable alternatives.

FIG 6 Closed-Cut Valley Construction

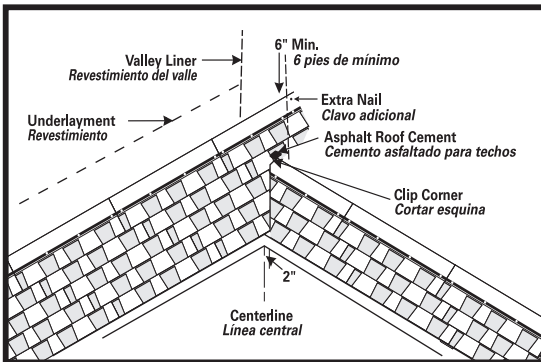

7. Step Flashing:

Use 10" long and 2" wider than expected exposure corrosion-resistant metal where roof planes butt against vertical sidewalls or chimneys. See Fig. 7. Check local building codes.

FIG 7 Step Flashing

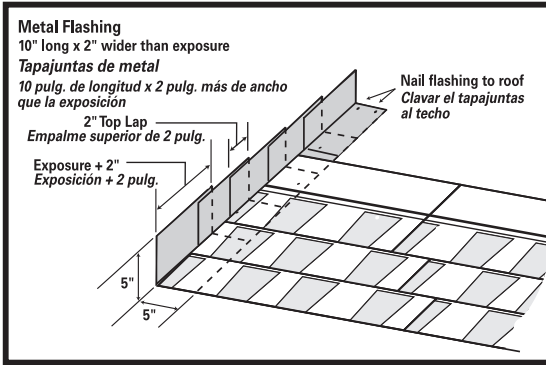

8. Hip & Ridge Application:

Use corresponding Owens Corning® Hip & Ridge Shingles to best complement shingle color. Follow specific application instructions as printed on the Hip & Ridge Shingle package. See Fig. 8.

FIG 8 Hip & Ridge Application

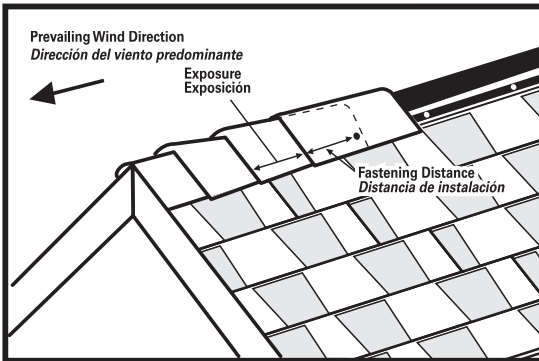

Duration® Premium Shingles

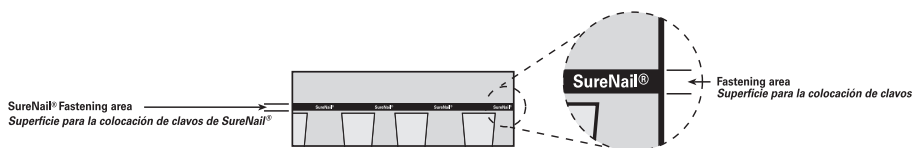

Application Instructions

Before installing this product, check local building codes for their roofing requirements.

These shingles are designed for new or reroofing work over any properly built and supported wood roof deck having adequate nail holding capacity and a smooth surface. Check local building codes.

Precautionary Note:

The manufacturer will not be responsible for problems resulting from any deviation from the recommended application instructions and the following precautions:

Roof Top Loading: Lay shingle bundles flat. Do not bend over the ridge.

Roof Deck: ▪ 6" Minimum roof deck boards ▪ Minimum $\frac{3}{8}$ " plywood ▪ Minimum $\frac{7}{16}$ " OSB

Regardless of deck type used, the roofing installer must:

1. Install the deck material in strict compliance with the deck manufacturer's instructions.
2. Prevent the deck from getting wet before, during and after installation.

Ventilation: Must meet local building codes.

Handling: Use extra care in handling shingles when the temperature is below 40°F.

Shingle Cutting: For best results ensure that all cutting devices are sharp and that when cutting shingles it is best to cut with a quick motion as you pull the roofing knife through the shingle.

Storage: Store in a covered ventilated area at a maximum temperature of 110°F. Bundles should be stacked flat. Protect shingles from weather when stored at the job site. Do not store near steam pipes, radiators, etc.

Fastener requirement: Use galvanized steel, stainless steel, or aluminum nails minimum 12-gauge shank with $\frac{3}{8}$ " diameter head. Owens Corning® Roofing recommends that fasteners comply with ASTM F1667. Check local building codes.

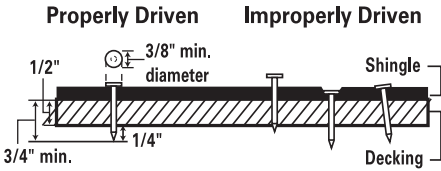

All Fasteners must penetrate at least $\frac{3}{4}$ " into the wood deck or completely through sheathing.

Notice: Owens Corning® Roofing recommends the use of nails as the preferred method of attaching shingles to wood decking or other nailable surface.

1. Specialty Eave Flashing:

Where required by code.

WeatherLock® underlayment or equivalent eave and flashing membrane applied to a point at least 24" beyond interior wall line. See manufacturer's installation instructions. See Fig. 1.

Fig. 1 Specialty Eave Flashing
Tapajuntas especial para aleros

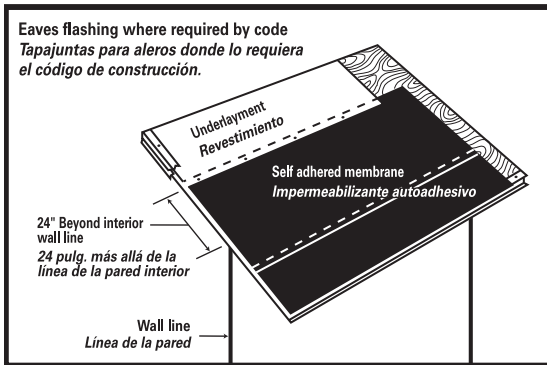

2. Underlayment:

Standard Slope (4" in 12" or more)

Application of underlayment, metal drip edges, and eaves flashing: See Fig. 2.

(A) Apply one layer of underlayment over metal drip edge at eaves. Use only enough fasteners to hold in place.

(B) Overlap successive courses 2". Overlap course ends 4". Side laps are to be staggered 6' apart.

(C) Apply metal drip edge over underlayment at rake.

Fig. 2 Underlayment Standard Slope
Pendiente estándar del revestimiento

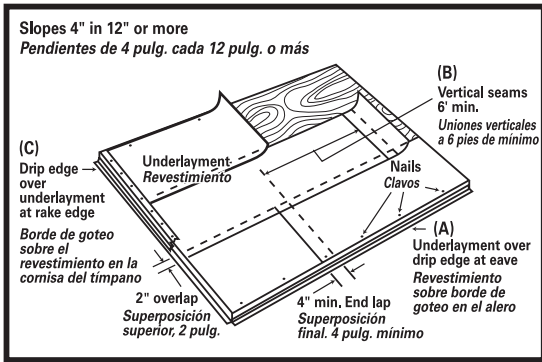

3. Underlayment:

Low Slope (2" in 12" to less than 4" in 12")

Application of roofing felt overlapped by 19 inches on each course. See Fig. 3.

- (A) Apply 19" starter strip of underlayment over metal drip edge at eaves. Use only enough fasteners to hold it in place.
 - (B) Use 36" strip of underlayment for remaining courses, overlapping each course 19". Side laps are to be staggered 6' apart.
 - (C) Apply metal drip edge over underlayment at rake.
- Or WeatherLock® self-adhered underlayment or equivalent with a standard overlap of 3 inches and metal drip edge. See Fig. 3A.

Fig. 3 Underlayment Low Slope
Pendiente baja del revestimiento

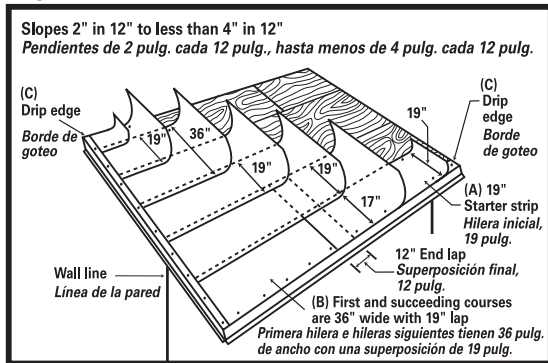
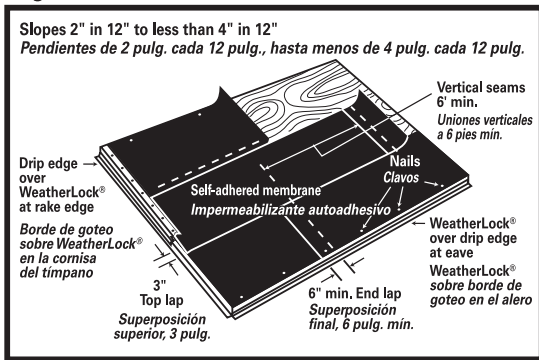

Fig. 3A Underlayment Low Slope
Pendiente baja del revestimiento



4. Shingle Fastening Pattern:

Standard Fastening Pattern.

Fasteners must be placed in the SureNail® fastening area. See Fig. 4.

Six Nail Fastening Pattern.

For 6 nail fastening pattern. See Fig. 4A.

Mansard or Steep Slope Fastening Pattern.

Place fasteners 6 1/8" from bottom edge to secure both layers of the shingle. Fasteners need to be located 6 1/8" above the butt edge of the shingle, regardless of whether they are in the granules or the SureNail® fastening area. See Fig. 4B.

Shingle Side View



REQUIRED: For slopes exceeding 60 degrees or 21" per foot, use six fasteners and four spots of asphalt cement per shingle. Apply immediately; one 1" diameter spot of asphalt cement **under** each shingle tab. Center asphalt roof cement 2" up from bottom edge of shingle tab.

Roof Cement where required must meet ASTM D4586 Type I or II (Asbestos Free).

Fig. 4 Standard Fastening Pattern
Esquema de instalación estándar

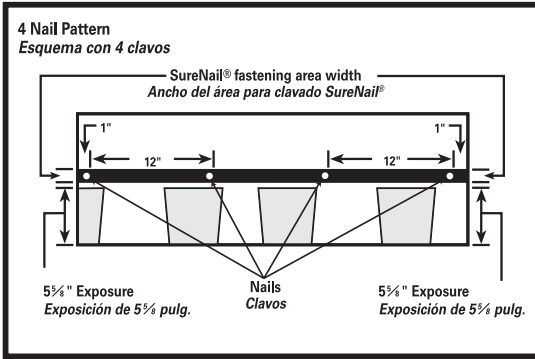

Fig. 4A Six Nail Fastening Pattern
Esquema de instalación con seis clavos

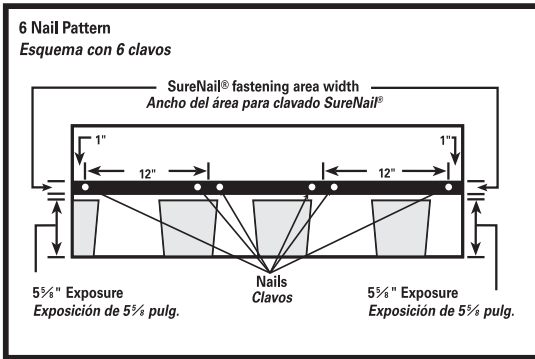
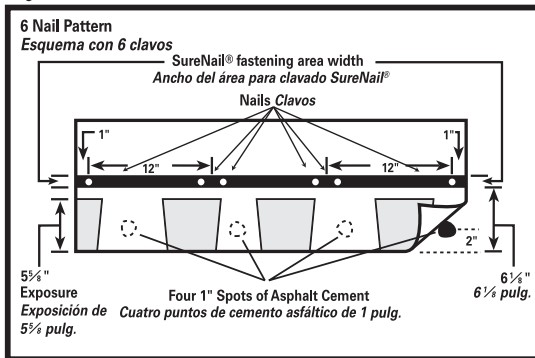

Fig. 4B Mansard or Steep Slope Fastening Pattern
Esquema de instalación en pendientes pronunciadas o mansardas



5. Shingle Application:

These shingles are applied with a 6 1/2" offset, with 5 5/8" exposure, over prepared roof deck, starting at the bottom of the roof and working across

and up. This will blend shingles from one bundle into the next and minimize any normal shade variation. Application with offsets of 4" or 5" are also acceptable.

Caution must be exercised to assure that end joints are no closer than 2" from fastener in the shingle below and that side laps are no less than 4" in succeeding courses. Refer to course application steps for specific instructions.

Starter Course:

Use starter roll or trim 5⁵/₈" from the starter course shingle. Trim 6¹/₂" off the rake of the starter course shingle and flush with the drip edge along the rake and eaves edge, and continue across the roof. Use 5 fasteners for each shingle, placed 2" to 3" up from eaves edge. *See Fig. 5. (If no drip edge is used, shingles must extend a minimum of 1/2" and no more than 1" from rake and eaves edge.)*

First Course:

Apply first course starting with the full shingle even with the starter course. *See Fig. 5A.*

Fasten securely according to fastening instructions. *See Fig. 4.*

Second Course:

Remove 6¹/₂" from the left end of this shingle and apply the remaining piece over and above the first course shingle and flush with edge of the first course with 5⁵/₈" exposure. *See Fig. 5B.*

Fasten securely according to fastening instructions. *See Fig. 4.*

Third Course:

Remove 13" from the left end of this shingle and apply the remaining piece over and above the second course shingle flush with edge of the second course with 5⁵/₈" exposure. *See Fig. 5C.*

Fasten securely according to fastening instructions. *See Fig. 4.*

Fourth Course:

Remove 19¹/₂" from the left end of this shingle and apply the remaining piece over and above the third course shingle and flush with edge of the third course with 5⁵/₈" exposure. *See Fig. 5D.*

Fasten securely according to fastening instructions. *See Fig. 4.*

Fifth Course:

Remove 26" from the left end of this shingle and apply the remaining piece over and above the fourth course shingle and flush with edge of the fourth course with 5⁵/₈" exposure. *See Fig. 5E.*

Fasten securely according to fastening instructions. *See Fig. 4.*

Sixth Course:

Remove 32½" from the left end of this shingle and apply the remaining piece over and above the fifth course shingle and flush with edge of the fifth course with 5⅝" exposure. See Fig. 5F.

Fasten securely according to fastening instructions. See Fig. 4.

Succeeding Courses:

For succeeding courses, repeat first through sixth course. See Fig. 5G.

6. Valley Construction:

Closed-Cut Valley See Fig. 6.

A closed-cut valley can be used as an alternative to woven or open valley and is applied as follows:

Lay a 36" wide valley liner of self-adhered membrane underlayment or equivalent. A 36" wide minimum 50 lb. roll roofing can also be used as a valley liner.

Lay all shingles on one side of valley and across center line of valley a minimum of 12". Fasten a minimum of 6" away from center line on each side of valley.

Strike a chalk line 2" from the center line of the unshingled side. Apply shingles on the unshingled side up to the chalk line and trim, taking care not to cut the underlying shingles. Clip upper corners of these shingles, cement and fasten.

Both woven and metal valleys are acceptable alternatives.

Fig. 6 Closed-Cut Valley Construction
Construcción del valle con corte cerrado

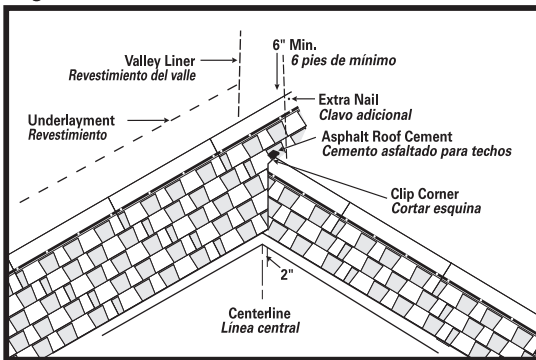

7. Step Flashing:

Use 10" long and 2" wider than expected exposure corrosion-resistant metal where roof planes butt against vertical sidewalls or chimneys. See Fig. 7. Check local building codes.

Fig. 7 Step Flashing
Tapajuntas escalonado

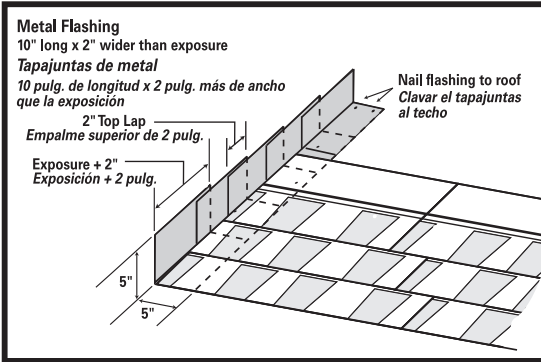

8. Hip & Ridge Application:

Use corresponding Owens Corning® Hip & Ridge shingles to best complement shingle color. Follow specific application instructions as printed on the Hip & Ridge shingle package. See Fig. 8.

Fig. 8 Hip & Ridge Application
Instalación de caballetes y cumbresras

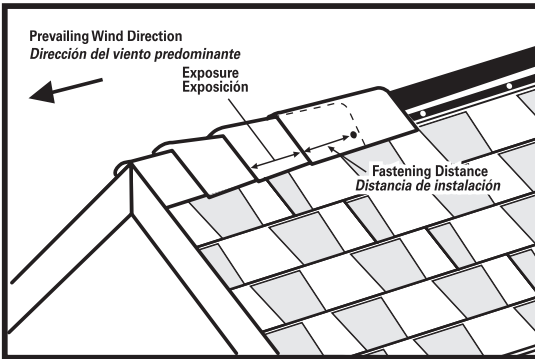

TruDefinition® WeatherGuard® HP Shingles

Application Instructions

The manufacturer will not be responsible for problems resulting from any deviation from the application instructions and the following precautions:

Precautionary Notes

- The existing roof covering must be removed before installing WeatherGuard® HP.
- Use of shingle-over ridge vent will affect the impact resistance classification of the WeatherGuard® HP Hip & Ridge; use off-ridge ventilation products as an alternative.
- Spacing between the decking at the ridge should not be more than 1/4" because it could affect the impact resistance classification.
- WeatherGuard® HP Hip & Ridge Shingles must be used.

CAUTION: Due to the aggressive nature of our shingle sealant strip, please note the following: To avoid shingles from sticking in hot sun, do not have the sealant strip make contact with various objects on the roof, until you are ready to nail the shingle in place.

Roof Top Loading: Lay shingle bundles flat. Do not bend over the ridge.

Roof Deck: ▪ 6" Minimum roof deck boards ▪ Minimum 3/8" plywood ▪ Minimum 7/16" OSB

Regardless of deck type used, the roofing installer must:

1. Install the deck material in strict compliance with the deck manufacturer's instructions.
2. Prevent the deck from getting wet before, during and after installation.

Ventilation: Must meet local building codes.

Handling: Use extra care in handling shingles when the temperature is below 40°F.

Storage: Store in a covered ventilated area at a maximum temperature of 110°F. Bundles should be stacked flat. Protect shingles from weather when stored at the job site. Do not store near steam pipes, radiators, etc.

Fastener requirement: Use galvanized steel, stainless steel, or aluminum nails minimum 12 gauge shank with 3/8" diameter head. Owens Corning® Roofing recommends that fasteners comply with ASTM F1667. Check local building codes.

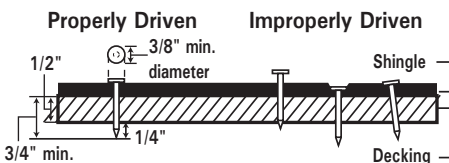

All Fasteners must penetrate at least $\frac{3}{4}$ " into the wood deck or completely through sheathing.

Notice: Owens Corning® Roofing recommends the use of nails as the preferred method of attaching shingles to wood decking or other nailable surface.

1. Specialty Eave Flashing:

Where required by code.

WeatherLock® underlayment or equivalent eave and flashing membrane applied to a point at least 24" beyond interior wall line.

See manufacturers installation instructions. See Fig. 1.

Fig. 1 Specialty Eave Flashing
Tapajuntas especial para aleros

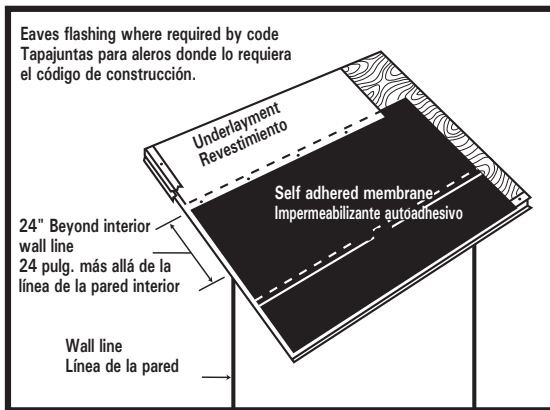

2. Underlayment:

Standard Slope (4" in 12" or more)

Application of underlayment, metal drip edges, and eaves flashing: See Fig. 2.

(A) Apply one layer of underlayment over metal drip edge at eaves. Use only enough fasteners to hold in place.

(B) Overlap successive courses 2". Overlap course ends 4". Side laps are to be staggered 6' apart.

(C) Apply metal drip edge over underlayment at rake.

Fig. 2 Underlayment Standard Slope
Revestimiento para pendientes estándar

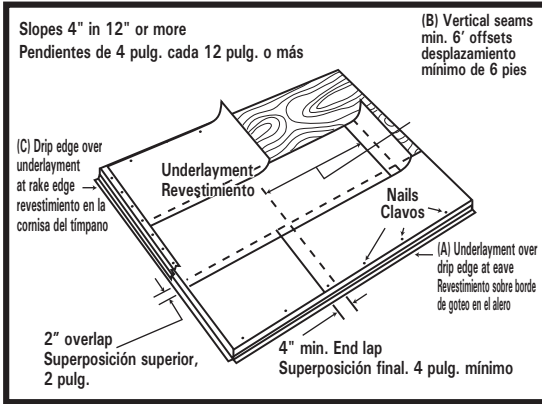

3. Underlayment:

Low Slope (2" in 12" to less than 4" in 12")

Application of underlayment, metal drip edges, and eaves flashing: *See Fig. 3.*

(A) Apply 19" starter strip of underlayment over metal drip edge at eaves. Use only enough fasteners to hold it in place.

(B) Use 36" strip of underlayment for remaining courses, overlapping each course 19". Side laps are to be staggered 6' apart.

(C) Apply metal drip edge over underlayment at rake.

Or WeatherLock® self-adhered underlayment or equivalent with a standard over lap of 3 inches and metal drip edge. *See Fig. 3A.*

Fig. 3 Underlayment Low Slope
Revestimiento para pendientes bajas

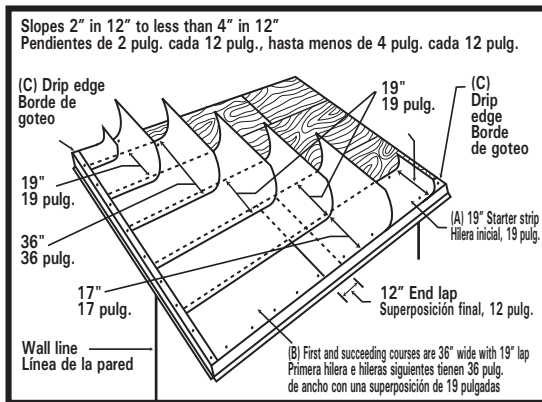
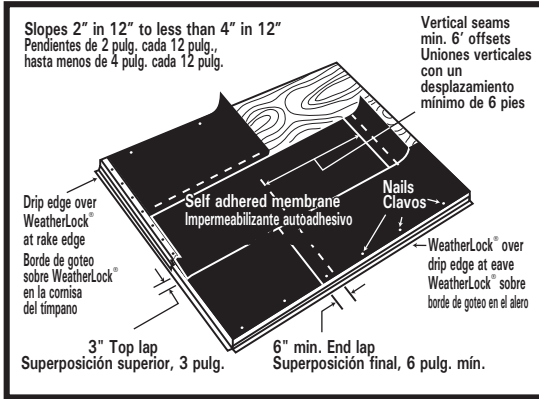

Fig. 3A Underlayment Low Slope Revestimiento para pendientes bajas



4. Shingle Fastening:

Nails **MUST** penetrate both layers of the shingle as shown in the diagram below.

Shingle Side View



Four Nail Pattern for 110 mph Use four fasteners placed $6\frac{1}{8}$ " from bottom edge to secure both layers of the shingle. See Fig. 4.

Six Nail Pattern for 130 mph Use six fasteners placed $6\frac{1}{8}$ " from bottom edge to secure both layers of the shingle. See Fig. 4A.

Mansard or Steep Slope Fastening Pattern. Place fasteners $6\frac{1}{8}$ " from bottom edge to secure both layers of the shingle. See Fig. 4B.

REQUIRED: For slopes exceeding 60 degrees or 21 inches per foot, use six fasteners and four spots of asphalt roof cement per shingle. Apply immediately; one 1" diameter spot of asphalt roof cement under each shingle tab. Center asphalt roof cement 2" up from bottom edge of shingle tab. See Fig. 4B.

Asphalt Roof Cement where required must meet ASTM D-4586 Type I or II (Asbestos Free).

Note: Please be aware that excessive amounts of asphalt roof cement could blister the shingle.

Fig. 4 Four Nail Pattern for 110 mph
 Esquema de instalación con 4 clavos para vientos de 110 mph

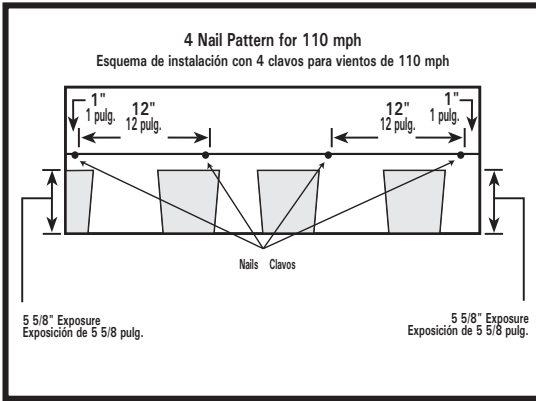

Fig. 4A Six Nail Pattern for 130 mph
 Esquema de instalación con 6 clavos para vientos de 130 mph

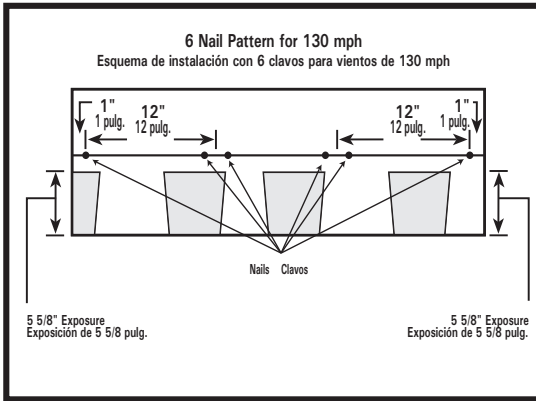
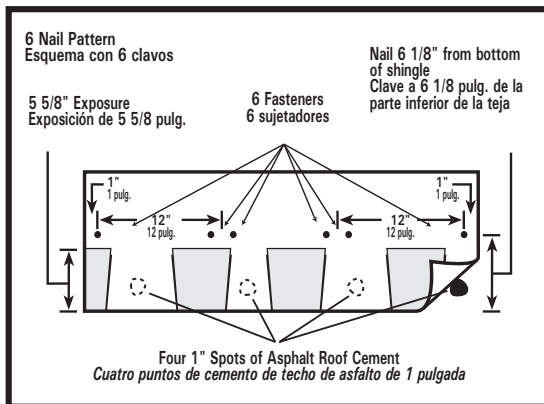

Fig. 4B Mansard or Steep Slope Fastening Pattern
 Esquema de instalación en pendientes pronunciadas o mansardas



5. Shingle Application:

These shingles are applied with a 6½" offset, with 5⅝" exposure, over prepared roof deck, starting at the bottom of the roof and working across and up. This will blend shingles from one bundle into the next and minimize any normal shade variation. Application with offsets of 4" or 8" are also acceptable.

Caution must be exercised to assure that end joints are no closer than 2" from fastener in the shingle below and that side laps are no less than 4" in succeeding courses. Refer to course application steps for specific instructions.

Fig. 5 Shingle Application
Instalación de tejas

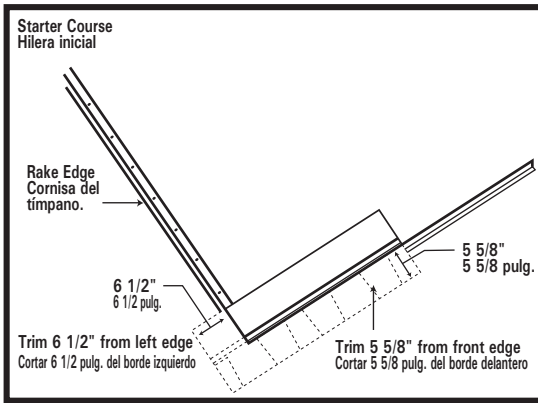
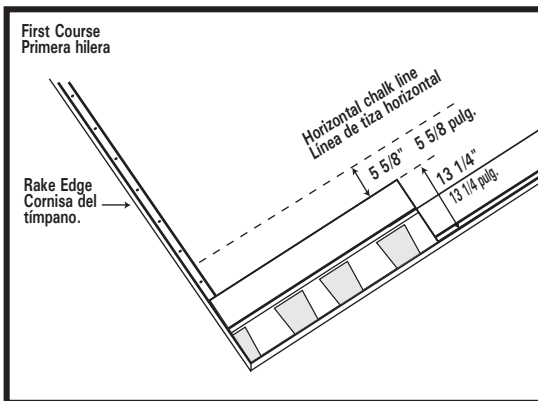

Fig. 5A Shingle Application
Instalación de tejas



Starter Course:

Use an Owens Corning® Roofing Starter product or trim 5⅝" from the starter course shingle. Trim 6½" off the rake of the starter course shingle and flush with the drip edge along the rake and eaves edge, and continue across the

roof. Use 5 fasteners for each shingle, placed 2" to 3" up from eaves edge. See Fig. 5. (If no drip edge is used, shingles must extend a minimum of 1/2" and no more than 1" from rake and eaves edge.)

First Course:

Apply first course starting with the full shingle even with the starter course. See Fig. 5A.

Fasten securely according to fastening instructions. See Fig. 4 or 4A.

Second Course:

Remove 6 1/2" from the left end of this shingle and apply the remaining piece over and above the first course shingle and flush with edge of the first course with 5 5/8" exposure. See Fig. 5B.

Fasten securely according to fastening instructions. See Fig. 4 or 4A.

Fig. 5B Shingle Application
Instalación de tejas

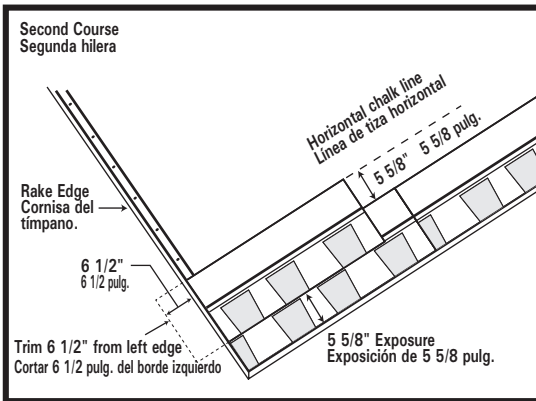

Third Course:

Remove 13" from the left end of this shingle and apply the remaining piece over and above the second course shingle flush with edge of the second course with 5 5/8" exposure. See Fig. 5C.

Fasten securely according to fastening instructions. See Fig. 4 or 4A.

Fig. 5C Shingle Application Instalación de tejas

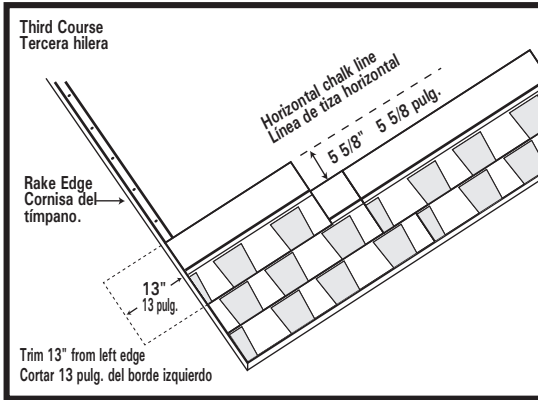

Fourth Course:

Remove 19½" from the left end of this shingle and apply the remaining piece over and above the third course shingle and flush with edge of the third course with 5⅝" exposure. See Fig. 5D.

Fasten securely according to fastening instructions. See Fig. 4 or 4A

Fifth Course:

Remove 26" from the left end of this shingle and apply the remaining piece over and above the fourth course shingle and flush with edge of the fourth course with 5⅝" exposure. See Fig. 5E.

Fasten securely according to fastening instructions. See Fig. 4 or 4A.

Fig. 5D Shingle Application Instalación de tejas

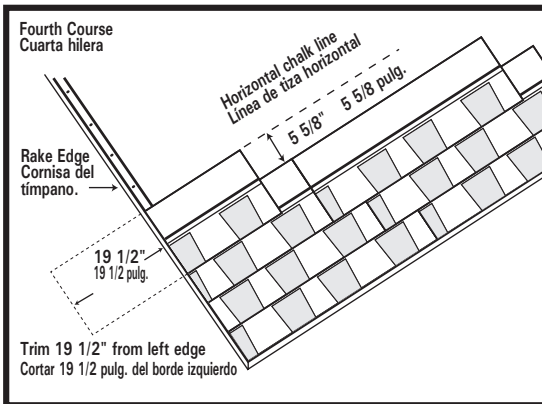

Fig. 5E Shingle Application
Instalación de tejas

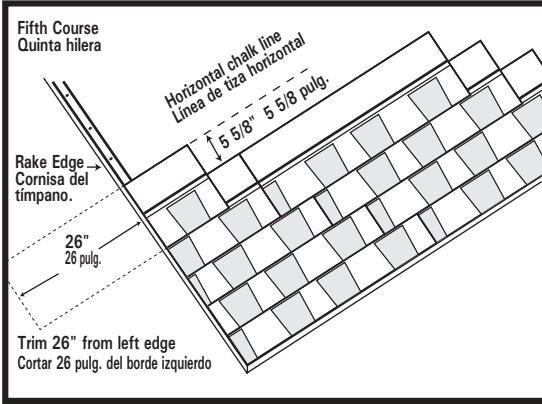
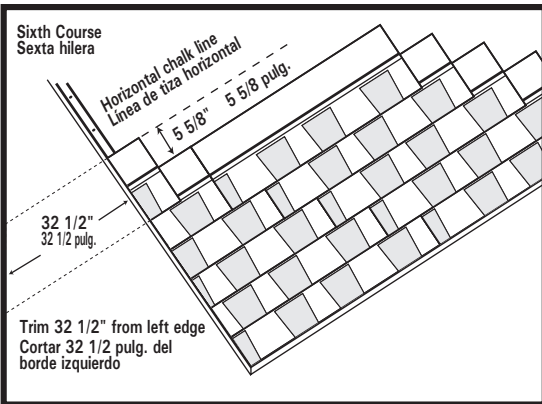

Fig. 5F Shingle Application
Instalación de tejas



Sixth Course:

Remove $32\frac{1}{2}$ " from the left end of this shingle and apply the remaining piece over and above the fifth course shingle and flush with edge of the fifth course with $5\frac{5}{8}$ " exposure. See Fig. 5F.

Fasten securely according to fastening instructions. See Fig. 4 or 4A.

Succeeding Courses:

For succeeding courses, repeat first through sixth course. See Fig. 5G.

Fig. 5G Shingle Application
Instalación de tejas

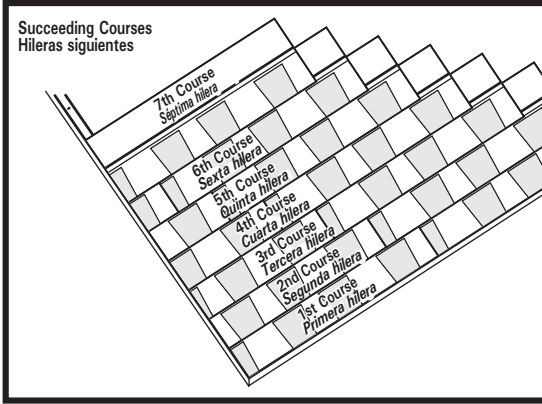

6. Valley Construction:

Closed-Cut Valley See Fig. 6.

A closed-cut valley can be used as an alternative to woven and open valley and is applied as follows: Lay a 36" wide valley liner of self adhered membrane underlayment or equivalent. A 36" wide minimum 50 lb. smooth surface roll roofing can also be used as a valley liner. Lay all shingles on one side of valley and across center line of valley a minimum of 12". Fasten a minimum of 6" away from center line on each side of valley. Strike a chalk line 2" from the center line of the unshingled side. Apply shingles on the unshingled side up to the chalk line and trim, taking care not to cut the underlying shingles. Clip upper corners of these shingles, cement and fasten. Both woven and metal valleys are acceptable alternatives.

Fig. 6 Closed-Cut Valley Construction
Construcción del valle con corte cerrado

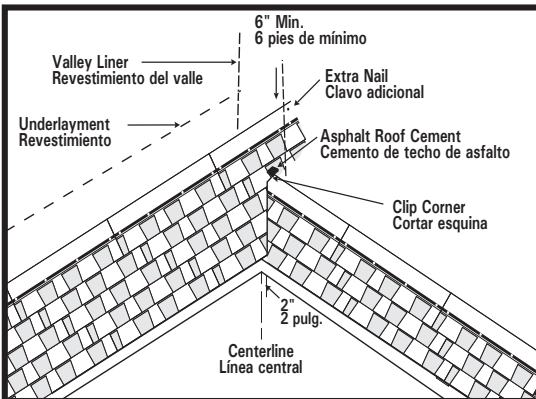

7. Step Flashing:

Use 10" long and 2" wider than expected exposure corrosion-resistant metal where roof planes butt against vertical sidewalls or chimneys. Check local building codes. See Fig. 7.

Fig. 7 Step Flashing
Tapajuntas escalonado

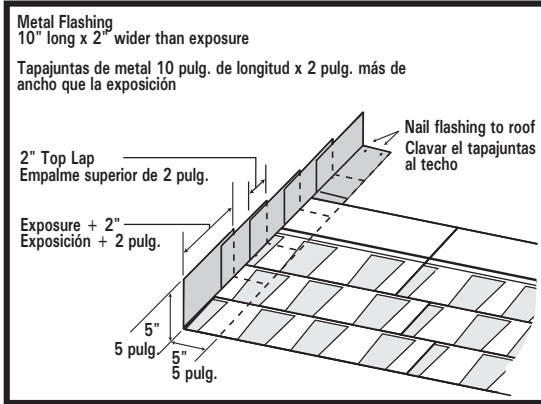

8. Hip & Ridge Application:

Use corresponding Owens Corning® WeatherGuard® HP Hip & Ridge shingles to best complement shingle color. Follow specific application instructions as printed on the hip & ridge shingle package. See Fig. 8.

Fig. 8 Hip & Ridge Application
Instalación de caballetes y cumbreras

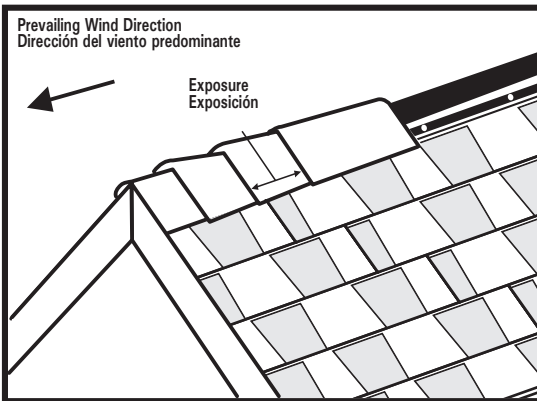

Oakridge® Shingles

Application Instructions

Before installing this product, check local building codes for their roofing requirements.

These shingles are designed for new or re-roofing work over any properly built and supported wood roof deck having adequate nail holding capacity and a smooth surface. Check local building codes.

Precautionary Note:

The manufacturer will not be responsible for problems resulting from any deviation from the recommended application instructions and the following precautions:

Roof Top Loading: Lay shingle bundles flat. Do not bend over the ridge.

Roof Deck: ▪ 6" Minimum roof deck boards ▪ Minimum $\frac{3}{8}$ " plywood ▪ Minimum $\frac{7}{16}$ " OSB

Regardless of deck type used, the roofing installer must:

1. Install the deck material in strict compliance with the deck manufacturer's instructions.
2. Prevent the deck from getting wet before, during and after installation.

Ventilation: Must meet local building codes.

Handling: Use extra care in handling shingles when the temperature is below 40°F.

Storage: Store in a covered ventilated area at a maximum temperature of 110°F. Bundles should be stacked flat. Protect shingles from weather when stored at the job site. Do not store near steam pipes, radiators, etc.

Fastener requirement: Use galvanized steel, stainless steel, or aluminum nails minimum 12 gauge shank with $\frac{3}{8}$ " diameter head. Owens Corning® Roofing recommends that fasteners comply with ASTM F 1667. Check local building codes.

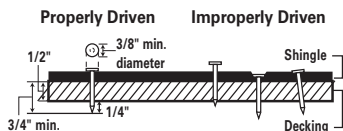

All Fasteners must penetrate at least $\frac{3}{4}$ " into the wood deck or completely through sheathing.

Notice: Owens Corning® Roofing recommends the use of nails as the preferred method of attaching shingles to wood decking or other nailable surface.

1. Specialty Eave Flashing:

Where required by code.

WeatherLock® underlayment or equivalent eave and flashing membrane applied to a point at least 24" beyond interior wall line. See manufacturer's installation instructions. See Fig. 1.

Fig. 1 Specialty Eave Flashing
Tapajuntas especial para aleros

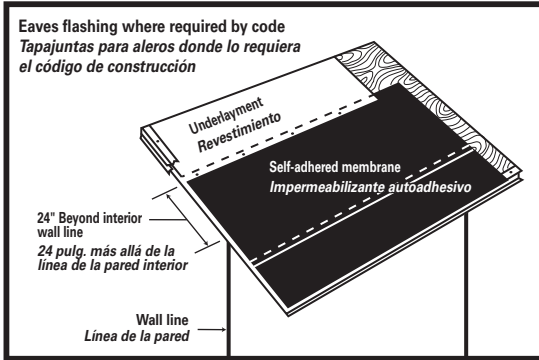

2. Underlayment:

Standard Slope (4" in 12" or more)

Application of underlayment, metal drip edges, and eaves flashing: See Fig. 2.

(A) Apply one layer of underlayment over metal drip edge at eaves. Use only enough fasteners to hold in place.

(B) Overlap successive courses 2". Overlap course ends 4". Side laps are to be staggered 6' apart.

(C) Apply metal drip edge over underlayment at rake.

Fig. 2 Underlayment Standard Slope
Pendiente estándar del revestimiento

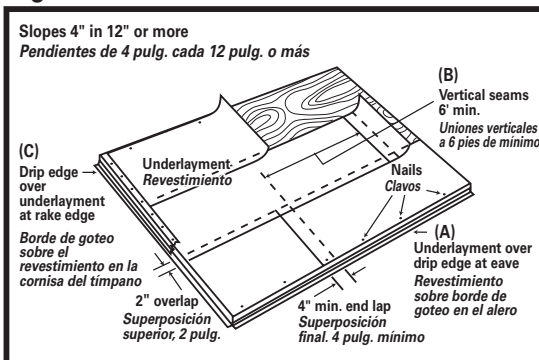

3. Underlayment:

Low Slope (2" in 12" to less than 4" in 12")

Application of underlayment, metal drip edges, and eaves flashing: See Fig. 3.

(A) Apply 19" starter strip of underlayment over metal drip edge at eaves. Use only enough fasteners to hold it in place.

(B) Use 36" strip of underlayment for remaining courses, overlapping each course 19". Side laps are to be staggered 6' apart.

(C) Apply metal drip edge over underlayment at rake.

Or WeatherLock® self-adhered underlayment or equivalent with a standard over lap of 3" and metal drip edge. See Fig. 3A.

Fig. 3 Underlayment Low Slope
Pendiente baja del revestimiento

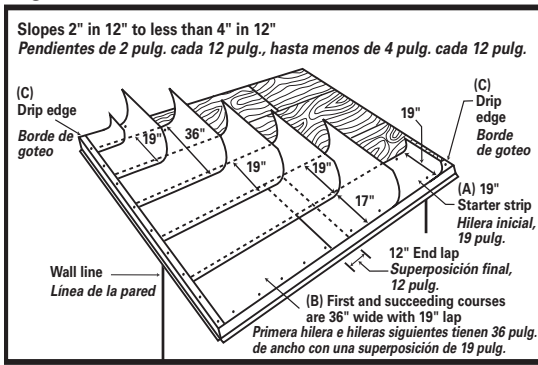
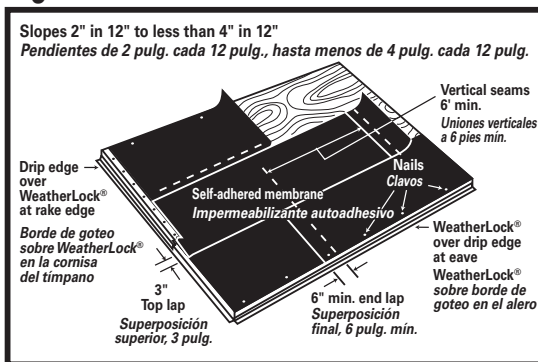

Fig. 3A Underlayment Low Slope
Pendiente baja del revestimiento



4. Shingle Fastening:

Place fasteners 6 1/8" from bottom edge of each shingle and 1" from each end.

Standard Pattern Use four fasteners. See Fig. 4.

Six Nail Pattern Use six fasteners. See Fig. 4A.

Mansard or Steep Slope Fastening Pattern. Place fasteners 6 $\frac{1}{8}$ " from bottom edge to secure both layers of the shingle. See Fig. 4B.

Shingle Side View



REQUIRED: For slopes exceeding 60 degrees or 21 inches per foot, use six fasteners and four spots of asphalt roof cement per shingle. Apply immediately; one 1" diameter spot of asphalt roof cement under each shingle tab. Center asphalt roof cement 2" up from bottom edge of shingle tab. See Fig. 4B.

Roof Cement where required must meet ASTM D4586 Type I or II (Asbestos Free).

Six nail fastening pattern is required for maximum wind warranty. In addition, Owens Corning® Starter Shingles are required along the eave and rake. (See Starter Shingle instructions for details.)

Fig. 4 Standard Fastening Pattern
Esquema de instalación estándar

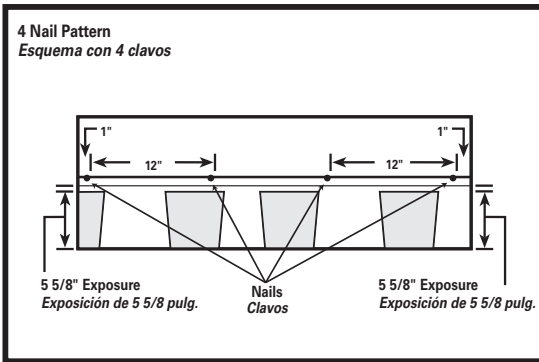

Fig. 4A Six Nail Fastening Pattern
Esquema de instalación con seis clavos

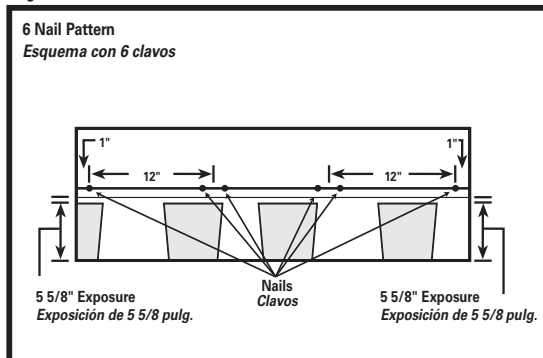
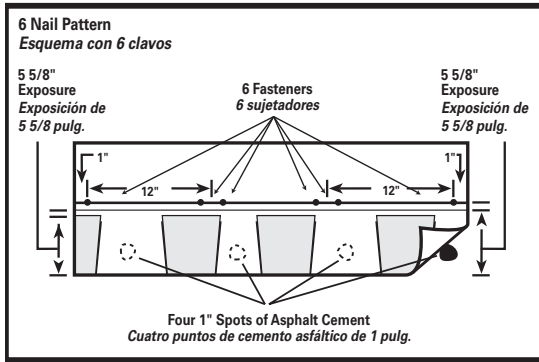

Fig. 4B Mansard or Steep Slope Fastening Pattern
Esquema de instalación en pendientes pronunciadas o mansardas



5. Shingle Application:

These shingles are applied with a 6 1/2" offset, with 5 5/8" exposure, over prepared roof deck, starting at the bottom of the roof and working across and up. This will blend shingles from one bundle into the next and minimize any normal shade variation. Application with offsets of 4" or 8" are also acceptable.

Caution must be exercised to assure that end joints are no closer than 2" from fastener in the shingle below and that side laps are no less than 4" in succeeding courses. Refer to course application steps for specific instructions.

Starter Course:

Use an Owens Corning® Starter shingle product or trim 5 5/8" from the starter course shingle. Trim 6 1/2" off the rake of the starter course shingle and flush with the drip edge along the rake and eaves edge, and continue across the roof. Use 5 fasteners for each shingle, placed 2" to 3" up from eaves edge. *See Fig. 5. (If no drip edge is used, shingles must extend a minimum of 1/2" and no more than 1" from rake and eaves edge.)*

Fig. 5 Shingle Application
Instalación de tejas

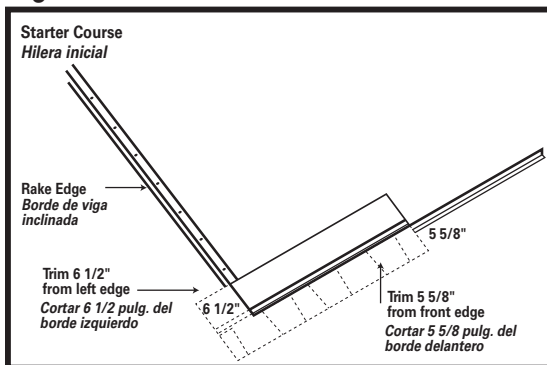

First Course:

Apply first course starting with the full shingle even with the starter course. See Fig. 5A. Fasten securely according to fastening instructions. See Fig. 4.

Second Course:

Remove 6 1/2" from the left end of this shingle and apply the remaining piece over and above the first course shingle and flush with edge of the first course with 5 5/8" exposure. See Fig. 5B. Fasten securely according to fastening instructions. See Fig. 4.

Fig. 5A Shingle Application
Instalación de tejas

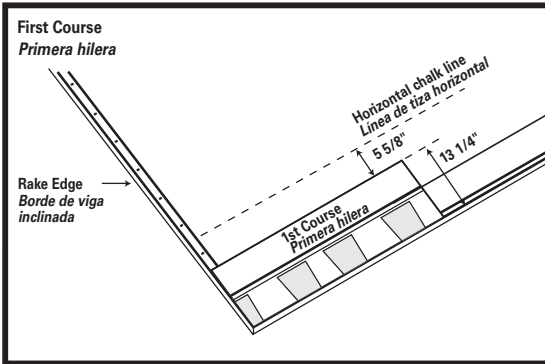

Fig. 5B Shingle Application
Instalación de tejas

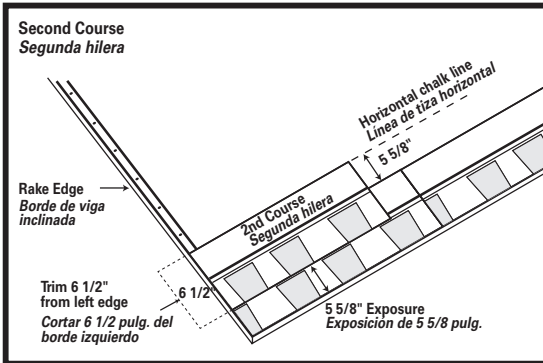
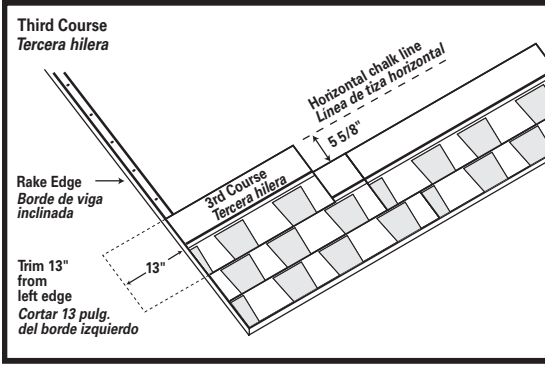

Fig. 5C Shingle Application
Instalación de tejas



Third Course:

Remove 13" from the left end of this shingle and apply the remaining piece over and above the second course shingle flush with edge of the second course with 5⁵/₈" exposure. See Fig. 5C. Fasten securely according to fastening instructions. See Fig. 4.

Fig. 5D Shingle Application
Instalación de tejas

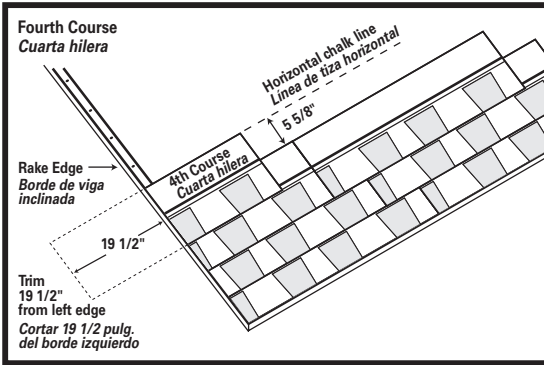

Fig. 5E Shingle Application
Instalación de tejas

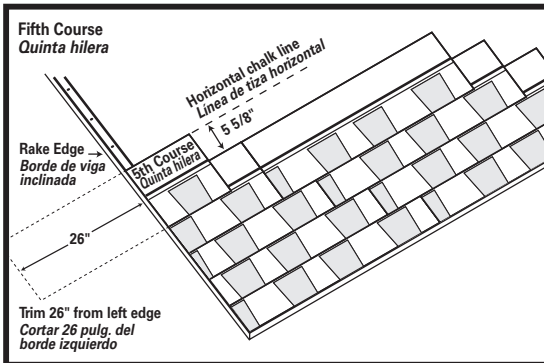

Fig. 5F Shingle Application
Instalación de tejas

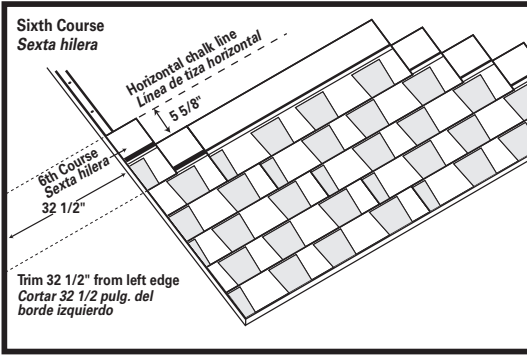
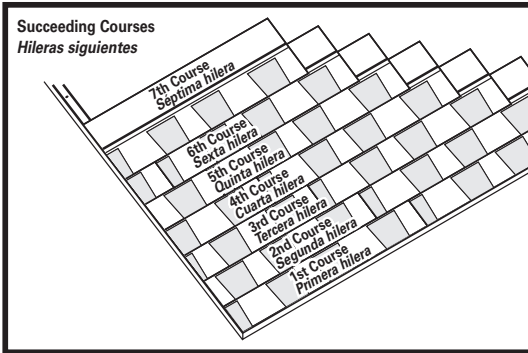

Fig. 5G Shingle Application
Instalación de tejas



Fourth Course:

Remove $19\frac{1}{2}"$ from the left end of this shingle and apply the remaining piece over and above the third course shingle and flush with edge of the third course with $5\frac{5}{8}"$ exposure. See Fig. 5D. Fasten securely according to fastening instructions. See Fig. 4.

Fifth Course:

Remove $26"$ from the left end of this shingle and apply the remaining piece over and above the fourth course shingle and flush with edge of the fourth course with $5\frac{5}{8}"$ exposure. See Fig. 5E. Fasten securely according to fastening instructions. See Fig. 4.

Sixth Course:

Remove $32\frac{1}{2}"$ from the left end of this shingle and apply the remaining piece over and above the fifth course shingle and flush with edge of the fifth course with $5\frac{5}{8}"$ exposure. See Fig. 5F. Fasten securely according to fastening instructions. See Fig. 4.

Succeeding Courses:

For succeeding courses, repeat first through sixth course. See Fig. 5G.

6. Valley Construction:

Closed-Cut Valley See Fig. 6.

A closed-cut valley can be used as an alternative to woven and open valley and is applied as follows:

Lay a 36" wide valley liner of self-adhered membrane underlayment or equivalent. A 36" wide minimum 50 lb. smooth surface roll roofing can also be used as a valley liner. Lay all shingles on one side of valley and across center line of valley a minimum of 12". Fasten a minimum of 6" away from center line on each side of valley. Strike a chalk line 2" from the center line of the unshingled side. Apply shingles on the unshingled side up to the chalk line and trim, taking care not to cut the underlying shingles. Clip upper corners of these shingles, cement and fasten. Both woven and metal valleys are acceptable alternatives.

Fig. 6 Closed-Cut Valley Construction
Construcción del valle con corte cerrado

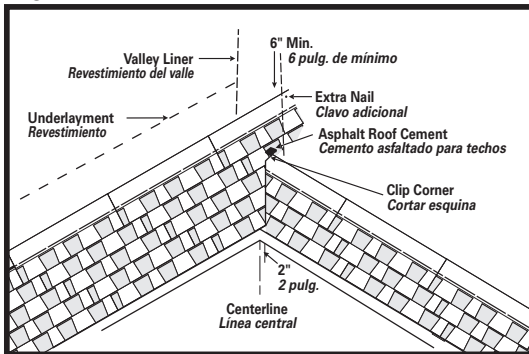

7. Step Flashing:

Use 10" long and 2" wider than expected exposure corrosion-resistant metal where roof planes butt against vertical sidewalls or chimneys. See Fig. 7.

Fig. 7 Step Flashing
Tapajuntas escalonado

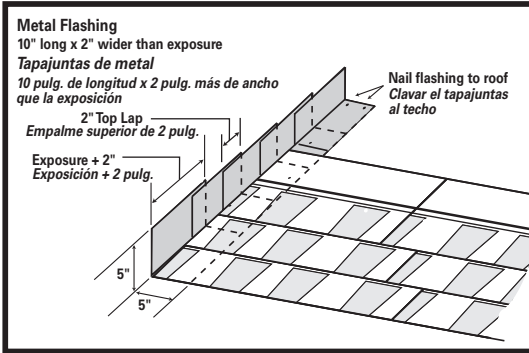

8. Hip & Ridge Application:

Use corresponding Owens Corning® Hip & Ridge shingles to best complement shingle color. Follow specific application instructions as printed on the Hip & Ridge shingle package. See Fig. 8.

Fig. 8 Hip & Ridge Application
Instalación de caballetes y cumbreras

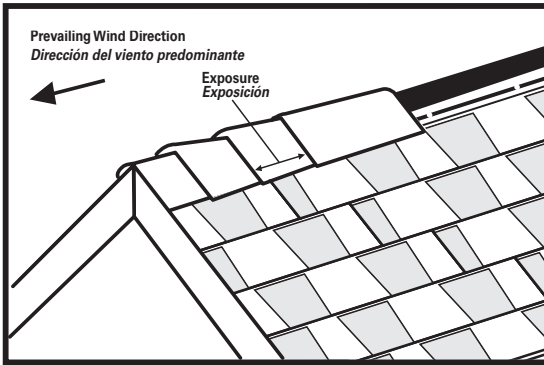

Supreme®/Classic® Shingles

Application Instructions

Before installing this product, check local building codes for their roofing requirements.

These shingles are designed for new or reroofing work over any properly built and supported wood roof deck having adequate nail holding capacity and a smooth surface. Check local building codes.

Precautionary Note:

The manufacturer will not be responsible for problems resulting from any deviation from the recommended application instructions and the following precautions:

Roof Top Loading: Lay shingle bundles flat. Do not bend over the ridge.

Roof Deck: ▪ 6" Minimum roof deck boards ▪ Minimum $\frac{3}{8}$ " plywood ▪ Minimum $\frac{7}{16}$ " OSB

Regardless of deck type used, the roofing installer must:

1. Install the deck material in strict compliance with the deck manufacturer's instructions.
2. Prevent the deck from getting wet before, during and after installation.

Ventilation: Must meet or exceed FHA Minimum Property Standards.

Handling: Use extra care in handling shingles when the temperature is below 40°F.

Storage: Store in a covered ventilated area at a maximum temperature of 110°F. Bundles should be stacked flat. Protect shingles from weather when stored at the job site. Do not store near steam pipes, radiators, etc.

Fastener requirement: Use galvanized steel, stainless steel, or aluminum nails minimum 12 gauge shank with $\frac{3}{8}$ " diameter head. Owens Corning® Roofing recommends that fasteners comply with ASTM F1667. Check local building codes

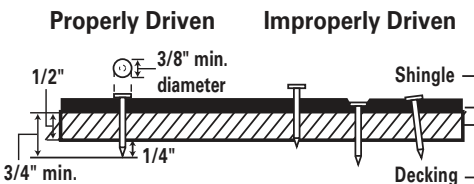

All Fasteners must penetrate at least $\frac{3}{4}$ " into the wood deck or completely through sheathing.

Notice: Owens Corning® Roofing recommends the use of nails as the preferred method of attaching shingles to wood decking or other nailable surface.

1. Specialty Eave Flashing:

Where required by code.

WeatherLock® underlayment or equivalent eave and flashing membrane applied to a point at least 24" beyond interior wall line. See manufacturer's installation instructions. See Fig. 1.

Fig. 1 Specialty Eave Flashing
Solins spéciaux

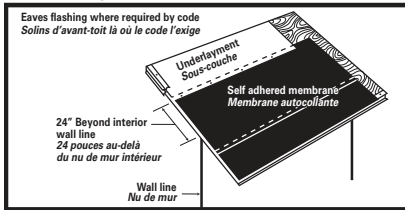

2. Underlayment:

Standard Slope (4" in 12" or more)

Application of underlayment, metal drip edges, and eaves flashing: See Fig. 2.

(A) Apply one layer of underlayment over metal drip edge at eaves. Use only enough fasteners to hold in place.

(B) Overlap successive courses 2". Overlap course ends 4". Side laps are to be staggered 6' apart.

(C) Apply metal drip edge over underlayment at rake.

Low Slope (2" in 12" to less than 4" in 12") Application of underlayment, metal drip edges, and eaves flashing: See Fig. 2A.

(A) Apply 19" starter strip of underlayment over metal drip edge at eaves. Use only enough fasteners to hold it in place.

(B) Use 36" strip of underlayment for remaining courses, overlapping each course 19". Side laps are to be staggered 6' apart.

(C) Apply metal drip edge over underlayment at rake.

Or WeatherLock® self-adhered underlayment or equivalent with a standard overlap of 3 inches and metal drip edge. See Fig. 2B.

Fig.2 Underlayment – Standard Slope
Sous-couche – pentes régulières

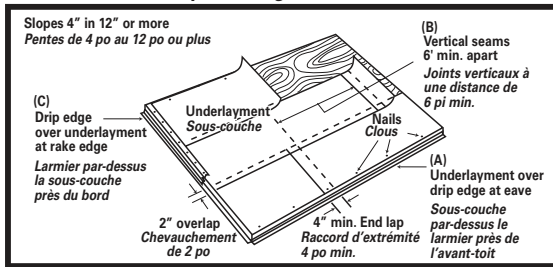

Fig.2A Underlayment – Low Slope
Sous-couche sur faibles pentes

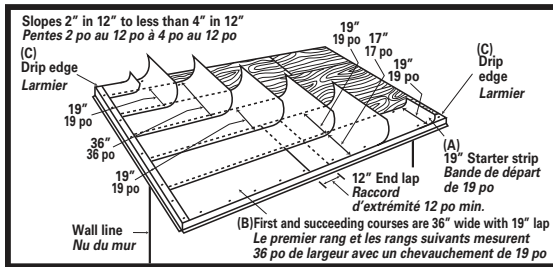
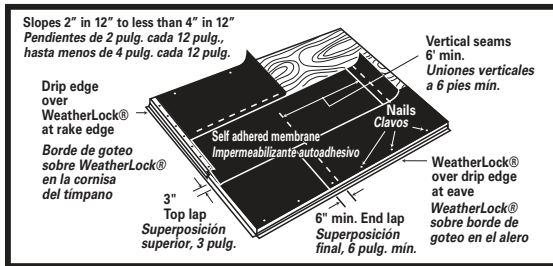

Fig.2B Underlayment – Low Slope
Sous-couche sur faibles pentes



3. Shingle Fastening:

Place fasteners 5/8" above the tab cut-out and below the adhesive strip. Fastening into the sealant strip interferes with sealing and contributes to blow-offs.

Standard Pattern

Use four fasteners. See Fig. 3

Fig.3 Standard Pattern
Pose régulière

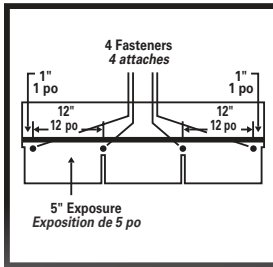
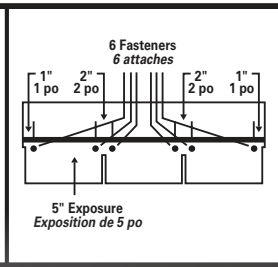

Fig.3A Six Nail Pattern
Pose à six clous



Six Nail Pattern

Use six fasteners. See Fig. 3A

Fig.3B Mansard or Steep Slope Pattern
Toit en mansarde ou à forte pente

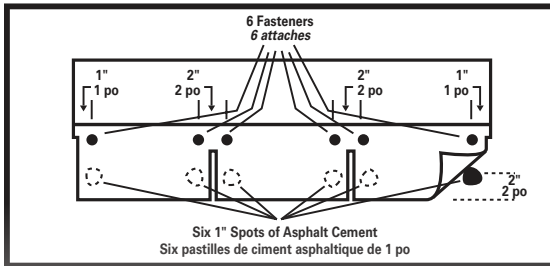

Mansard or Steep Slope Pattern

REQUIRED: For slopes exceeding 60 degrees or 21 inches per foot, use six fasteners and six (6) spots of asphalt roof cement per shingle. Apply immediately, one 1" diameter spot of asphalt roof cement under each corner shingle tab. Center asphalt roof cement 2" up from bottom edge of shingle tab. See Fig. 3B

Roof Cement where required must meet ASTM D4586 Type I or II (Asbestos Free)

4. Offset Measurement:

Apply shingles over properly prepared roof deck, starting at bottom of roof and working across and up. This will blend shingles from one bundle into the next and minimizes any normal shade variation. Supreme AR shingles are applied with a 6" offset. While a 6" offset is recommended, application with offsets of 4" or 5" are also acceptable. Caution must be exercised to assure that end joints are no closer than 2" from a fastener in the shingle below and that side laps are no less than 4" in succeeding courses. Refer to course applications steps for specific instructions. If racking application methods are used, the applicator must ensure that the proper number of fasteners is used, and **use shingles from several different bundles to reduce potential for color variation.** See Fig. 4.

Fig.4 Offset Measurement
Distance de décalage

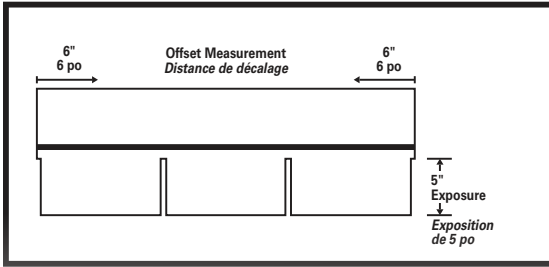

5. Shingle Application Starter Course See Fig. 5.

(A) Trim tabs off all starter course shingles so sealant can seal along the eave's edge. See Fig. 5.

Fig.5 Shingle Application
Installation des bardeaux

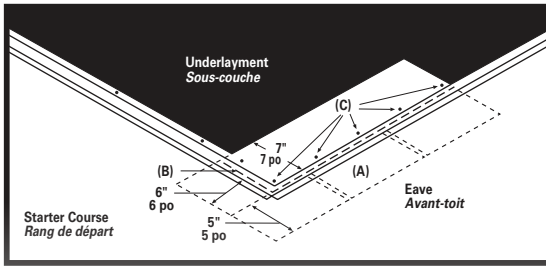

(B) Trim 6" off rake end of first shingle. Extend 3/8" beyond rake and eaves or flush with the drip edge, and fasten.

(C) Complete rest of starter course. Use 5 fasteners for each shingle, placed 2" - 3" up from the eaves edge.

First Course See Fig. 5A.

(D) Apply first course starting with a full shingle, even with the starter course. Fasten securely according to shingle fastening instructions above.

Note: Complete course with full shingles.

Second Course

(E) Begin second course by positioning first shingle 6" from the end of the underlying shingle, with the butt edge aligned with the top of the cutouts in the course below.

(F) Leave 5" exposure, fasten securely, and trim excess overhang at rake.

Note: Complete course with full shingles.

Third Course through Sixth Course

(G) Begin each subsequent course by positioning the first shingle 6" from the end of the underlying shingle, with the butt edge aligned with the top of the cutouts in the course below. Complete by repeating step (F).

Note: Complete each course with full shingles.

Seventh Course

(H) Apply seventh course starting with a full shingle. Leave 5" exposure and fasten securely. Complete by repeating step (F).

Note: Complete course with full shingles. For succeeding courses, repeat steps for second through seventh courses. See Fig. 5A.

Fig. 5A Shingle Application
Installation des bardeaux

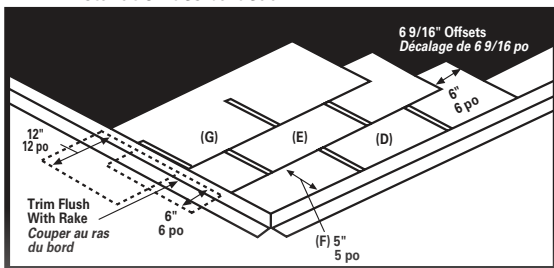

6. Valley Construction Closed-Cut Valley

 See Fig. 6.

A closed-cut valley can be used as an alternative to woven or open valley and is applied as follows: Lay a 36" wide valley liner of self-adhered membrane underlayment or equivalent. A 36" wide minimum 50 lb. roll roofing can also be used as a valley liner. Lay all shingles on one side of valley and across center line of valley a minimum of 12". Fasten a minimum of 6" away from center line on each side of valley. Strike a chalk line 2" from the center line of the unshingled side. Apply shingles on the unshingled side up to the chalk line and trim, taking care not to cut the underlying shingles. Clip upper corners of these shingles, cement and fasten. Both woven and metal valleys are acceptable alternatives.

Fig. 6 Closed Cut Valley Construction
Construction d'une noue fermée

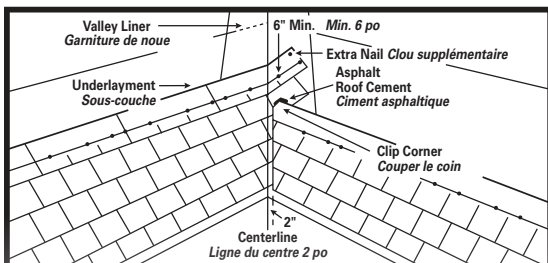

7. Step Flashing

Use 10" long and 2" wider than expected exposure corrosion-resistant metal where roof planes butt against vertical sidewalls or chimneys. See Fig. 7.

Fig.7 Step Flashing
Solins en gradins

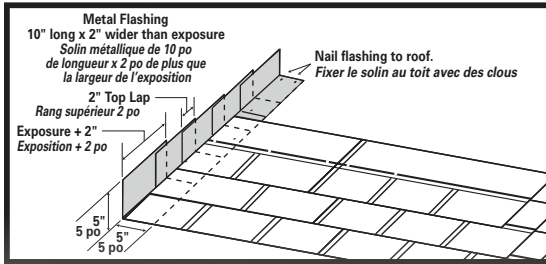

8. Hip and Ridge Application

Cut full Supreme AR shingles into three 12" x 12" hip and ridge shingles. Start hips at the eave and work up to ridge. Apply ridge only after hips have been applied, beginning on end of ridge opposite prevailing wind direction. Leave 5" exposure per shingle for hip and ridge application. Bend over the ridge; fasten on each side 6" from exposed end, 1" up from the edge. Cover exposed nails with asphalt cement. **For more information on hip and ridge application refer to Owens Corning's "How To Apply Hips & Ridges" (Pub. No. 5-RR-18491-A).** See Fig. 8.

Fig.8 Hip & Ridge
Installation sur les arêtes et les faîtes

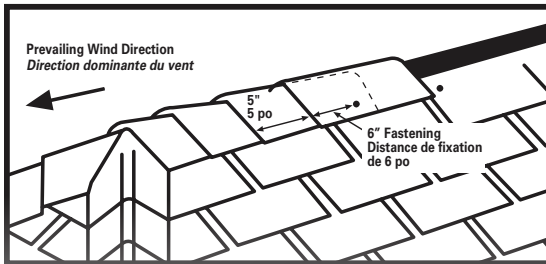

9. Reroofing with Shingles

If old asphalt shingles are to remain in place, nail down or cut away all loose, curled or lifted shingles. Sweep the surface clean of all loose debris just prior to applying the new roofing. Ensure proper size and length of fasteners. If roofing over old wood shingles, cut back the old shingles at eaves and rakes and apply wood edging strips. Some local building codes may require the use of a No. 30 asphalt saturated felt over the old wood shingles prior to reroofing. Consult local building code authorities. Surface must be smooth before shingles are installed. Make deck smooth by nailing down all loose and curled shingles, protruding nails, etc. Install beveled wood feathering strips, if necessary.

When roofing over existing shingles with a 5" tab exposure, the following procedure should be used for smoothest finished appearance and ease of alignment:

(A) Starter Course

Make starter shingles by removing the 5" tabs and cutting a 2" strip off the top of the shingles. Lay starter shingles so the top edge butts against the lower edge of the second course of the existing roof. Place the thermal sealing adhesive toward the eave edge. Secure with five fasteners evenly spaced per starter shingle placed 2" to 3" from the eaves edge. Complete the course.

(B) First Course

Trim 3" off the tops of all first course shingles. Lay them with their top edge butted against the bottom of the third course of the existing roof. Continue as instructed above.

(C) Second Course and Others

Use full-sized shingles and place them so their top edge is butted against the bottom edge of the next course of existing shingles. Continue as instructed above.

Note: Refer to ARMA Technical Bulletin regarding reroofing at <http://www.asphaltroofing.org/>

2" & 4" Selvage Mineral Surfaced Roll Roofing

Application Instructions for FIBERGLAS® Mineral Surfaced Roll Roofing

Not to be used as part of a Built-Up Roofing System. Apply over wood decks when incline is not less than 1" per foot. The deck must drain freely at all points.

General: It is suggested that roll roofing not be applied at temperatures below 50°F. When it is necessary to handle the material below this limit, it should be warmed before unrolling in order to avoid cracking.

The roll roofing should be cut into maximum 18' lengths and stacked in a pile on a smooth surface before application until they flatten out. This is important to prevent wrinkling after application.

Roof Deck: The roof deck shall be dry, firm, smooth, and constructed of a minimum $\frac{3}{8}$ " thick plywood, $\frac{7}{16}$ " oriented strand board (OSB) or dry well-seasoned lumber, nominal 1" thick, not over 6" in width. Boards shall be laid close together and securely nailed. If plywood or OSB is used it should be as recommended by the American Plywood Association, Underwriters Laboratories Inc.® or local building codes. Plywood and OSB sheathing must be spaced a minimum of $\frac{1}{8}$ " and maximum $\frac{1}{4}$ ".

Preparation of Roof Deck

New Construction: Install metal drip edges at eaves and rakes. Sweep roof deck clean of loose particles. Apply one layer of underlayment of #15 asphalt saturated felt over the entire roof surface. Lay in a horizontal manner lapping each course over the lower course 2"; and where ends join, lap them 4". Lay underlayment at least 6" over all hips, ridges and valleys.

Re-Roofing: Remove any slag or gravel. Cut open all blisters and buckles, and nail both edges to give a smooth surface; also nail edges of large cracks. Remove loose nails and drive into sound deck. Before beginning application of roofing, sweep roof deck clean of all loose particles and dirt.

Application

Nails: Use large head corrosion-resistant nails, 11- or 12-gauge, with heads at least $\frac{3}{8}$ " in diameter. Nails should be long enough to penetrate into wood deck at least $\frac{3}{4}$ ", or completely through plywood deck or OSB a minimum of $\frac{1}{8}$ ".

Concealed Nail Method

Edge Strips: Place 9" wide strips of roll roofing along the eaves and rakes, positioning them to overhang the deck $\frac{1}{4}$ " to $\frac{3}{8}$ ". Fasten the strips with rows of nails located 1" and 8" from the roof edge and spaced 4" on center in each row.

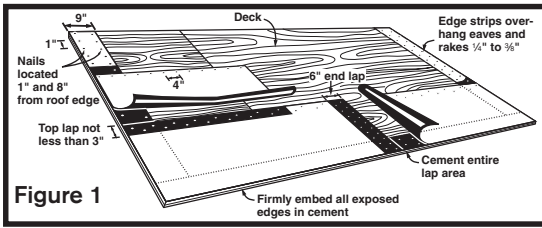

Figure 1

First Course: Apply the first course with a full-width strip of roll roofing so that its lower edge and ends are flush with the edge strips at the eaves and rakes. Fasten the upper edge with nails so that the next course will overlap them a minimum of 1". Lift the lower edge of the first course and cover the edge strips with lap cement. In cold weather, turn the course back carefully to avoid damaging the roofing material. Press the lower edge and rake ends of the first course firmly into the cement-covered edge strips. Work from one side of the sheet to the other to avoid wrinkling or bubbling.

End laps should be 6" wide and cemented over the full lap area with the recommended cement. Nail the underlying sheet in rows 1" and 5" from the end of the sheet with the nails spaced 4" on center and slightly staggered. End laps in succeeding courses must not line up with one another.

Second and Succeeding Courses: Apply the second course so that it overlaps the first course at least 2". Fasten the upper edge to the deck, cement the laps and finish installing the sheet in the same manner as the first course. Follow the same procedure for each successive course. Do not apply nails within 18" of the rake until cement has been applied to the edge strip and the overlying strip has been pressed down.

Hips and Ridges: Trim, butt and nail the sheets as they meet at a hip or ridge. Next, cut 12" x 36" strips from the roll roofing and bend them lengthwise to lay 6" on each side of the joint. Do not bend the strips in cold weather without first warming them. These will be used as "shingles" to cover the joint, each one overlapping the other by 6" as shown in Figure 2.

Start hips at the bottom and ridges at the end opposite the direction of the prevailing winds. To guide the installation, snap a chalk line 5½" from and parallel to the joint on both sides. Apply asphalt plastic cement evenly over the entire area between chalk lines from one side of the joint to the other. Fit the first folded strip over the joint and press it firmly into the cement, driving two nails 5½" from the edge of the end that will be lapped. Cover the 6" lap on this strip with lap cement. Then place the next strip over it. Nail and cement in the same manner as the first strip. Continue the same procedure until the hip or ridge is finished.

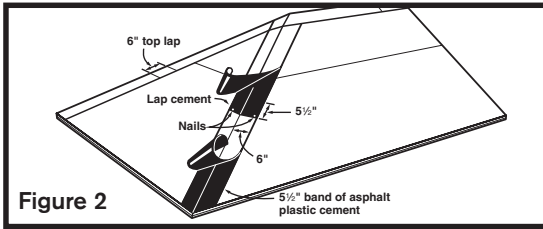

Applicable Standards

ASTM E 108, Class C UL 790, Class C

Owens Corning warrants that this product meets our specifications and is free from manufacturing defects when manufactured. Owens Corning shall have no liability for any product failures or damage caused by improper installation or any other cause other than manufacturing defects. Should the product prove to be other than as warranted, Owens Corning's sole and exclusive liability shall be limited, at the option of Owens Corning, to either replacement of the product or providing customer with a full refund of the original cost of the product.

THE FOREGOING CONSTITUTES OUR EXCLUSIVE WARRANTY, AND WE HEREBY DISCLAIM ALL OTHER WARRANTIES, WHETHER EXPRESSED OR IMPLIED, INCLUDING THE IMPLIED WARRANTIES OF MERCHANTABILITY AND FITNESS FOR A PARTICULAR PURPOSE. IN NO EVENT SHALL OWENS CORNING BE LIABLE TO CUSTOMER FOR INCIDENTAL, INDIRECT OR CONSEQUENTIAL DAMAGES.

OWENS CORNING SHALL NOT BE RESPONSIBLE FOR ANY DAMAGE, LOSS, COST, EXPENSE OR LIABILITY RELATING TO FAILURE TO FOLLOW THESE INSTRUCTIONS. FAILURE TO FOLLOW THESE INSTALLATION INSTRUCTIONS MAY AFFECT OWENS CORNING OBLIGATIONS UNDER THIS PRODUCT'S LIMITED WARRANTY.

DeckSeal Self-Adhered Roofing System

Components for Residential Slope

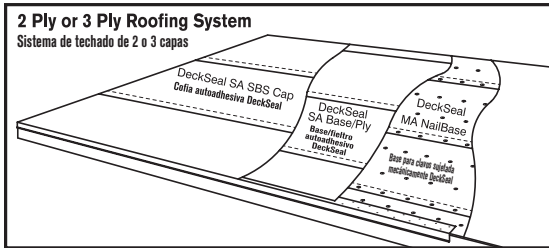

NOTE: If installing the DeckSeal MA NailBase under the DeckSeal SA SBS Cap see the following instructions for each of those components.

Owens Corning® DeckSeal MA NailBase

This product is to be used under Owens Corning® DeckSeal SA SBS Cap and should not be left exposed.

Do not use DeckSeal MA NailBase in a torch down application.

Storage

Owens Corning® DeckSeal MA NailBase should be stored at room temperature whenever possible. Do not store at temperatures above 90°F (32°C).

Precautionary Notes

Owens Corning Roofing recommends strict adherence to OSHA safety regulations.

DeckSeal MA NailBase is designed to be installed on roof slopes between 1/4:12 and 2:12 and is to be applied directly to an exterior grade of Plywood or OSB. Plywood must be minimum 15/32 inch and OSB minimum 7/16 inch. Check local codes. Owens Corning® DeckSeal SA SBS Cap is to be applied directly to Owens Corning® DeckSeal MA NailBase or DeckSeal SA Base/Ply.

- Apply only when the weather is dry and the ambient temperature is 45°F (7°C) and rising. Do not install when water in any form (i.e. rain, dew, ice, frost, snow) exists. All roof deck application areas must have positive drainage, continuous support, and be structurally sound to support the dead load requirements of the roofing system.
- Apply only over clean, dry, dust-free surfaces.
- Ensure installation of DeckSeal MA NailBase does not prevent or interfere with ventilation of the existing structure.

Failure to follow manufacturer's application instructions may void product warranty.

Plan the job so that the DeckSeal MA NailBase is covered by the DeckSeal SA

SBS Cap the same day.

Application

Step 1. Sweep the roof surface to remove any dust, dirt, or debris prior to starting installation.

Step 2. Cut the DeckSeal MA NailBase to manageable lengths. Allow the cut sheets to relax prior to installation. Failure to allow the sheets to relax may result in wrinkles in the finished surface.

Step 3. Initiate starter course:

- For a 2 ply (layer) system the starter course will always be $\frac{1}{2}$ of the roll width.
- For a 3 ply (layer) system the starter course will always be a $\frac{1}{3}$ of the roll width (approximately 12 inches) and cut from the DeckSeal MA NailBase roll. (Cutting on one of the 12" lines is approximately $\frac{1}{3}$ of the roll width).

The side lap seams of any 2 or 3 ply system layer should always be offset from the other layers.

Step 4. Lay the material flat on the roof aligned with the eaves or at the lowest point of the roof.

Step 5. Nail the starter course at 6 inches on center across the center of the sheet using 1 inch diameter metal cap nails. See Fig. 1

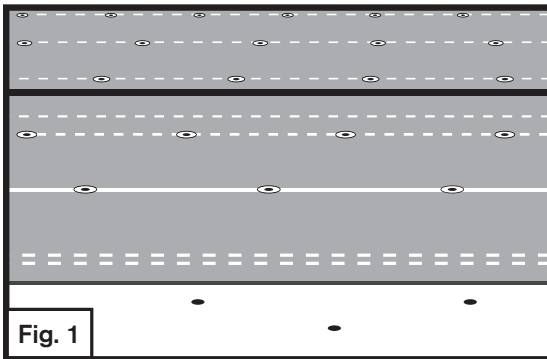

Do not nail along the edges at this time (edge metal will be added later), only in the center. If additional pieces are needed to complete the starter course, continue to install each piece overlapping the preceding piece by 6 inches. Nail in the middle of the 6 inch end lap at 6 inches on center.

Step 6. When the eaves starter sections are completed, position the next course (and all subsequent courses) by overlapping the previous course by 3 or 4 inches. Install metal cap nails at 6 inches on center in the 3 or 4 inch side lap.

All additional courses will require 2 rows of nails at 6 inches on center, evenly spaced vertically, and staggered down the center of the sheet. All end laps should be overlapped a minimum 6 inches. See Fig. 1

When installing each course stagger the end laps by 36 inches between courses.

Edge Metal Install

For 2 ply systems, the edge metal is installed directly over the base sheet. For a 3 ply system, the edge metal is installed over the second ply (layer).

1. The edge metal must be minimum 24 gauge galvanized steel or 0.040 inch formed aluminum, primed with either an asphaltic primer that meets ASTM D41 or a commercially available water-based acrylic primer.
2. The roof flange of the edge metal should be 3 or 4 inches wide.
3. Primed edge metal must be dry to the touch before membrane application.
4. Install the roof flange of the edge metal over the base sheet at the lowest point on the roof. Nail the edge metal 4 inches on center in a staggered pattern. See Fig. 1
5. Install a minimum 8 inch wide strip of self-adhered DeckSeal SA Base/Ply over the edge metal leaving 1/2 inch of edge metal exposed at the eaves.

NOTE: If installing the DeckSeal SA Base/Ply under DeckSeal SA SBS Cap, see the DeckSeal SA Base/Ply box for instructions for that component.

Owens Corning® DeckSeal SA Base/Ply

This product is to be used under Owens Corning® DeckSeal SA SBS Cap

Do not use Owens Corning® DeckSeal SA Base/Ply in a torch down application.

Storage

Owens Corning® DeckSeal SA Base/Ply self-adhered membrane should be stored at room temperature whenever possible. Do not store out of the box for prolonged periods, or in temperatures above 90°F (32°C). Do not remove the roll from the box until it is to be installed.

Precautionary Notes

Owens Corning Roofing recommends adherence to OSHA safety regulations.

DeckSeal SA Base/Ply is designed to be installed on roof slopes between 1/4:12 and 2:12 and is to be applied directly to an exterior grade of Plywood or OSB when used as a base sheet in a 2 ply system, or Owens Corning® DeckSeal MA NailBase when used as the second ply in a 3 ply system.

Note: When installing DeckSeal SA Base/Ply, existing Plywood and/or OSB must be primed with either an asphaltic primer that meets ASTM D41 or a commercially available water-based acrylic primer. New plywood and DeckSeal MA NailBase do not need to be primed.

Note: Any primed substrate must be fully dry prior to installation. Refer to manufacturer's recommendations. Plywood must be minimum 15/32 inch and OSB minimum 7/16 inch. Check local codes.

- Apply only when the weather is dry and the ambient temperature is 45°F (7°C) and rising. Do not install when water in any form (i.e. rain, dew, ice, frost, snow) exists. All roof deck application areas must have positive drainage, continuous support, and be structurally sound to support the dead load requirements of the roofing system.
- Apply only over clean, dry, dust-free surfaces.
- Ensure installation of DeckSeal SA Base/Ply does not prevent or interfere with ventilation of the existing structure.

Failure to follow manufacturer's application instructions may void product warranty.

Plan the job so that the DeckSeal SA Base/Ply is covered by the DeckSeal SA SBS Cap the same day.

Application

Step 1. Sweep the roof surface to remove any dust, dirt, or debris prior to starting installation.

Step 2. Cut the DeckSeal SA Base/Ply to manageable lengths. Allow the cut sheets to relax prior to installation. Failure to allow the sheets to relax may result in wrinkles in the finished surface.

Step 3. Initiate starter course:

- For a 2 ply (layer) system the starter course will always be 1/2 of the roll width.
- For a 3 ply (layer) system the starter course will always be 1/3 of the roll width. (Cutting on one of the 12" lay lines will leave approximately 1/3 of the roll width.) If using SA Base/Ply as a second layer of a 3 ply system, the starter course for that layer will be 2/3 of the roll width.

The side lap seams of any 2 or 3 ply system layer should always be offset from the other layers.

Step 4. There are several ways to remove the release liner from the DeckSeal SA Base/Ply. One method is as follows: Lay the material flat on the roof aligned with the eaves edge at the lowest point on the roof.

Step 5. Fold the aligned sheet back half way exposing the release liner. See Fig. 1

Step 6. Peel release film at a 45° angle in a constant motion, while firmly holding the half of the sheet that is in contact with the roof in place as the liner is removed. See Fig. 1

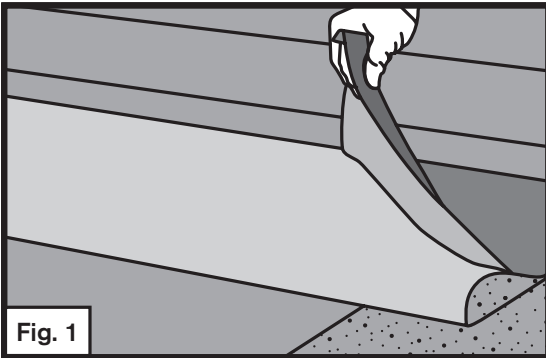

Step 7. Use hand or foot pressure to bond that portion of the sheet to the deck.

If the split release liner remains on the opposite half of the sheet, flip the opposite half back and remove the remaining release liner. Use hand or foot pressure to bond that portion of the sheet to the deck. See Fig. 2

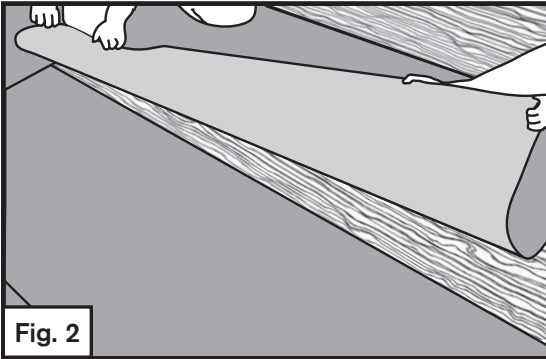

Step 8. If additional pieces are needed to complete the starter course, the end lap to be overlapped must be cut at 45° angles on the top and bottom corners. See Fig. 3

The top corner on the piece that is overlapping the previous piece must also be cut on the top corner at a 45° angle. See Fig. 3

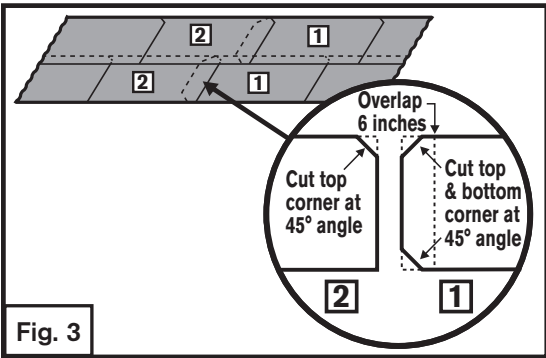

The overlap is to be 6 inches. Remove the release liner and adhere as with the previous sheet.

Step 9. Roll side laps and end laps firmly with a hand roller to ensure full adhesion. See Fig. 4

If necessary, hot air weld or apply modified asphalt flashing cement at 45° cuts or at end lap seams.

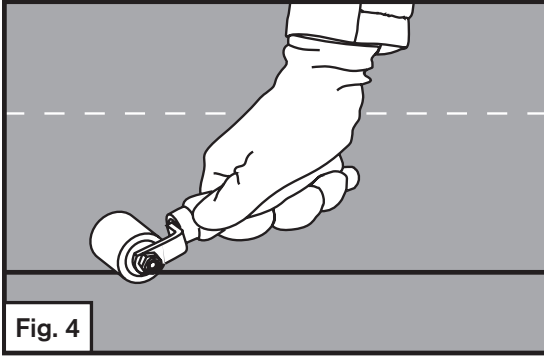

Step 10. As each course is completed, roll the course with an 80 pound linoleum roller. Start at the center and work outward to remove trapped air. See Fig. 5

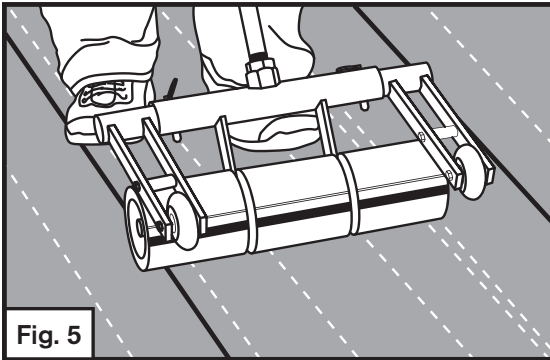

Step 11. When the eaves edge sections are completed, position the next course by overlapping the starter course by 3 to 4 inches.

When installing each subsequent course stagger the end laps by 36 inches between courses.

Step 12. One method to remove the release liner from a full sheet of DeckSeal SA Base/Ply is as follows:

- a) Position the sheet on the 3 or 4 inch overlap lay line and roll the bottom of the sheet half way back to expose the split release liner.
- b) Peel release film at a 45° angle in a constant motion, while firmly holding the half of the sheet that is in contact with the roof in place as the liner is removed.
- c) When the release film has been removed, carefully roll the sheet back down and press into place.

d) Roll the opposite half of the sheet back and remove the release liner using the same method as in step “b”.

e) Roll the sheet back down and press firmly into place.

Step 13. If additional pieces are needed to complete the course, the end lap corners are to be cut at a 45° angle as was done in Step 9. The overlaps are to be 6 inches.

Step 14. When the SA Base/Ply courses are complete roll the entire surface with an 80 pound linoleum roller.

Edge Metal Install

For 2 ply systems, the edge metal is installed directly over the base sheet. For a 3 ply system, the edge metal is installed over the second ply (layer).

1. The edge metal must be a minimum 24 gauge galvanized steel or 0.040 inch formed aluminum, primed with either an asphaltic primer that meets ASTM D41 or a commercially available water-based acrylic primer.
2. The roof flange of the edge metal should be 3 or 4 inches wide.
3. Primed edge metal must be dry to the touch before membrane application.
4. Install the roof flange of the edge metal over the base sheet at the lowest point on the roof. Nail the edge metal 4 inches on center in a staggered pattern. See Fig. 2
5. Install a minimum 8 inch wide strip of self-adhered DeckSeal SA Base/Ply over the edge metal leaving 1/2 inch of edge metal exposed at the eaves.

Owens Corning® DeckSeal SA SBS Cap

This product is not to be used in a torch down application.

Owens Corning® DeckSeal Low Slope products should be installed by a professional roofing contractor.

Storage

Owens Corning® DeckSeal SA SBS Cap should be stored at room temperature whenever possible. Do not store out of the box for prolonged periods, or in temperatures above 90°F (32°C). Do not remove the roll from the box until it is to be installed.

Precautionary Notes

Owens Corning Roofing recommends adherence to OSHA safety regulations.

DeckSeal SA SBS Cap is designed to be installed on roof slopes between 1/4:12 and 2:12 and is to be applied to an exterior grade of Plywood or OSB. Plywood must be minimum 15/32 inch and OSB must be minimum 7/16 inch. DeckSeal SA SBS Cap is to be applied directly to Owens Corning® DeckSeal MA NailBase or DeckSeal SA Base/Ply.

- Apply only when the weather is dry and the ambient temperature is 45°F

(7°C) and rising. Do not install when water in any form (i.e. rain, dew, ice, frost, snow) exists.

- All roof deck application areas must have positive drainage, continuous support, and be structurally sound to support the dead load requirements of the roofing system.
- Apply only over clean, dry, dust-free surfaces.
- Ensure installation of DeckSeal SA SBS Cap does not prevent or interfere with ventilation of the existing structure.

Failure to follow manufacturer's application instructions may void product warranty.

Application:

Step 1. Sweep the roof surface to remove any dust, dirt, or debris prior to starting installation.

Step 2. Cut the DeckSeal SA SBS Cap to manageable lengths. Allow the cut sheets to relax prior to installation. Failure to allow the sheets to relax may result in wrinkles in the finished surface.

Step 3. The DeckSeal SA SBS Cap has a release film covering the selvage edge. The cap sheet should be installed with the selvage edge away from the eaves edge. The DeckSeal SA SBS Cap starter course is always installed full width.

Step 4. Lay the material flat on the roof aligned with the eaves edge at the lowest point on the roof.

One method to remove the release liner from the sheet of DeckSeal SA SBS Cap is as follows:

Step 5. Fold the aligned sheet back half way, exposing the split release liner. See Fig. 1

Step 6. Remove release liner at a 45° angle in a constant motion, while firmly holding the half of the sheet that is in contact with the roof in place as the liner is removed. See Fig. 1

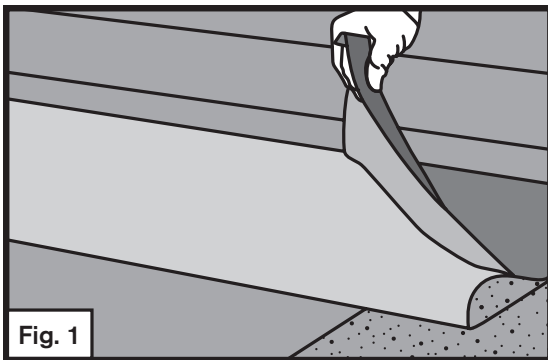
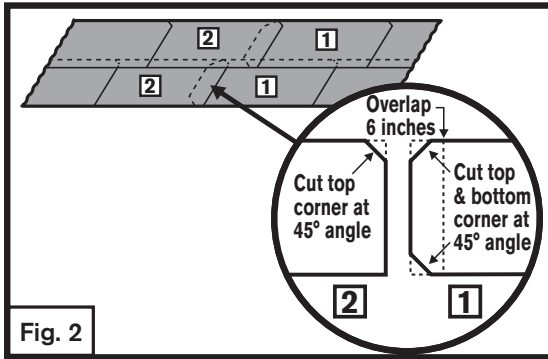

Fig. 1

Now that the release liner is removed, roll the sheet and press firmly into place.

Now roll the opposite half of the sheet back and remove the release liner using the same method as above.

If additional pieces are needed to complete the starter course, the end lap to be overlapped must be cut at 45° angles on the top and bottom corners. See Fig. 2. The top corner on the piece that is overlapping the previous piece must also be cut on the top corner at a 45° angle. See Fig. 2.



The overlap is to be 6 inches. Remove the release liner and adhere as with the previous sheet.

Remove the side lap selvage edge release film on the area to be overlapped.

Do not remove the remaining release film covering the side lap selvage edge at this time.

Step 7. The end of each roll of DeckSeal SA SBS Cap has a factory end lap selvage edge covered with a release film. Remove the end lap release film and press the overlapping sheet into place. See Fig. 3.

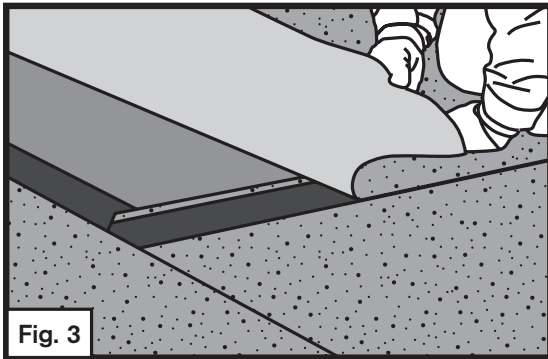

If necessary, during cool weather, hot air weld or apply modified asphalt flashing cement at all 45° cuts or at end lap seams and T-joints.

Where there is no factory selvage edge for end laps, the following methods can be used.

HOT AIR WELDING

The area between the granular surface and self-adhesive backing can be heated with a hot air welding tool and rolled with a hand roller. This will ensure a water tight seal to the end laps. See Fig. 4.

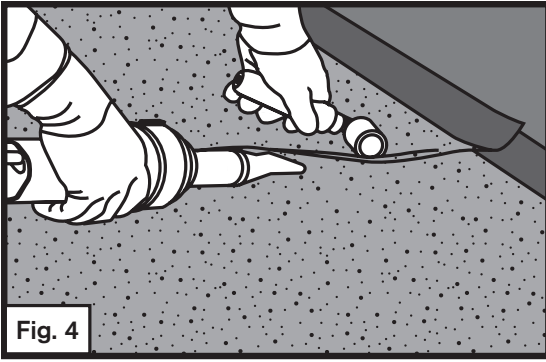

MODIFIED ROOF CEMENT

In lieu of hot air welding, the top layer can be set in a thin layer of modified asphalt flashing cement that is at least 6 inches wide and approximately 1/8 inch thick. Take care to prevent roof cement from oozing onto exposed area. If this should occur, sprinkle loose granules on the exposed asphalt immediately. See Fig. 5

End laps must be a 6 inch minimum and fully adhered.

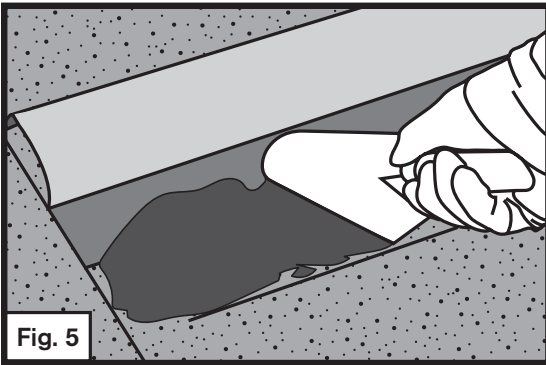

Step 8. Press each sheet into place with firm, even pressure.

Step 9. Roll edges and all lap seams firmly with a hand roller to ensure full adhesion. After each course is completed roll the course with an 80 pound linoleum roller. Start at the center and work outward to remove trapped air.

Step 10. For the succeeding course, position the next sheet by completely overlapping the selvage edge of the previous sheet. See Fig. 6

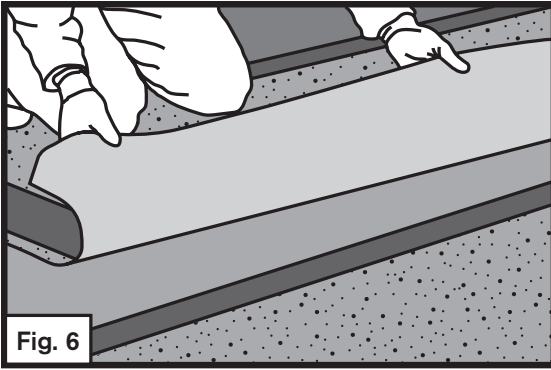

Fig. 6

Be sure to offset end laps on each subsequent course a minimum of 36 inches. Only remove enough of the selvage edge release film on the preceding roll to complete each section of the install. Removing more film than is necessary may cause the exposed adhesive to stick to the release liner of subsequent sheets during alignment. See Fig. 7

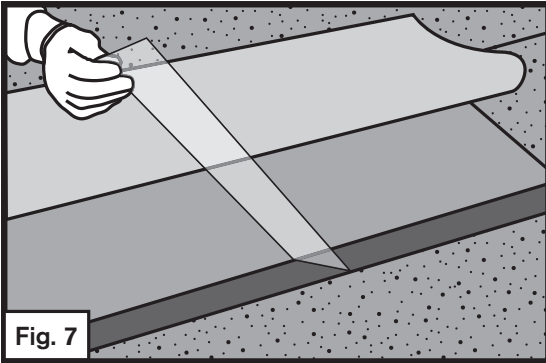

Fig. 7

Remove release liner on succeeding course as previously described.

Step 11. After adhering rolls, it is required that uniform pressure be applied to the entire deck area using a 80 pound linoleum roller. Care must be taken to prevent injury when rolling, especially on sloped surfaces.

WeatherLock® Self-Sealing Ice & Water Barrier

For sloped residential buildings with wood decks

WeatherLock® Self-Sealing Ice & Water Barrier installed between the roof deck and asphalt shingles, wood shakes, or slate roof assemblies helps to lock out damage from wind-driven rain and ice damming. This exclusive Owens Corning® Roofing composition is engineered to lay flat and remain dimensionally stable. Rain. Shine. Or ice.



WeatherLock Ice & Water Barrier helps prevent costly damage from ice and water seeping through the roof and roof deck, such as:

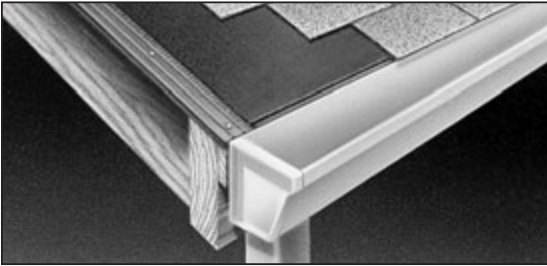

Ice Damming

Continual thawing and refreezing of melting snow or the backup of frozen slush in gutters can cause water leakage.

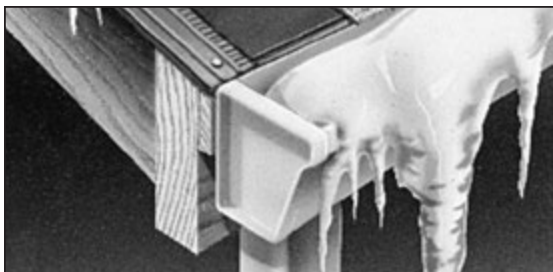

Wind-Driven Rain

Hard, wind-driven rain can cause backup in gutters and drains.

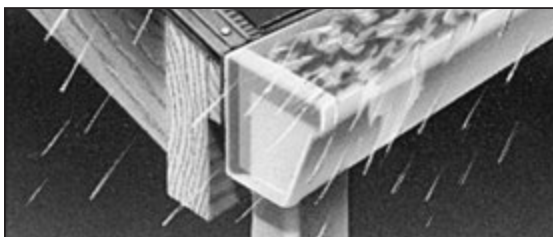

Caution

Read and understand all instructions and precautions before applying *WeatherLock Ice & Water Barrier*.

Deck Preparation

1. Owens Corning® *WeatherLock* G, Flex, Mat and Cold Climate should be applied on roofs having slopes of 2" rise minimum in 12" run or greater.
2. It can be applied on new construction or when re-roofing, provided existing shingles have been removed. Remove all old roofing down to the deck, or in new construction, apply over the new deck.
3. Sweep the deck surface to remove dirt and debris. The deck must be clean and dry before applying *WeatherLock* products. Replace any damaged or rotted deck boards. No primer is necessary.

Eave Preparation

4. *WeatherLock* products should be applied over the metal drip edge at the eave; ensure metal drip edge is nailed properly.
5. *WeatherLock* products should be applied under the drip edge at the rake.

Installation

6. Unroll *WeatherLock* underlayment and cut into 10'–20' lengths, depending on length of job. Allow to relax for 3–5 minutes before installing.
7. Reroll each portion. Remove the first two feet of the release backer and press the product into place. While supporting the roll with one hand, remove the release backer with the other hand and press or roll into place. *WeatherLock* products may be secured with nails (18" on center) on steeper slopes or as needed.

8. Along a valley, *WeatherLock* underlayment can be installed in valley as a valley liner. For maximum protection, the roll width should remain intact and extend 18" on either side of the valley. Peel back the poly backer sheet and press *WeatherLock* underlayment into place working from the center of the valley or ridge outward in each direction. Always apply valleys starting at the low point and work upwards. If an overlap is needed, be sure to overlap the previous piece by 3". *WeatherLock* products should be applied in valleys before doing eave applications with membranes.
9. *WeatherLock* products should extend from the eaves to a point 24" inside the exterior wall. This will place the *WeatherLock* products well above the maximum ice dam buildup line in most areas. Consult local building code for specific requirements.
10. If a second course is needed, overlap the second course onto the first course, 3" to the marked ply line. The lap area must be firmly hand rolled to ensure a watertight bond. Continue this same application procedure for additional courses, as needed. Adhesive is not required.
 - 10a. If installing *WeatherLock* G underlayment: If a second course is needed, overlap the second course 3" onto the top of the first course taped selvedge edge. The lap area must be firmly hand rolled to ensure a watertight bond.
11. Extra courses should be installed using the same application instructions as described in sections 1 and 2. Extra courses may be installed with nails (18" on center) as needed and depending on the slope of the roof. Use hand pressure or a roller to smooth the lapped area to insure good adhesion.
12. Overlap at least 6" when the ends of two rolls meet.
13. Cover *WeatherLock* product with finish roofing material. Do not allow *WeatherLock* underlayment to remain uncovered more than 30 days. Prolonged exposure to wind, sun and weather will adversely affect this product's installation and performance.

Precautions

1. *WeatherLock* products should be installed by a professional roofing contractor. *WeatherLock* underlayment is designed to be covered by asphalt shingles, wood shakes or quarry slate roof assemblies. Protection from sunlight is required to assure its long-term performance.
2. *WeatherLock* underlayment is a moisture and vapor barrier. Since ice buildup is partially a function of ventilation, the spaces under the covered deck area and the attic space must be ventilated in accordance with FHA Minimum Property Standards and local building codes.
3. *WeatherLock* underlayment is intended for exterior application only.
4. Apply *WeatherLock* product directly to the wood deck. Do not apply shingle underlayment beneath *WeatherLock* product.
5. Shingles should not be installed over wrinkled or buckled *WeatherLock* product.

6. Use extreme caution when installing *WeatherLock* products. The *WeatherLock* underlayment surface is slippery even when dry. Use of fall protection is highly recommended. Consult OSHA for guidelines on fall protection (20 CFR 1926.500).
7. For best results, apply *WeatherLock* underlayment when the air temperature is over 40°F (5°C) but below 100°F (38°C). When temperatures are under 40°F, *WeatherLock* underlayment will not fully adhere until warmer temperatures. Store at room temperatures prior to installing product in cold weather. If applied in temperatures above 100°F (38°C), it may become difficult to remove the release poly backing. If this situation should occur, move product into a shaded area until the *WeatherLock* product is cool. Once cooled, the release poly backing can be easily removed.
8. Store *WeatherLock* product in a dry, well-ventilated area. Stand *WeatherLock* product upright. Do not store at 90°F (32°C) or warmer for extended periods of time. When applying *WeatherLock* product, always follow local building codes and the shingle manufacturer's instructions for installation of its product.

WeatherLock® Flex Flexible Self-Sealing Ice & Water Barrier

For sloped residential buildings with wood decks

WeatherLock® underlayment installed between the roof deck and asphalt shingles, cedar shakes, concrete tile or slate roofing helps to lock out damage from wind-driven rain and ice damming. This exclusive Owens Corning composition of polyethylene, styrene-butadiene-styrene modified asphalt and a Fiberglas® mat for added reinforcement means *WeatherLock* underlayment can lie flat and remain dimensionally stable. Rain. Shine. Or ice.



WeatherLock underlayment helps to prevent costly damage from ice and water seeping through the roof and roof deck.

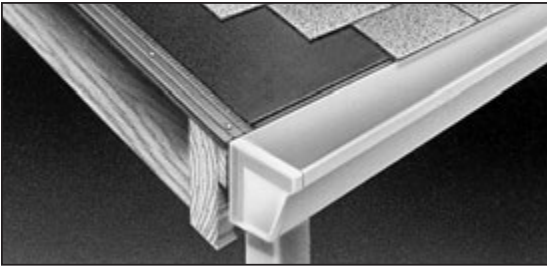

Ice Damming

Continual thawing and refreezing of melting snow or the backup of frozen slush in gutters can cause water leakage.

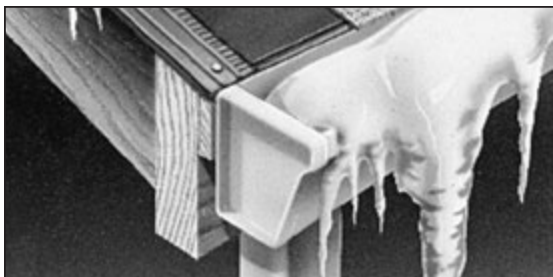

Wind-Driven Rain

Hard, wind-driven rain can cause backup in gutters and drains.

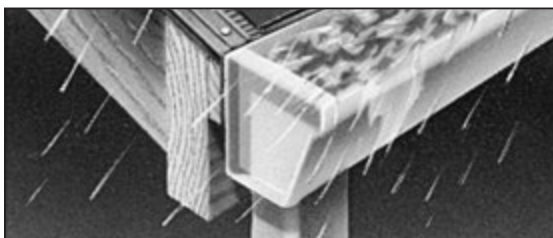

Caution

Read and understand all instructions and precautions before applying *WeatherLock Flex Flexible Self-Sealing Ice & Water Barrier*.

Deck Preparation

1. Owens Corning® *WeatherLock Flex Flexible Self-Sealing Ice & Water Barrier* should be applied on roofs having slopes of 1" rise in 12" run or greater.

It can be applied on new construction or when reroofing, provided existing shingles have been removed. Remove all old roofing down to the deck, or, in new construction, apply over the new deck.

Sweep the deck surface to remove dirt and debris. The deck must be clean, smooth and dry before applying *WeatherLock Flex*. Replace any damaged or rotted deck boards. No primer is necessary.

WeatherLock Flex is ideal for use around skylights, valleys and other roof penetrations.

Eave Preparation

2. *WeatherLock Flex* should be applied over the metal drip edge at the eave.
WeatherLock Flex should be applied under the drip edge at the rake.

Installation

3. Unroll *WeatherLock Flex* and cut into two to three equal lengths, depending on length of job. Allow it to relax for 3 to 5 minutes.
4. Reroll each portion. Remove the first 2' of the release backer and press the product into place. Overlap the bottom edge (eave) by ¼".

While supporting the roll with one hand, remove the release backer with the other hand and press or roll into place. *WeatherLock Flex* may be secured with nails (18" on center) on steeper slopes or as needed.

5. Along a valley, *WeatherLock Flex* can be cut lengthwise for easier handling. For maximum protection, the roll width should remain intact and extend 18" on either side of the valley. Peel back the backer sheet and press *WeatherLock Flex* into place working from the center of the valley or ridge outward in each direction. Always apply valleys starting at the low point and work upwards. *WeatherLock Flex* should be applied in valleys before doing eave applications with membrane.
6. *WeatherLock Flex* should extend from eaves to a point 24" inside the exterior wall. This will place the *WeatherLock Flex* well above the maximum ice dam buildup line, in most areas. Consult local building code for specific requirements.
7. If a second course is needed, overlap the second course onto the first course, to a minimum of 3". Continue this same application procedure for additional courses, as needed. Adhesive is not required.
8. Extra courses should be installed using the same application instructions as described in sections 3 and 4. Extra courses may also be installed with nails (18" on center) as needed and depending on the slope of the roof. Use hand pressure or a roller to smooth the lapped area to insure good adhesion.
9. Overlap at least 6" when the ends of two rolls meet.
10. Cover *WeatherLock Flex* with finish roofing material. Do not allow *WeatherLock Flex* to remain uncovered.

Prolonged exposure to sun and weather will adversely affect this product's performance.

Precautions

1. *WeatherLock Flex* should be installed by a professional roofing contractor.
2. *WeatherLock Flex* is designed to be covered by shingles or other roofing material. Protection from sunlight is required to assure its long-term performance.
3. *WeatherLock Flex* is a moisture and vapor barrier. Since ice buildup is partially a function of ventilation, the spaces under the covered deck area and the attic space must be ventilated in accordance with FHA Minimum Property Standards and local building codes.
4. *WeatherLock Flex* is intended for exterior application only.
5. Apply *WeatherLock Flex* directly to the wood deck. Do not apply shingle underlayment beneath *WeatherLock Flex*.
6. Do not remove the cross-laminated polyethylene facer on surface of *WeatherLock Flex* product.
7. Use extreme caution when installing *WeatherLock Flex*. The *WeatherLock* surface is slippery even when dry.

Use of Fall Protection is highly recommended. Consult OSHA for guidelines on Fall Protection (29 CFR 1926.500).

- 8.** For best results, apply *WeatherLock Flex* when the air temperature is over 40°F (5°C) but below 100°F (38°C).
If applied in temperatures below 40°F (5°C), *WeatherLock Flex* is stiffer and will not fully seal until it is warmed. If applied in temperatures above 100°F (38°C), it may become difficult to remove the release paper backing. If this situation should occur, move product into a shaded area until cool. Once cooled, the release paper backing can be easily removed.
- 9.** Store *WeatherLock Flex* in a dry, well-ventilated area. Stand *WeatherLock Flex* upright. Do not store at 90°F (32°C) or warmer for extended periods of time.
- 10.** When applying *WeatherLock Flex*, always follow local building codes and the shingle manufacturer's instructions for installation of its product.

WeatherLock® G Granulated Self-Sealing Ice & Water Barrier

For sloped residential buildings with wood decks

WeatherLock® underlayment installed between the roof deck and asphalt shingles, cedar shakes, concrete tile or slate roofing helps to lock out damage from wind-driven rain and ice damming. This exclusive Owens Corning composition of polyethylene, styrene-butadiene-styrene modified asphalt and a Fiberglas® mat for added reinforcement means *WeatherLock* underlayment can lie flat and remain dimensionally stable. Rain. Shine. Or ice.



WeatherLock underlayment helps to prevent costly damage from ice and water seeping through the roof and roof deck.

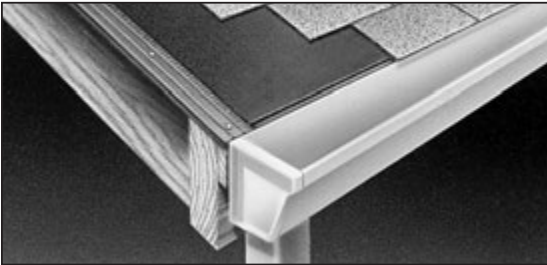

Ice Damming

Continual thawing and refreezing of melting snow or the backup of frozen slush in gutters can cause water leakage.

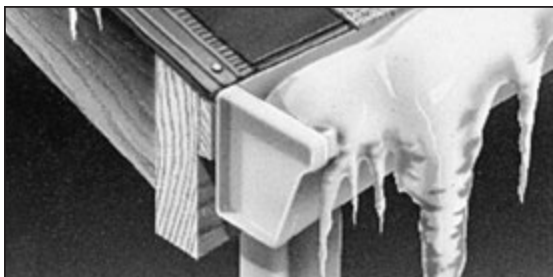

Wind-Driven Rain

Hard, wind-driven rain can cause backup in gutters and drains.

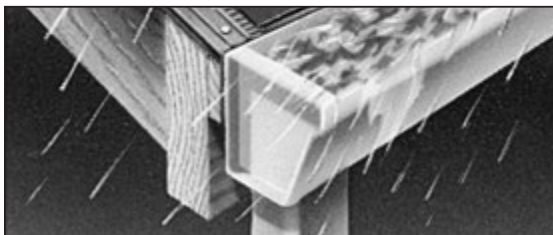

Caution

Read and understand all instructions and precautions before applying *WeatherLock G Granulated Self-Sealing Ice & Water Barrier*.

Deck Preparation

1. Owens Corning® *WeatherLock G* Granulated Self-Sealing Ice & Water Barrier should be applied on roofs having slopes of 1" rise in 12" run or greater.

It can be applied on new construction or when reroofing, provided existing shingles have been removed. Remove all old roofing down to the deck, or, in new construction, apply over the new deck.

Sweep the deck surface to remove dirt and debris. The deck must be clean, smooth and dry before applying *WeatherLock G* Self-Sealing Ice & Water Barrier. Replace any damaged or rotted deck boards. No primer is necessary.

Eave Preparation

2. *WeatherLock G* should be applied over the metal drip edge at the eave; ensure metal drip edge is nailed properly.

WeatherLock G should be applied under the drip edge at the rake.

Installation

3. Unroll *WeatherLock G* and cut into 10' to 20' lengths, depending on length of job. Allow it to relax for 3 to 5 minutes.
4. Reroll each portion. Remove the first 2' of the release backer and press the product into place. Overlap the bottom edge (eave) by 1/4".

While supporting the roll with one hand, remove the release backer with the other hand and press or roll into place. *WeatherLock G* may be secured with nails or staples (18" on center) on steeper slopes or as needed.

5. Along a valley, *WeatherLock G* can be cut lengthwise for easier handling. For maximum protection, the roll width should remain intact and extend 18" on either side of the valley. Peel back the poly backer sheet and press *WeatherLock G* into place working from the center of the valley or ridge outward in each direction. Always apply valleys starting at the low point and work upwards. *WeatherLock G* should be applied in valleys before doing eave applications with membrane.
6. *WeatherLock G* should extend from eaves to a point 24" inside the exterior wall. This will place the *WeatherLock G* well above the maximum ice dam buildup line, in most areas. Consult local building code for specific requirements.
7. If a second course is needed, overlap the second course 3" onto the top of the first course taped selvage edge. The lap area must be firmly hand rolled to insure a watertight bond.
Continue this same application procedure for additional courses, as needed. Adhesive is not required.
8. Extra courses should be installed using the same application instructions as described in sections 3 and 4. Extra courses may also be installed with nails or staples (18" on center) as needed and depending on the slope of the roof. Use hand pressure or a roller to smooth the lapped area to insure good adhesion.
9. Overlap at least 6" when the ends of two rolls meet.
10. Cover *WeatherLock G* with finish roofing material. Do not allow *WeatherLock G* to remain uncovered. Prolonged exposure to sun and weather will adversely affect this product's performance.

Precautions

1. *WeatherLock G* should be installed by a professional roofing contractor.
2. *WeatherLock G* is designed to be covered by shingles or other roofing material. Protection from sunlight is required to assure its long-term performance.
3. *WeatherLock G* is a moisture and vapor barrier. Since ice buildup is partially a function of ventilation, the spaces under the covered deck area and the attic space must be ventilated in accordance with FHA Minimum Property Standards and local building codes.
4. *WeatherLock G* is intended for exterior application only.
5. Apply *WeatherLock G* directly to the wood deck. Do not apply shingle underlayment beneath *WeatherLock G*.
6. Use extreme caution when installing *WeatherLock G*. The *WeatherLock* surface is slippery even when dry.
Use of Fall Protection is highly recommended. Consult OSHA for guidelines on Fall Protection (29 CFR 1926.500).
7. For best results, apply *WeatherLock G* when the air temperature is over 40°F (5°C) but below 100°F (38°C). If applied in temperatures below 40°F (5°C),

WeatherLock G is stiffer and will not fully seal until it is warmed. If applied in temperatures above 100°F (38°C), it may become difficult to remove the release poly backing. If this situation should occur, move product into a shaded area until cool. Once cooled, the release poly backing can be easily removed.

8. Store *WeatherLock G* in a dry, well-ventilated area. Stand *WeatherLock G* upright. Do not store at 90°F (32°C) or warmer for extended periods of time.
9. When applying *WeatherLock G*, always follow local building codes and the shingle manufacturer's instructions for installation of its product.

WeatherLock® Specialty Tile & Metal Waterproofing Barrier

For sloped residential buildings with wood decks

WeatherLock® underlayment installed between the roof deck and metal or tile roofing helps to lock out damage from wind-driven rain and ice damming. This exclusive Owens Corning® Roofing composition is engineered for use under metal or tile.



Caution

Read and understand all instructions and precautions before applying *WeatherLock* underlayment.

For tile roof application

The standard maximum pitch for *WeatherLock* underlayment shall be 6:12 when tiles are loaded directly to the *WeatherLock* underlayment; loading boards are required on roof pitches greater than 6:12.

On slopes 2:12 to 6:12, battens are not required, although tiles should not be stacked higher than 10 tiles per stack.

Tiles shall be stored on battens on roof pitches greater than 6:12.

Deck Preparation

1. Owens Corning® *WeatherLock* underlayment should be applied on roofs having slopes of 2" rise minimum in 12" run or greater.

It can be applied on new construction or when re-roofing, provided existing roofing has been removed. Remove all old roofing down to the deck or, in new construction, apply over the new deck.

Sweep the deck surface to remove dirt and debris. The deck must be clean, smooth and dry before applying *WeatherLock* underlayment. Replace any damaged or rotted deck boards.

Eave Preparation

2. Along eaves, install metal drip edge under the *WeatherLock* underlayment. Along rakes, apply *WeatherLock* underlayment first, and put drip edge on top.

Note: When installing *WeatherLock* product over the entire roof deck, proper ventilation is required. Consult a design professional for proper ventilation requirements.

Installation

3. Unroll *WeatherLock* underlayment and cut into 10' to 20' lengths, depending on size of job. Allow it to relax for 3–5 minutes before installing.

Reroll each portion. Remove the first two feet of the release backer and press the product into place. Overlap the bottom edge (eave) by 1/4". While supporting the roll with one hand, remove the release backer with the other hand and press or roll into place. *WeatherLock* underlayment may be secured with nails (18" on center); back nailing of *WeatherLock* product on slopes 3:12 or greater will be required.

Along a valley, *WeatherLock* underlayment can be cut lengthwise for easier handling. For maximum protection, the roll width should remain intact and extend 18" on either side of the valley. Peel back the poly backer sheet and press *WeatherLock* underlayment into place, working from the center of the valley or ridge outward in each direction. Always apply valleys starting at the low point and work upward. If an overlap is needed, be sure to overlap the previous piece by 4". *WeatherLock* underlayment should be applied in valleys before doing eave applications with membranes.

4. Extra courses should be installed using the same application instructions as described in Section 3. Extra courses may also be installed with nails (18" on center) as needed and depending on the slope of the roof. Use hand pressure or a roller to smooth the lapped area to ensure good adhesion.
5. Overlap at least 6" when the ends of two rolls meet. To ensure good adhesion at the end lap, apply 3"– 4" width of a solvent-based asphaltic primer that complies with ASTM D41 across the width of the composite using a roller, brush, or asphalt roof cement approximately 1/4" thick, 3"– 4" across the width of the composite (excessive roof cement can have an adverse reaction to the product). Good penetration of the primer is essential to the waterproofing integrity of the end lap. Apply heavy hand pressure or use a roller along the seam, overlapping the next roll.
6. Cover *WeatherLock* underlayment with finish roofing material. Do not allow *WeatherLock* underlayment to remain uncovered. Exposure to sun and weather for more than 90 days will adversely affect this product's performance.

Precautions

1. *WeatherLock* underlayment should be installed by a professional roofing contractor.
2. *WeatherLock* underlayment is designed to be covered by roofing material. Protection from sunlight is required to assure its long-term performance.
3. *WeatherLock* underlayment is a moisture and vapor barrier. The spaces under the covered deck area and the attic space must be ventilated in accordance with FHA Minimum Property Standards and local building codes.
4. *WeatherLock* underlayment is intended for exterior application only.
5. Apply *WeatherLock* underlayment directly to the wood deck. Do not apply shingle underlayment beneath *WeatherLock* underlayment.
6. Metal, tiles or shingles should not be installed over wrinkled or buckled *WeatherLock* underlayment.
7. Use extreme caution when installing *WeatherLock* underlayment. The *WeatherLock* underlayment surface is slippery even when dry. Use of fall protection is highly recommended. Consult OSHA for guidelines on fall protection (29 CFR 1926.500).
8. For best results, apply *WeatherLock* underlayment when the air temperature is over 40°F (5°C) but below 100°F (38°C). When temperatures are under 40°F (5°C), *WeatherLock* underlayment will not fully adhere until warmer temperatures. Store at room temperature prior to installing product in cold weather. If applied in temperatures above 100°F (38°C), the release poly backing may become difficult to remove. If this situation should occur, then move product into a shaded area until the *WeatherLock* underlayment is cool. Once cooled, the release poly backing can be easily removed.
9. Store *WeatherLock* underlayment in a dry, well-ventilated area. Stand *WeatherLock* underlayment upright. Do not store at 90°F (32°C) or warmer for extended periods of time.
10. When applying *WeatherLock* underlayment, always follow local building codes and the roofing manufacturer's instructions for installation of its product.

ProArmor®

Synthetic Roof Underlayment

INSTALLATION INSTRUCTIONS

Owens Corning® ProArmor™ Synthetic Roof Underlayment should be applied to a properly prepared dry deck that is smooth, clean and free from any depressions, projections, or protruding nails. Acceptable roof deck materials for application are minimum 3/8" plywood or minimum 7/16" OSB. Roof decks should be structurally sound and meet or exceed minimum requirements of the roof deck manufacturer and local building codes. ProArmor™ underlayment is designed for use under asphalt shingles only and must be covered within 30 days of application.

Always follow safe roofing practices and OSHA safety requirements. Always wear and use fall protection devices when working on roofs. Use caution when walking or standing on ProArmor™ underlayment in wet or dusty conditions that may reduce traction. Failure to use proper safety equipment and footwear can result in serious injury.

Fasteners

If the roof will not be covered with asphalt shingles on the same day, ProArmor™ underlayment must be attached to the roof deck using plastic or steel cap fasteners having a minimum 1" diameter cap. Roofing nails and pneumatic nail guns may be used for same day installations for all slopes. Staples may be used for same day installations on slopes 2:12 to 12:12. All fasteners should be driven straight and flush with the surface. Consult local building codes for fastener type and spacing requirements.

Lap Requirements – All Slopes

If two or more pieces are required to continue a course, lap the ends at least 4" (must be at least 12" for slopes 2:12 to less than 4:12). End laps in a succeeding course should be located at least 6' from laps in the preceding course. Lap ProArmor™ underlayment a minimum of 6" from both sides over all hips, ridges and valleys. Where the roof meets a wall, extend ProArmor™ underlayment a minimum 4" up the wall.

Slopes 4:12 or Greater

Always lay ProArmor™ underlayment parallel to the eaves, lapping each course at least 3" over the underlying course. For same day coverage, minimum fastening locations for roofing nails, pneumatic nail guns or cap nails are shown in Fig. 1 and staples in Fig. 2. If required, additional fasteners can be used for same day coverage. See Fasteners section for additional details.

If ProArmor™ underlayment will not be covered on the same day with asphalt shingles (extended exposure up to 30 days), use only plastic or steel cap fasteners having a minimum 1" diameter cap for all slopes. Fasten in both the overlapping area and the field area of ProArmor™ underlayment. Additional fasteners may be required in high wind regions per local building codes. See Fig. 3 and Fasteners section for details.

Fig 1. Minimum Fastening Locations for Same Day Coverage Using Roofing Nails, Pneumatic Nail Guns or Cap Nails Fig 1.

Fig 1. Ubicaciones mínimas de sujetadores para cobertura el mismo día usando clavos para techos, pistolas neumáticas o clavos con capuchón

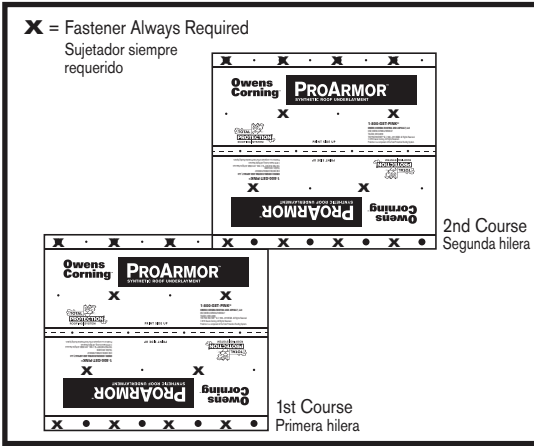
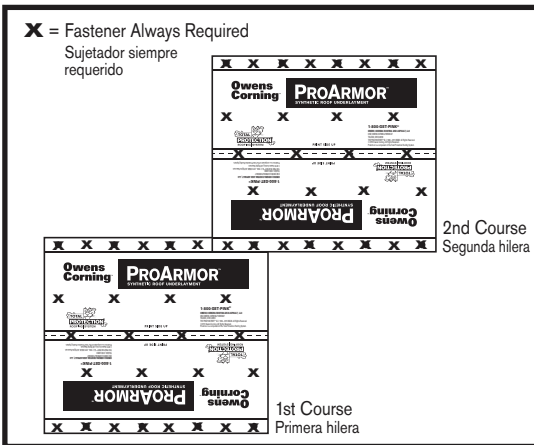

Fig 2. Minimum Fastening Locations for Same Day Coverage Using Staples for Slopes 4:12 to 12:12 Only

Fig 2. Ubicaciones mínimas de sujetadores para cobertura el mismo día usando grapas para pendientes de 4:12 a 12:12 solamente



Slopes 2:12 to less than 4:12

On all lower slope applications, cover the deck with two layers of ProArmor™ underlayment. Roofing nails, pneumatic nail guns and staples may be used for same day installations. If ProArmor™ underlayment will not be covered on the same day with asphalt shingles (extended exposure up to 30 days), use only plastic or steel cap fasteners having a minimum 1" diameter cap. Begin by fastening a 22" wide strip of ProArmor™ underlayment along the eaves with the minimal fasteners needed to hold the course in place. Place a full-width sheet over the 22" course with the long edge placed along the eaves and completely overlapping the initial starter course. All succeeding courses will be a minimum of 42" wide and should be positioned to overlap the preceding course by 22" (to

lowest solid centerline). Additional fasteners may be required in high wind regions per local building codes. See Fig. 4 and Fasteners section for details.

Fig. 3. Minimum Fastening Locations For Extended Exposure on Slopes 4:12 or Greater

Fig. 3. Ubicaciones mínimas de sujeción para exposición extendida en pendientes de 4:12 o superiores

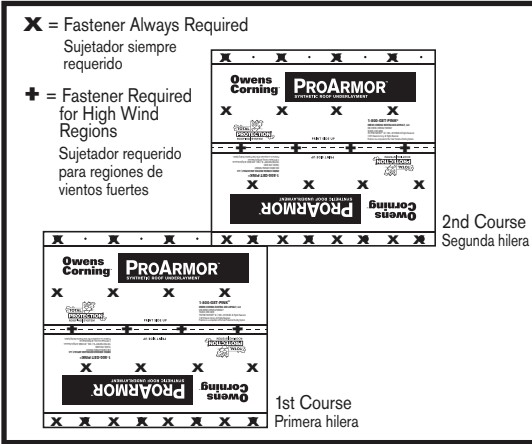
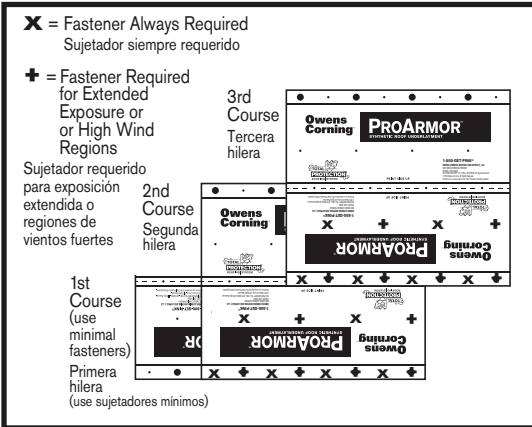

Fig. 4. Fastening Locations for Slopes 2:12 to less than 4:12

Fig. 4. Ubicaciones de sujeción para pendientes de 2:12 a menos de 4:12



⚠ CAUTION

Caution: Roof surface may be slippery, especially when dusty, wet or icy. Use a fall protection system when installing. Wear soft-soled shoes. Walk with care.

Falling Hazard: Secure area below work and materials on roof. Unsecured materials may slide when placed on roof. Place on level plane or secure to prevent sliding. Wear a hard hat.

Caution: Safety glasses should always be worn when using power tools. Wear gloves when installing to avoid cuts and abrasions.

FIBERGLAS™ Reinforced Felt

Owens Corning® Fiberglas™ Reinforced Felt should be applied to a properly prepared dry deck that is smooth, clean and free from any depressions, projections or protruding nails. Roof decks should be structurally sound and meet or exceed minimum requirements of the deck manufacturer and local codes.

Slopes 4" in 12" or more

Always lay the felt underlayment parallel to the eaves, lapping each course at least 2" over the underlying course. Felt underlayment should not run perpendicular to the eaves. Secure the felt underlayment with nails to hold it in place. (See Fig. 1.) Nails should be driven straight and flush with the surface. If two or more pieces are required to continue a course, lap the ends at least 4". End laps in a succeeding course should be located at least 6' from end laps in the preceding course. Lap the felt underlayment a minimum of 6" from both sides over all hips, ridges and valleys. Where the roof meets a vertical surface, carry the felt underlayment at least 4" up the surface.

Fig. 1 Standard Slope

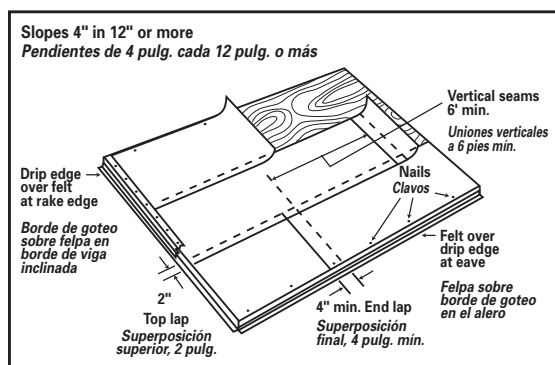

Slopes 2" in 12" to less than 4" in 12"

On low-slope applications, cover the deck with two layers of non-perforated asphalt saturated felt underlayment. (See Fig. 2.) Begin by fastening a 19" wide strip of felt underlayment placed along the eaves. Place a full width sheet over the starter with a long edge placed along the eave and completely overlapping the initial starter course. All succeeding courses will be a minimum of 36" wide and should be positioned to overlap the preceding course by 19". Secure each course by only enough fasteners to hold it in place until the shingles are applied. End laps should be 12" wide and located at least 6' from end laps in the preceding course.

Fig. 2 Low Slope

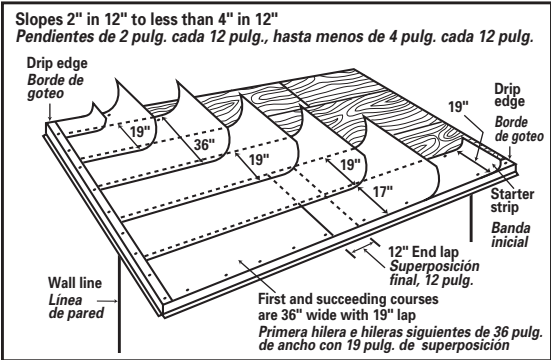

Deck Defense®

High Performance Roof Underlayment

INSTALLATION INSTRUCTIONS

Owens Corning® Deck Defense® High Performance Roof Underlayment should be applied to a properly prepared dry deck that is smooth, clean and free from any depressions, projections, or protruding nails. Roof decks should be structurally sound and meet or exceed minimum requirements of the deck manufacturer and local codes.

Always follow safe roofing practices and OSHA safety requirements. Always use and wear fall protection devices when working on roofs. Some examples are toe boards, rope and harness, and soft-sole footwear. Use caution when walking or standing on Owens Corning™ Deck Defense High Performance Roof Underlayment when wet or dusty conditions exist that may reduce traction. Failure to use proper safety gear and footwear can result in serious injury.

NOTE: Owens Corning® Deck Defense High Performance Roof Underlayment must be attached to the roof deck using plastic or steel cap fasteners having a minimum of 1" diameter cap.

Slopes 4' in 12" or more

Always lay Deck Defense underlayment parallel to the eaves, lapping each course at least 3" over the underlying course. Deck Defense underlayment should not run perpendicular to the eaves. Secure Deck Defense underlayment with cap nails that are 1" in diameter placed in the printed nail areas located on Deck Defense underlayment. See Fig. 1.

Fig. 1 For Standard Application
Fig. 1 Para la instalación estándar

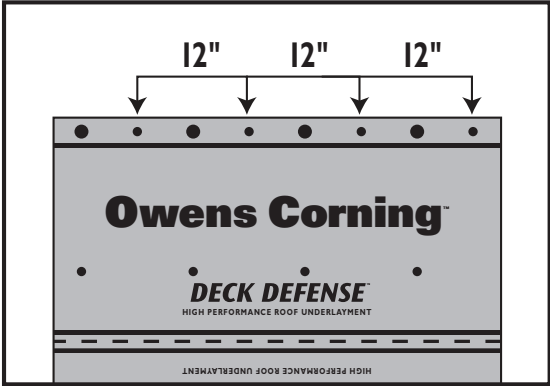

When installing underlayment over an extended period up to 180 days, cap nails should be placed in both the overlapping area and also the center area of the underlayment. See Fig. 2. Nails should be driven straight and flush with the surface. If two or more pieces are required to continue a course, lap the ends at least 4'. End laps in a succeeding course should be located at least 6' from laps in the preceding course. Lap Deck Defense underlayment a minimum of 6" from both sides over all hips, ridges and valleys. Where the roof meets a vertical surface, carry Deck Defense underlayment at least 4" up the surface.

Fig.2 For Application over an Extended Period

Fig.2 Para la instalación durante un tiempo prolongado

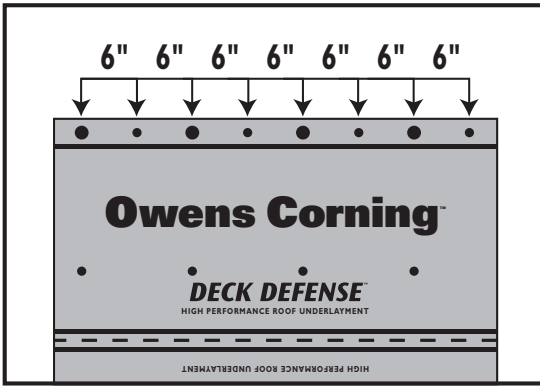

Slopes 2" in 12" to less than 4" in 12"

On low slope applications, cover the deck with two layers of Deck Defense underlayment. See Fig. 3. Begin by fastening a 25"-wide strip of Deck Defense underlayment placed along the eaves. Place a full-width sheet over the starter with a long edge placed along the eave and completely overlapping the initial starter course. All succeeding courses will be a minimum of 48" wide and should be positioned to overlap the preceding course by 25". Secure each course with cap nails 1" in diameter placed in the nailing area every 6" in the overlap area and 12" in the center of Deck Defense underlayment to hold it in place until the shingles are applied. End laps should be 12" wide and nailed every 4" from the edge. Also ensure end laps are located at least 6' from end laps in the preceding course.

Fig.3 Low Slope Application
Fig.3 Instalación en poca pendiente

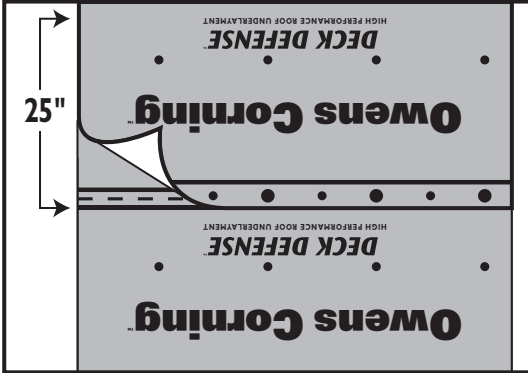

Caution: Roof surface may be slippery, especially when wet or icy. Use a fall protection system when installing. Wear rubber-soled shoes. Walk with care.

Falling Hazard: Secure area below work and materials on roof. Unsecured materials may slide on roof. Place on level plane or secure to prevent sliding. Wear a hard hat.

Caution: Safety glasses should always be worn when cutting the roof with a power tool.

Wear gloves when installing to avoid cuts and abrasions.

Starter Shingle Roll

For use at Eave & Rake



Cut Time—Not Tabs

Starter Shingle Roll from Owens Corning eliminates the need for cutting shingle tabs or inverting them to create a starter row. So you save time.

Easy Application

Application is a snap too. Simply apply a single course of Starter Shingle Roll along a clean, dry and smooth eave line, after removing the release sheet. Apply the Starter Shingle Roll directly onto the WeatherLock® underlayment or a layer of felt. Once it is pressed into place, you're ready to begin shingling.

The Starter Shingle Roll advantages:

- Eliminates time-consuming tab cutting or shingle flopping
- Comes in handy individual rolls, measuring 7.2" wide x 33'4" long (0.183m x 10.18m)
- Easy peel-and-stick application
- Requires no special tools, hardware or training
- Compatible with most Owens Corning® shingles, see back for application instructions
- Meets CCMC 13403-R

Before installing this product, check roofing manufacturer's application instructions and local building codes for their roofing requirements.

Starter Shingle Roll:

1. **Application:** Align Starter Shingle Roll with eave & rake edge granular side up with the seal strip closest to the outer edge of the roof. Remove release backer and press to assure full adhesion to the underlayment. For rake application, install drip edge first before applying. See Fig. 1

NOTE: When rolling out the starter roll ensure the product is laying flat with no humps before pressing into place. For best results, keep the starter roll at room temperature prior to application. When the starter is used with 3 tab shingles, the installer must ensure that nails in the starter are not exposed between the cut outs of the overlaying shingle.

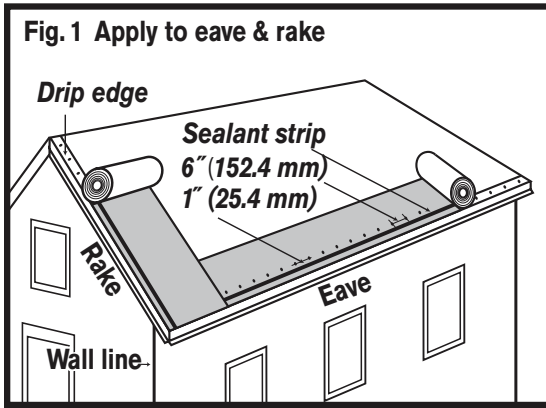

2. Nail placement, when required to obtain max wind warranty for roofing shingles, are installed 1" (25.4 mm) above the sealant strip and spaced every 6" (152.4 mm) along the eave.
3. Apply shingles once Starter Shingle Roll is installed. Apply shingles according to the shingle manufacturer's instructions.

Precautionary Notes:

The manufacturer will not be responsible for problems resulting from any deviation from the recommended application instructions and the following precautions:

Storage: Store this product in a dry, well-ventilated area and stand upright. Do not store for extended periods over 90°F (32°C).

Nails must be corrosion-resistant, 11- or 12-gauge, with heads at least $\frac{3}{8}$ " (9.5 mm) in diameter.

All Fasteners must penetrate at least $\frac{3}{4}$ " (19.0 mm) into the wood deck or completely through plywood sheathing.

Starter Strip Shingle

Goes on right—right away

Starter Strip shingle from Owens Corning Roofing – eliminates the need for cutting shingle tabs to create a starter row, helping to save installation time and money! It's a component of the Owens Corning® Total Protection Roofing System®.



1. Starter Strip is packaged two pieces per shingle, 16 shingles per bundle, 105 lineal feet.
2. Perforation down the center allows for easy separation.
3. Once apart, the Starter Strip shingles should be aligned next to one another with the sealant toward the eave.

Starter Strip shingle advantages:

Speeds installation and helps improve safety. Starter Strip shingle eliminates the need to cut off tabs or headlap.

Saves labor. It's easy for a single person to position Starter Strip shingle on the roof.

Maximum compatibility. Use with any shingle that has an exposure of up to 6"

Improves job quality. Puts the sealant appropriately at the eaves.

Cost savings. There's no need to cut down 3-tab shingles to use as a starter strip.

Clean look. Starter Strip shingle provides a straight edge at the eave and along the rake.

Exceptional bonding strength. Continuous sealant ensures an effective seal between the starter and the first course of shingles.

Convenient. One (1) bundle provides 1 square of material (105 lineal feet of actual coverage).

Application Instructions

Owens Corning® Starter Strip can be used with any shingle that has an exposure of up to 6". Starter Strip shingles cannot be used with Owens Corning®

Berkshire,[®] Woodmoor,[®] Woodcrest,[®] or Devonshire[™] shingles.

Installation of Starter Strip shingle

Starter Strip shingle is designed to be broken into two pieces, and each piece has its own sealant strip. When separated, each starter shingle is 6⁵/₈" x 39³/₈", and each bundle will cover approximately 105 lineal feet. See Fig. 1.

This starter can be used with shingles that have an exposure of no more than 6"; if the exposure is greater than 6", a full starter (13¹/₄" x 39³/₈") would be required. See Fig. 1.

Fig. 1 Starter Strip Shingle

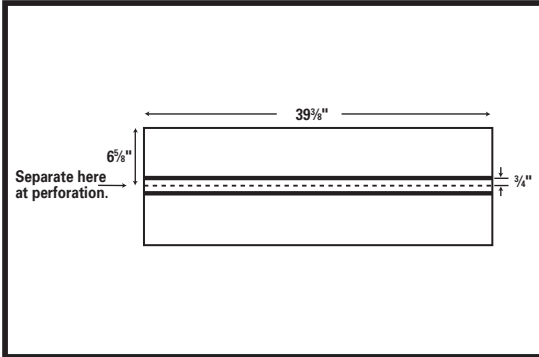

1. Start first Starter Strip shingle with 6" removed from the rake edge and flush with the drip edge. Starter shingle can extend no greater than 3/4" beyond the edge of the eave. Use 5 fasteners placed 2" to 3" from the edge of the eave. See Fig. 2.

Fig. 2 Starter Strip Shingle Application

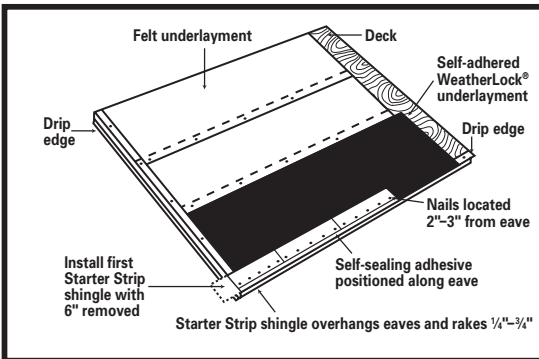

2. During application, the installer must ensure that when the starter is applied, the overlaying shingles' end joints do not line up with the starter end joints. End joints must be a minimum of 4" from the overlaying shingle.

3. When the starter is used with 3-tab shingles, the installer must ensure that nails in the starter are not exposed between the cutouts of the overlaying shingle.
4. When installing Owens Corning® Oakridge® shingles for maximum wind warranty, Starter Strip shingles are required along both the eave and rake edge.

Caution

Roof surface may be slippery: Especially when wet or icy. Use a fall protection system when installing. Wear rubber-soled shoes. Walk with care.

Falling hazard: Secure area below work and materials on roof. Wear a hard hat.

Notice

It is important that attic space be properly ventilated to maintain product performance and to prevent damage from moisture condensation and excessively high attic temperatures. In this regard, FHA and National Building Code Minimum Property Standards must be met.

Product Specifications

Size	13 ¹ / ₄ " x 39 ³ / ₈ " (337 mm x 1000 mm)
Piece Size	6 ⁵ / ₈ " x 39 ³ / ₈ " (168 mm x 1000 mm)
Shingles per Bundle	16
Pieces per Bundle	32 (6 ⁵ / ₈ " x 39 ³ / ₈ " [168 mm x 1000 mm])
Lineal Feet per Bundle	Approximately 105 (32.0 m)

Applicable Standards and Codes

ASTM D3462

ASTM D3161 (Class F Wind Resistance)

ASTM E108/UL 790 (Class A Fire Resistance)*

Florida Product Approval (FL10674)

UL ER2453-01

Starter Strip Plus Shingle

Goes on right—right away

Owens Corning® Starter Strip Plus shingle helps save time by eliminating the need for cutting shingle tabs to create a starter row. It's a component of the Owens Corning® Total Protection Roofing System® ^.



1. Starter Strip Plus is packaged two pieces per shingle, 16 shingles per bundle, 105 lineal feet.

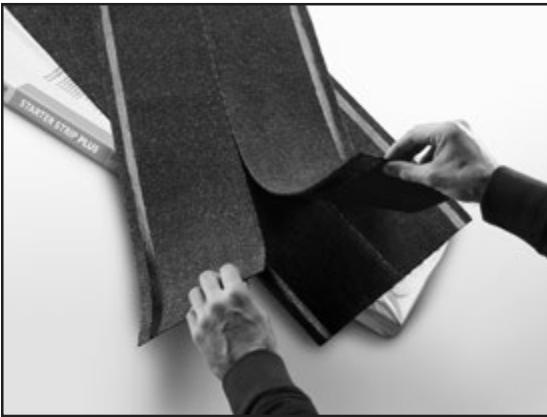

2. Perforation down the center allows for easy separation.



3. Once apart, the Starter Strip Plus shingles should be aligned next to one another with the sealant toward the eave.

Starter Strip Plus shingle advantages:

Speeds installation and helps improve safety. Starter Strip Plus shingle eliminates the need to cut off tabs or headlap.

Clean look. Starter Strip Plus shingle provides a machine-cut straight edge at the eave and along the rake.

Saves labor. It's easy for a single person to position Starter Strip shingle on the roof.

Compatibility. Extra-wide starter can be used with most shingles that have an exposure of up to 6" (per Application Instructions on the reverse side).

Improves job quality. Puts the sealant appropriately at the eaves.

Cost savings. There's no need to cut down field shingles to use as a starter strip.

Exceptional bonding strength. Continuous sealant ensures an effective seal between the starter and the first course of shingles.

Convenient. One (1) bundle provides 1 square of material (105 lineal feet of actual coverage).

Application Instructions

Owens Corning® Starter Strip Plus can be used with any shingle that has an exposure of up to 6". Starter Strip shingles cannot be used with Owens Corning® Berkshire®, Woodmoor®, Woodcrest® or Devonshire® shingles.

Installation of Starter Strip Plus shingle

Starter Strip Plus shingle is designed to be broken into two pieces, and each piece has its own sealant strip. When separated, each starter shingle is 7¾" x 39⅜", and each bundle will cover approximately 105 lineal feet. See Fig. 1.

This starter can be used with shingles that have an exposure of no more than 6"; if the exposure is greater than 6", a full starter (15½" x 39⅜") would be required. See Fig. 1.

1. Start first Starter Strip Plus shingle with 6" removed from the rake edge and flush with the drip edge. Starter Strip Plus shingle can extend no greater than ¾" beyond the edge of the eave. Use 5 fasteners placed 2" to 3" from the edge of the eave. See Fig. 2.
2. During application, the installer must ensure that when the starter is applied, the overlaying shingles' end joints do not line up with the starter end joints. End joints must be a minimum of 4" from the overlaying shingle.
3. When the starter is used with 3-tab shingles, the installer must ensure that nails in the starter are not exposed between the cutouts of the overlaying shingle.
4. When installing Owens Corning® Oakridge® shingles for maximum wind warranty, Starter Strip Plus shingles are required along both the eave and rake edge.

Fig. 1 Starter Strip Plus Shingle

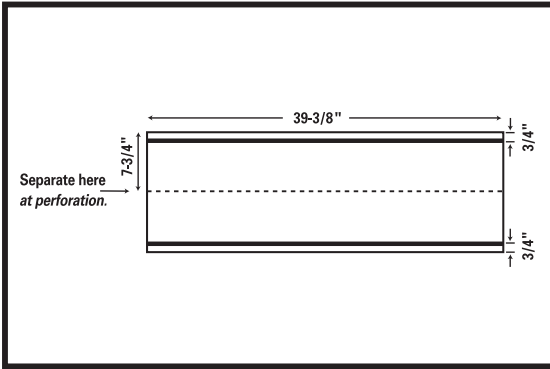
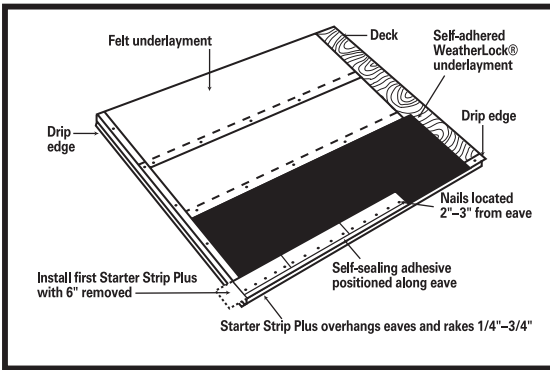

Fig. 2 Starter Strip Plus Shingle Application



Caution

Roof surface may be slippery: Especially when wet or icy. Use a fall protection system when installing. Wear rubber-soled shoes. Walk with care.

Falling hazard: Secure area below work and materials on roof. Wear a hard hat.

Notice

It is important that attic space be properly ventilated to maintain product performance and to prevent damage from moisture condensation and excessively high attic temperatures. In this regard, FHA and National Building Code Minimum Property Standards must be met.

Product Specifications

Size	15½" x 39⅜" (394 mm x 1000 mm)
Piece Size	7¾" x 39⅜" (197 mm x 1000 mm)
Shingles per Bundle	16
Pieces per Bundle	32 (7¾" x 39⅜" [197 mm x 1000 mm])
Lineal Feet per Bundle	Approximately 105 (32.0 m)

Applicable Standards and Codes

- ASTM D3462
- ASTM D3161 (Class F Wind Resistance)
- ASTM E108/UL 790 (Class A Fire Resistance)*
- CSA A123.5**
- Florida Product Approval (FL10674)
- Miami-Dade County Product Approval (09-0915.12)†
- UL ER2453-01

Woodstart® Starter Shingle

Precautionary Note:

The manufacturer will not be responsible for problems resulting from any deviation from the recommended application instructions and the following precautions:

CAUTION: Due to the aggressive nature of our shingle sealant strip, please note the following: To avoid shingles sticking in hot sun, do not have the sealant strip make contact with various objects on the roof, until you are ready to nail the shingle in place.

Roof Top Loading: Lay shingle bundles flat. Do not bend over the ridge.

Roof Deck: ▪ 6" Minimum roof deck boards ▪ Minimum $\frac{3}{8}$ " plywood ▪ Minimum $\frac{7}{16}$ " OSB

Regardless of deck type used, the roofing installer must:

1. Install the deck material in strict compliance with the deck manufacturer's instructions.
2. Prevent the deck from getting wet before, during and after installation.

Ventilation: Must meet or exceed FHA Minimum Property Standards.

Handling: Use extra care in handling shingles when the temperature is below 40°F.

Storage: Store in a covered ventilated area at a maximum temperature of 110° F. Protect shingles from weather when stored at the job site. Do not store near steam pipes, radiators, etc.

Nails must be corrosion-resistant, 11- or 12-gauge, with heads at least $\frac{3}{8}$ " in diameter.

Staples must be 16-gauge minimum, $\frac{15}{16}$ " minimum crown width and sufficient length to penetrate $\frac{3}{4}$ " into wood decking or through APA-rated roof sheathing. Staples are to be corrosion protected.

All Fasteners must penetrate at least $\frac{3}{4}$ " into the wood deck or completely through plywood sheathing.

Notice: Owens Corning recommends the use of nails as the preferred method of attaching shingles to wood decking or other nailable surface.

Specialty Eave Flashing: WeatherLock® underlayment or equivalent eave and flashing membrane applied to a point at least 24" beyond interior wall line. See Fig. 1.

Figure 1

Specialty Eave Flashing

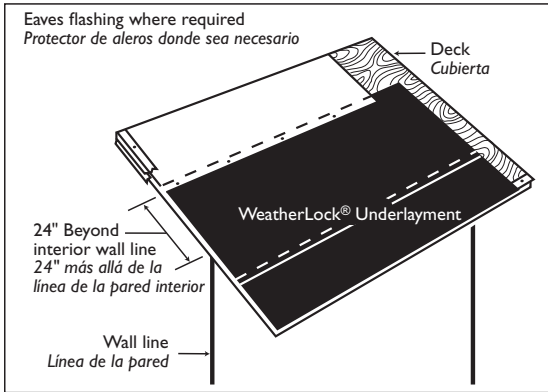

Underlayment:

Standard slope (4" in 12" or more) Application of underlayment, metal drip edges, and eaves flashing. See Fig. 2.

Figure 2

Underlayment Standard Slope

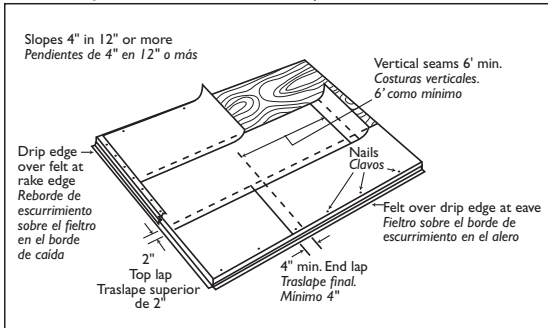

Low slope (2" in 12" to less than 4" in 12") Application of underlayment and metal drip edges. See Fig 2A.

Figure 2A

Underlayment Low Slope

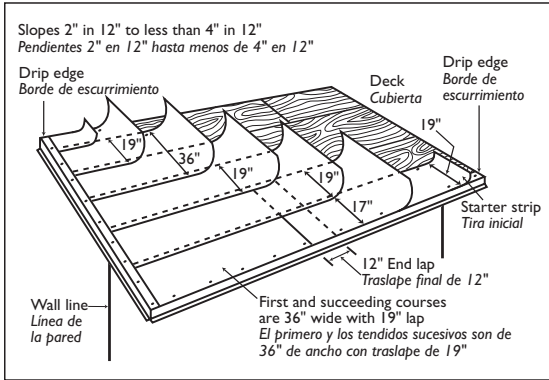

Fastener Placement: See Fig. 3.

Figure 3

Nail Pattern

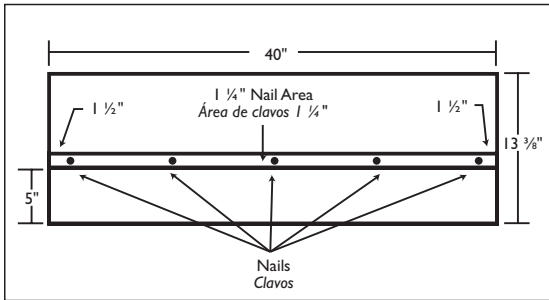

Starter Course:

Left Rake Application: Cut 35" off from the first bottom starter piece. Fasten the remaining 5" x 13³/₈" to the deck as shown in Fig. 4, followed by a full 13³/₈" x 40" starter piece to the deck with 5 fasteners as shown.

Figure 4

Left Rake Application

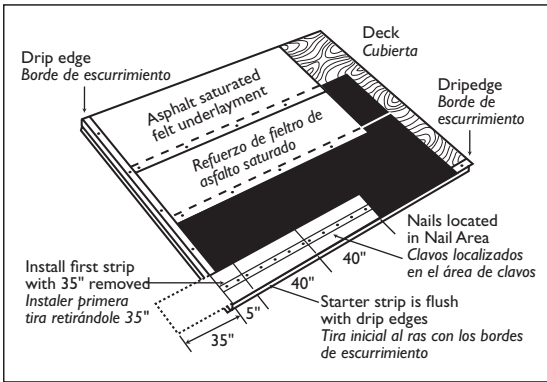

Right Rake Application: Cut 5" off from the first bottom starter piece. Fasten the remaining 35" x 13³/₈" to the deck as shown in Fig. 4A, followed by a full 13³/₈" x 40" starter piece to the deck with 5 fasteners as shown.

Figure 4A

Right Rake Application

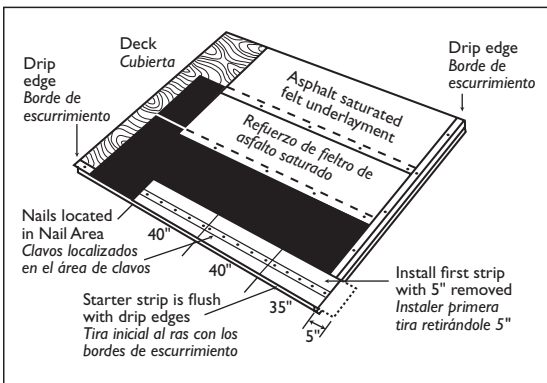

Note: Apply Woodcrest®/Woodmoor® shingles after WoodStart® Starter Shingles are installed. Apply Woodcrest®/Woodmoor® shingles per the application instructions printed on the shingle wrapper.

Made in U.S.A.

LongRidge™ Hip & Ridge

Application Instructions

Complete shingle application on roof deck before applying hip and ridge shingles. *Hip shingles must be applied before ridge shingles.* **Note:** If a new roof is being applied over an existing roof, remove the old hip and ridge shingles to obtain a level application. Each shingle is perforated for separation into three Hip & Ridge shingles.

Precautionary Note: The manufacturer will not be responsible for problems resulting from any deviation from the recommended application instructions and the following precautions:

(A) Handling: Use extra care in handling shingles when the temperature is below 40°F (5°C). DO NOT drop bundles. Shingles can be broken easily in cold weather or their edges damaged in hot weather. DO NOT attempt to separate shingles by “breaking” them over another object such as a ridge.

(B) Fastener requirement: Use galvanized steel, stainless steel, or aluminum nails minimum 12 gauge shank with $\frac{3}{8}$ inch diameter head. Owens Corning Roofing recommends that fasteners comply with ASTM F1667. Check local building codes. All fasteners must penetrate at least $\frac{3}{4}$ inch into the wood deck or completely through plywood or OSB sheathing.

(C) Fastening: Drive all fasteners until they are flush with the surface of the shingle. Special care must be taken when using pneumatic nail guns. Nails are to be driven straight so the entire head is flush against the shingle but does not cut the shingle surface. An improperly adjusted pneumatic gun can result in raised fasteners causing sealing failure, raised tabs, leaks, or blow-off. Place fasteners 10 $\frac{3}{8}$ inch from the butt edge of the shingle. Do not apply fasteners in the sealant strip.

(D) Storage: Store in a covered ventilated area at a maximum temperature of 110°F (43°C). Stack in a flat fashion (maximum of 16 bundles high). Protect shingles from weather when stored at the job site. Do not store near steam pipes, radiators, etc.

(E) All exposed material must be rated Class A by Underwriters Laboratories, to maintain a Class A system.

Hip & Ridge Application

1. Apply Hip & Ridge as shown, bending them over the hip or ridge lengthwise.
2. Apply ridge after hips have been applied, beginning on end of ridge opposite prevailing wind direction. See Fig. 1

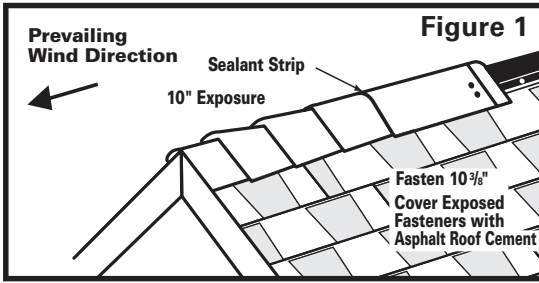

3. Apply shingles with 10 inch exposure.

4. Fasten each shingle with 2 fasteners on each side, 1 inch and 2 inches from the edge and 10³/₈ inch from the exposed end. See Fig. 2

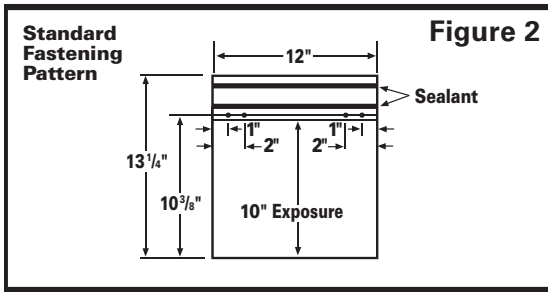

5. Apply remaining hip and ridge shingles in the same manner with a 10 inch exposure.

6. When finishing the ridge, leave no headlap portion of the last hip and ridge shingle exposed. One option is to use the 10 inch exposed portion of a hip and ridge shingle, cutting a piece the appropriate length to extend over the headlap portion of the shingle to the end of the ridge.

7. Fasten final piece with four nails, each 1 inch and 2 inches in from each side edge and 1 inch in from the end of the ridge. Cover exposed fasteners with asphalt roof cement. Asphalt roof cement must meet ASTM D4586 Type I or Type II.

For 130 MPH Wind Warranty

Apply a 1/4 inch wide bead of Elastomeric Sealant that meets ASTM C920 approximately 3 inches long to each side of the hip and ridge shingle. See Fig. 3

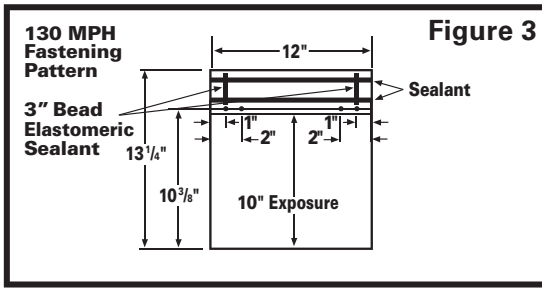

Figure 3

Apply remaining hip and ridge shingles in the same manner with a 10 inch exposure.

When finishing the ridge, leave no headlap portion of the last hip and ridge shingle exposed. One option is to use the 10 inch exposed portion of a hip and ridge shingle, cutting a piece the appropriate length to extend over the headlap portion of the shingle to the end of the ridge.

Fasten final piece with four nails, each 1 inch and 2 inches in from each side edge and 1 inch in from the end of the ridge. Cover exposed fasteners with asphalt roof cement. Asphalt roof cement must meet ASTM D4586 Type I or Type II.

Installing Double Hip & Ridge

Applying a double layer of shingles to hips or ridges is easy to do and creates a more aesthetically pleasing appearance. Simply install the shingles using the method described above, but fasten two shingles simultaneously — one on top of the other. Make sure fasteners are long enough to penetrate through both layers of shingle and completely through the roof deck. See Fig. 4

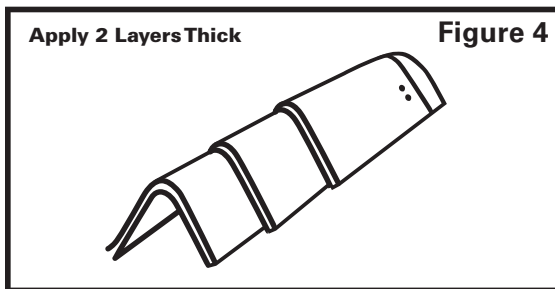

Figure 4

DuraRidge®

Hip & Ridge Shingles

Before You Begin

Complete shingle application on roof deck before applying hip and ridge shingles. Hip shingles must be applied before applying ridge shingles. All hip and ridge shingles are applied with an 8 inch exposure. Note: If a new roof is being applied over an existing roof, remove the old hip and ridge shingles to obtain a level application.

Handling

Use extra care in handling shingles when the temperature is below 40°F. In cold weather, it is recommended to warm DURARIDGE™ shingles before installing.

Fastener Requirement

Use galvanized steel, stainless steel, or aluminum nails minimum 12 gauge shank with $\frac{3}{8}$ " diameter head. Owens Corning Roofing recommends that fasteners comply with ASTM F 1667. Check local building codes. **All Fasteners** must penetrate at least $\frac{3}{4}$ " into the wood deck or completely through sheathing.

Note: Owens Corning Roofing recommends the use of nails as the preferred method of attaching shingles to wood decking or other nailable surface.

Installing

Begin hip application at the eave working toward the ridge.

1. Begin ridge application opposite the prevailing wind direction. (Fig. A)

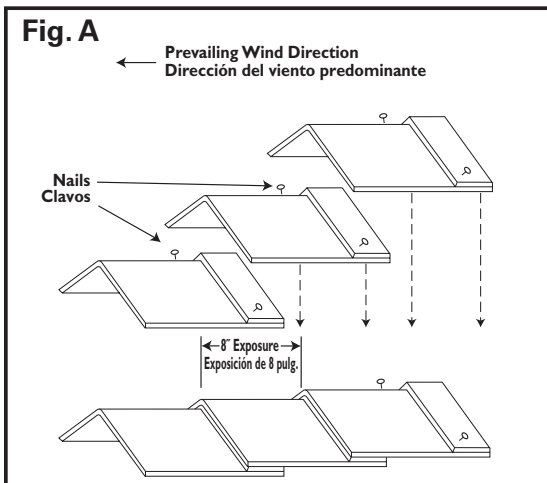

2. Arrange DURARIDGE™ Hip & Ridge shingles along the center line so that both halves of the laminated piece fall on opposite sides of the hip or ridge. (Fig. B)

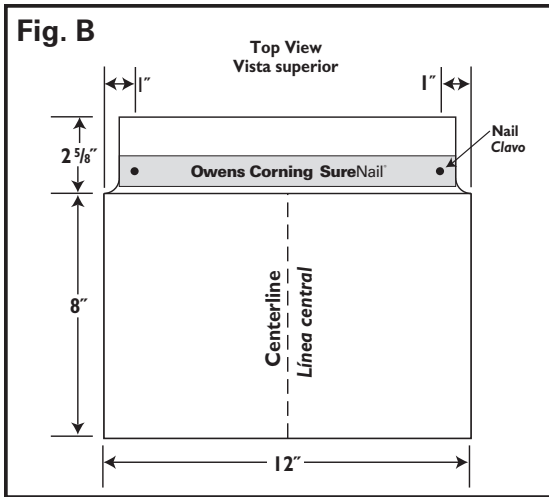

3. Begin application by creating a starting piece using the laminated piece with the 8 inch exposed portion of the shingle removed. Fasten starter piece with one nail on each side 1 inch in from the side edge starting from the fixed side edge placed into the SureNail® Technology fastening area.
4. Continue to fasten each full shingle through the top laminated piece with one nail on each side placed 9 inches back from the exposed end and 1 inch in from the side edge starting from the fixed edge of each shingle. Note: Fasteners must be placed into the SureNail® Technology fastening area. (Fig. B)
5. Apply remaining hip and ridge shingles in the same manner with 8 inch exposure.
6. When finishing the ridge, leave no laminated portion of the last hip and ridge shingle exposed. One option is to use the 8 inch exposure portion of a hip and ridge shingle, cutting a piece the appropriate length to extend over the laminated portion of the shingle to the end of the ridge.
7. Fasten final piece with two nails, each 1 inch in from each side edge and 1 inch in from the end of the ridge. Cover exposed fasteners with asphalt roof cement. Asphalt roof cement must meet ASTM D4586 Type I or Type II (Asbestos Free). Note: Please be aware that excessive amounts of asphalt roof cement could blister the shingle.

Product Specifications

Size	12 inches x 10 3/4" (305 mm x 273 mm)
Pieces per Box	30
Application Exposure	8 inches (203 mm)
Lineal Coverage per Box	20 feet (6.49 m)

- STORE IN COVERED, VENTILATED AREA (UNDER 110°F/43°C)
- DO NOT STACK OVER EIGHT BUNDLES HIGH PER PALLET
- AVOID OUTSIDE STORAGE WHEN TEMPERATURES EXCEED 90°F/32°C
- DO NOT STORE IN DIRECT SUNLIGHT

FAILURE TO FOLLOW THESE STORAGE INSTRUCTIONS COULD CAUSE SHINGLES TO STICK TOGETHER.

Prepared roofing is exempt from OSHA Right-To-Know standard under its provision for articles (29 CFR 1910.1200-b-6-IV) as defined in 29 CFR 1910.1200c

***Limited Lifetime Warranty**

This product carries a limited lifetime warranty (for as long as you own your home). You may obtain a copy of this roofing warranty by visiting our website at www.owenscorning.com or call 1-800-GET-PINK® (1-800-438-7465)

Owens Corning Roofing and Asphalt, LLC shall not be responsible for any damage, loss, cost, expense or liability relating to failure to follow these instructions. Failure to follow these installation instructions may affect Owens Corning Roofing and Asphalt, LLC's obligations under this product's limited warranty.

10-YEAR ALGAE-RESISTANCE LIMITED WARRANTY**

**Tropic zones outside of the USA and Canada have a reduced algae resistance limited warranty. See international warranty for more details.

RIZERidge®

Hip & Ridge Shingles

Precautionary Notes

Owens Corning® RIZERidge® Hip and Ridge Shingles are packaged 22 shingles per bundle with 3 perforated hip and ridge pieces per shingle.

Fastener requirements. Use galvanized steel, stainless steel, or aluminum nails minimum 12 gauge shank with $\frac{3}{8}$ " diameter head with a length long enough to penetrate through the roofing material a minimum of $\frac{3}{4}$ " into roofing sheathing. Where the roof sheathing is less than $\frac{3}{4}$ " thick, the fasteners shall penetrate through the sheathing. Fasteners shall comply with ASTM F1667.

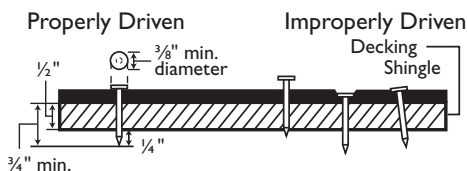

Preparation of Hip and Ridge

Separate hip and ridge at the perforation, each piece should measure 12" x 12", there are 3 pieces per shingle (See Fig. 1)

1. Starter course for a ridge

Fold the upper portion of the individual hip and ridge shingle. (See Fig. 2) Once folded cut the 6" exposed region off from the folded stack. Use this folded stack section as the starter for the first hip and ridge shingle (See Fig. 3)

2. Starter should be installed opposite the prevailing wind for gable end homes. For hip roofs start at the eaves edge.
3. Place the shingle edge of the hip and ridge on top of the starter and nail in place into the double folded area of the shingle.

4. 2 Nail Standard Application

The nails should be placed 7" from the bottom edge and 1" from each side edge (See Fig. 4)

5. 4 Nail 130-MPH Application for Duration® Series Shingles with SureNail® Technology

Four nails and hand sealing must be used to maintain the 130-MPH wind warranty.* The nails should be placed 7" from the bottom edge and 1 and 2" in from each side edge. (See Fig. 4A) Apply a $\frac{1}{4}$ " wide by 2" long bead of elastomeric sealant that meets ASTM C-920 approximately $1\frac{1}{2}$ " in from side edge. (See Fig. 4A)

6. Place and align another folded shingle onto the secured shingle and repeat across the ridge. (See Fig. 5)

*See actual warranty for complete details, limitations and requirements.

Figure 1 Hip & Ridge Shingle

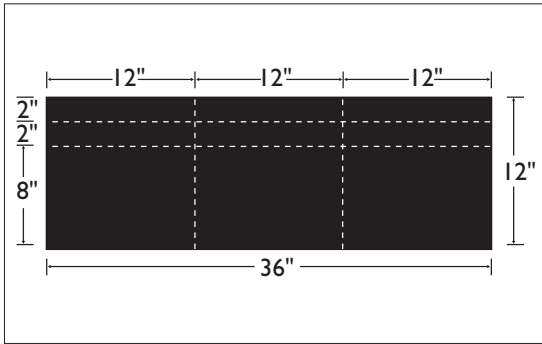

Figure 2 Folded Hip & Ridge Shingle

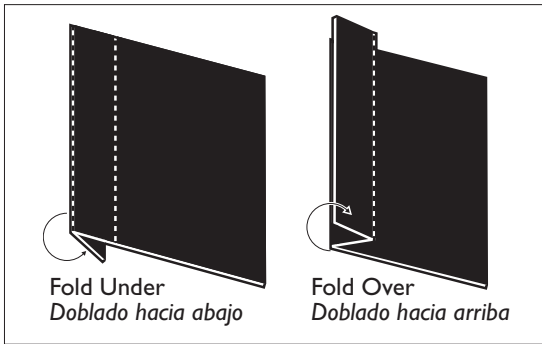

Figure 3 Folded Ridge Starter Shingle

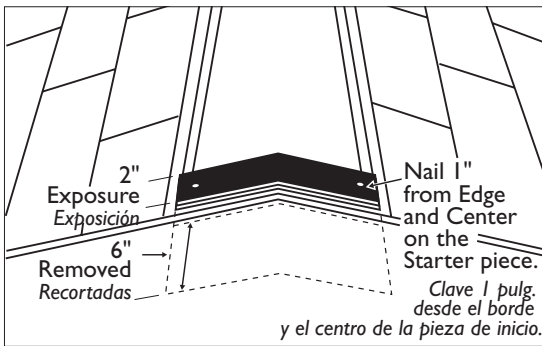

Figure 4 Two Nail Standard Application

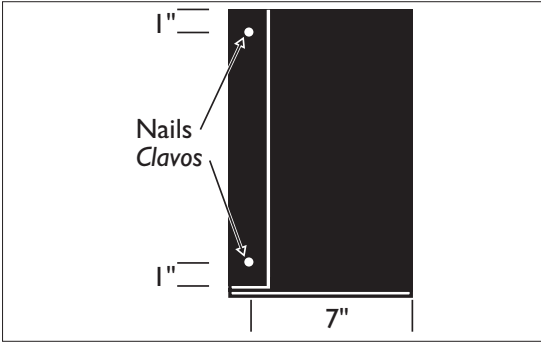

Figure 4A Four Nail 130-mph Application

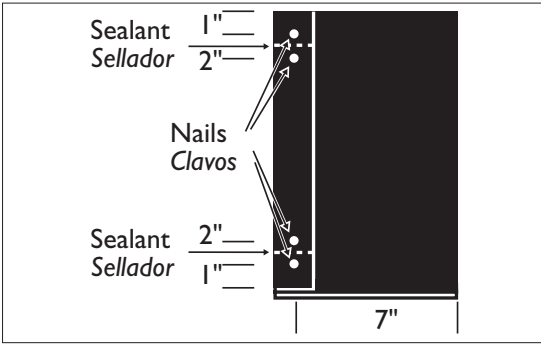
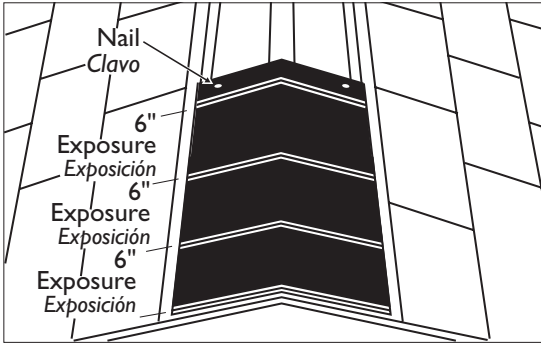

Figure 5 Succeeding Courses



DecoRidge®

Hip & Ridge Shingles

Complete shingle application on roof deck before applying hip and ridge shingles. Hip shingles must be applied before applying ridge shingles. All hip and ridge shingles are applied with an 8" exposure.

Note: If a new roof is being applied over an existing roof, remove the old hip and ridge shingles to obtain a level application.

Use nails only when installing this product. Nails must be corrosion resistant, 11 or 12 gauge, with heads at least $\frac{3}{8}$ " in diameter.

Standard Fastening Pattern: One nail should be placed 8½" back from the exposed end and ½" in for each side edge. (Fig. 1)

Figure 1
8" or 10" width

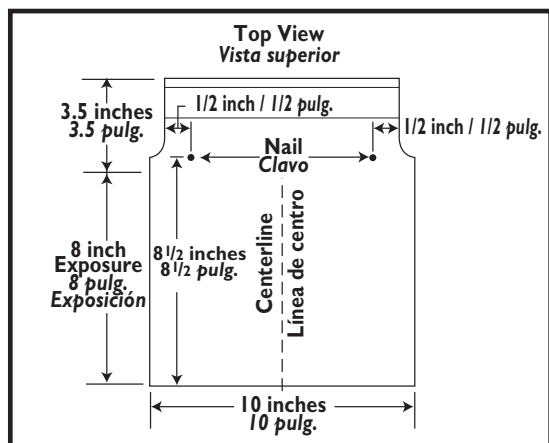

Application

1. Begin hip application at the eave working toward the ridge.
 - 1a. Begin ridge application opposite the prevailing wind direction. (Fig. 2)
2. Cut first hip and ridge 8" back from the exposed end. Use the top portion of the shingle with sealant as the "starter" hip or ridge shingle. (Fig. 2)

Figure 2

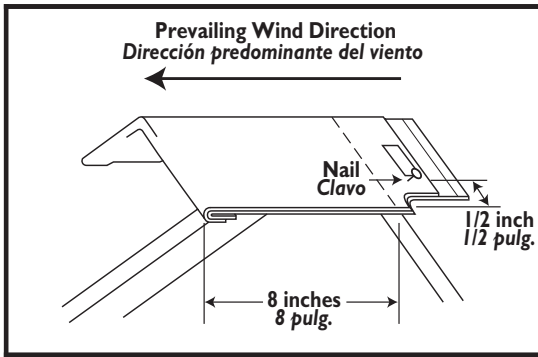

3. Install this "starter" shingle positioned at the leading edge of the hip or ridge. Follow Standard Fastening Pattern in Fig. 1.
4. Completely cover "starter" shingle with the 8" exposed portion of the next hip and ridge shingle. (Fig. 3)

Figure 3

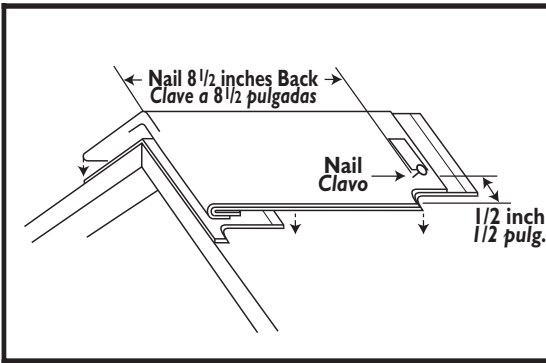

5. Fasten each shingle through the dimensional fold, following the Standard Fastening Pattern in Fig. 1. All nails must be covered by succeeding shingles. Apply remaining hip and ridge shingles in the same manner.
6. Cut final ridge shingle from the 8" exposed portion of a hip and ridge shingle. Cut piece appropriate length to the end of the ridge. (Fig. 4)

Figure 4

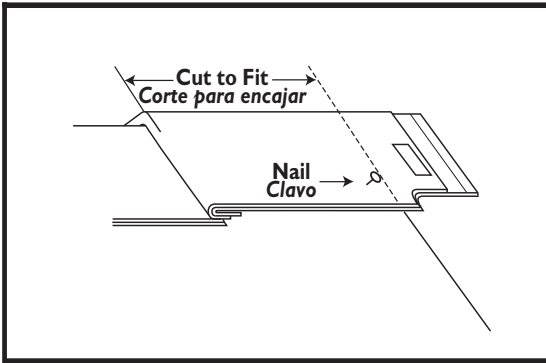

7. Standard fastening pattern: Fasten final piece with two nails, $\frac{1}{2}$ " in from each side edge and 1" in from the end of the ridge. Cover nail with roof cement. (Fig. 4)

ProEdge®

Hip & Ridge Shingles

Complete shingle application on roof deck before applying hip and ridge shingles. *Hip shingles must be applied before ridge shingles.* **Note:** If a new roof is being applied over an existing roof, remove the old hip and ridge shingles to obtain a level application. Each shingle is perforated for separation into three Hip & Ridge shingles.

Precautionary Notes: The manufacturer will not be responsible for problems resulting from any deviation from the recommended application instructions and the following precautions.

- (A) Handling:** Use extra care in handling shingles when the temperature is below 40°F (5°C). DO NOT drop bundles. Shingles can be broken easily in cold weather or their edges damaged in hot weather. DO NOT attempt to separate shingles by "breaking" them over another object such as a ridge.
- (B) Fastener requirement:** Use galvanized steel, stainless steel, or aluminum nails minimum 12 gauge shank with 3/8" diameter head. Owens Corning recommends that fasteners comply with ASTM F 1667. Check local building codes. All fasteners must penetrate at least 3/4" into the wood deck or completely through plywood or OSB sheathing.
- (C) Fastening:** Drive all fasteners until they are flush with the surface of the shingle. Special care must be taken when using pneumatic nail guns. Nails are to be driven straight so the entire head is flush against the shingle but does not cut the shingle surface. An improperly adjusted pneumatic gun can result in raised fasteners causing sealing failure, raised tabs, leaks, or blow-off. Place fasteners 7 1/2" from the butt edge of the shingle. Do not apply fasteners in the sealant strip.
- (D) Storage:** Store in a covered, ventilated area at a maximum temperature of 110°F (43°C). Stack in a flat fashion (maximum of 24 bundles high). Protect shingles from weather when stored at the job site. Do not store near steam pipes, radiators, etc.
- (E) All exposed material must be rated Class A by Underwriters Laboratories, to maintain a Class A system.**

Hip & Ridge Application

1. Apply Hip & Ridge as shown, bending them over the hip or ridge lengthwise.
2. Apply ridge after hips have been applied, beginning on end of ridge opposite prevailing wind direction. See Fig. 1

Figure 1

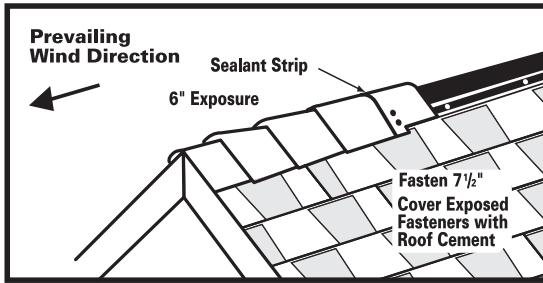

3. Apply shingles with 6" exposure.
4. Fasten each shingle with 2 fasteners on each side, 1 inch and 2 inches from the edge and 7 1/2 inch from the exposed end. See Fig. 2

Figure 2

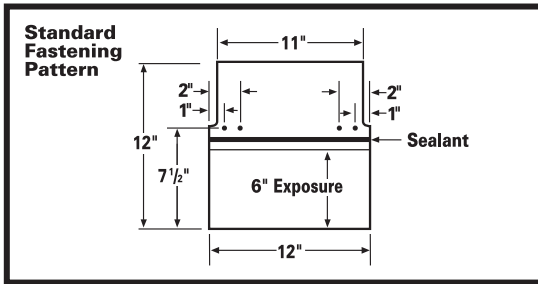

5. Apply remaining hip and ridge shingles in the same manner with a 6 inch exposure.
6. When finishing the ridge, leave no headlap portion of the last hip and ridge shingle exposed. One option is to use the 6 inch exposed portion of a hip and ridge shingle, cutting a piece the appropriate length to extend over the headlap portion of the shingle to the end of the ridge.
7. Fasten final piece with four nails, each 1 inch and 2 inches in from each side edge and 1 inch in from the end of the ridge. Cover exposed fasteners with asphalt roof cement. Asphalt roof cement must meet ASTM D-4586 Type I or Type II (Asbestos Free).

Installing Double Hip & Ridge

Applying a double layer of shingles to hips or ridges is easy to do and creates a more aesthetically pleasing appearance. Simply install the shingles using the method described above, but fasten two shingles simultaneously — one on top of the other. Make sure fasteners are long enough to penetrate through both layers of shingle and completely through the roof deck. See Fig. 3

Figure 3

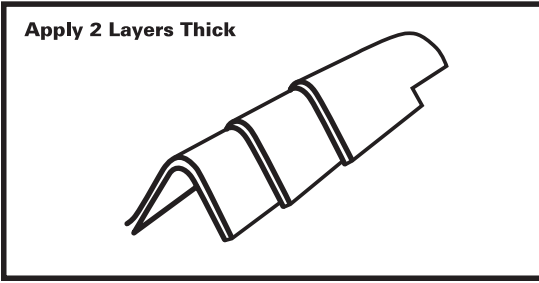

CAUTION: DO NOT MIX MATERIAL BEARING DIFFERENT LOT NUMBERS, REFER TO THE LOT NUMBERS LOCATED ON THE SIDE OF THE BUNDLE

ProEdge STORM® AR

Hip & Ridge Shingles with WeatherGuard® Technology

Owens Corning® ProEdge STORM™ Hip & Ridge Shingles are designed to complement TruDefinition® Duration STORM® Impact Resistant Shingles.

Note: Off ridge vents should be used. Use of shingle-over ridge vent will affect the impact resistance classification.

Complete shingle application on roof deck before applying hip and ridge shingles. *Hip shingles must be applied before ridge shingles.* If a new roof is being applied over an existing roof, remove the old hip and ridge shingles to obtain a level application. Each shingle is perforated for separation into three Hip & Ridge shingles.

High Wind: To maintain the 130-MPH wind warranty you must nail each hip and ridge shingle with 4 nails and hand seal each shingle using the High Wind Zone application. See Fig. 3

Precautionary Notes

The manufacturer will not be responsible for problems resulting from any deviation from the recommended application instructions and the following precautions.

- (A) Handling:** Use extra care in handling shingles when the temperature is below 40°F (5°C). DO NOT drop bundles. Shingles can be broken easily in cold weather or their edges damaged in hot weather. DO NOT attempt to separate shingles by “breaking” them over another object such as a ridge.
- (B) Fastener requirement:** Use galvanized steel, stainless steel, or aluminum nails minimum 12 gauge shank with $\frac{3}{8}$ inch diameter head. Owens Corning recommends that fasteners comply with ASTM F1667. Check local building codes. All fasteners must penetrate at least $\frac{3}{4}$ inch into the wood deck or completely through sheathing.
- (C) Fastening:** Drive all fasteners until they are flush with the surface of the shingle. Special care must be taken when using pneumatic nail guns. Nails are to be driven straight so the entire head is flush against the shingle but does not cut the shingle surface. An improperly adjusted pneumatic gun can result in raised fasteners causing sealing failure, raised tabs, leaks, or blow-off. Place fasteners $6\frac{1}{4}$ inch from the butt edge of the shingle and above the sealant strip (see Fig. 1) Do not apply fasteners in the sealant strip.
- (D) Storage:** Store in a covered, ventilated area at a maximum temperature of 110°F (43°C). Stack in a flat fashion (maximum of 24 bundles high). Protect shingles from weather when stored at the job site. Do not store near steam pipes, radiators, etc.
- (E) All exposed material must be rated Class A by Underwriters Laboratories, to maintain a Class A system.**

Hip & Ridge Application

1. Apply Hip & Ridge as shown, bending them over the hip or ridge lengthwise. See Fig. 1

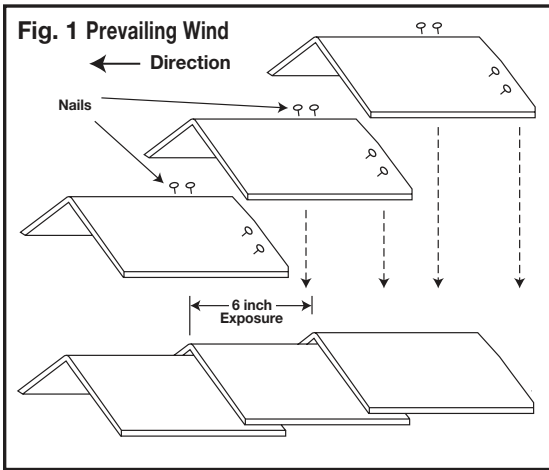

2. Apply ridge after hips have been applied, beginning on end of ridge opposite prevailing wind direction. See Fig. 1
3. Apply shingles with a 6 inch exposure.
4. Fasten each shingle with 2 fasteners on each side, 1 inch and 2 inches from the edge and 6 $\frac{1}{4}$ inch from the exposed end. See Fig. 2

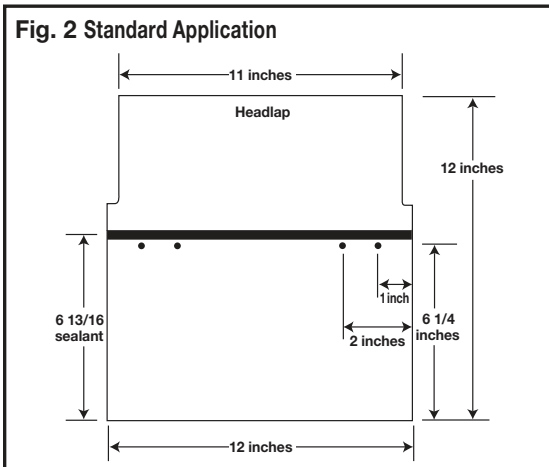

FOR 130-MPH WIND WARRANTY Apply a 1/4 inch wide bead of Elastomeric Sealant that meets ASTM C-920 approximately 1 inch in from edge and approximately 5 inches long to each side of the hip and ridge shingle. See Fig. 2

Fig. 3 High Wind Zones For 130-mph Wind Warranty

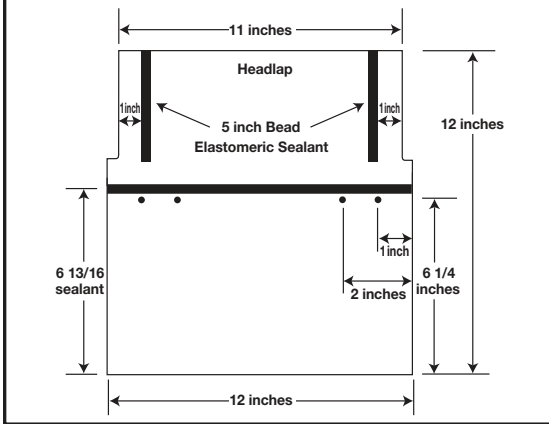

5. Apply remaining hip and ridge shingles in the same manner with a 6 inch exposure.
6. When finishing the ridge, leave no headlap portion of the last hip and ridge shingle exposed. One option is to use the 6 inch exposed portion of a hip and ridge shingle, cutting a piece the appropriate length to extend over the headlap portion of the shingle to the end of the ridge.
7. Fasten final piece with four nails, each 1 inch and 2 inches in from each side edge and 1 inch in from the end of the ridge. Cover exposed fasteners with asphalt roof cement. Asphalt roof cement must meet ASTM D-4586 Type I or Type II (Asbestos Free).

CAUTION: DO NOT MIX MATERIAL BEARING DIFFERENT LOT NUMBERS, REFER TO THE LOT NUMBERS LOCATED ON THE SIDE OF THE BUNDLE

Berkshire[®] Hip & Ridge Shingles

Berkshire[®] AR Hip & Ridge Shingles with Sealant

Application Instructions for Berkshire[®] Hip & Ridge Shingle Cap

For Miami-Dade County approval, the four-nail fastening pattern must be used.

Before You Begin

Complete shingle application on roof deck before applying hip and ridge shingles. Hip shingles must be applied before applying ridge shingles. All hip and ridge shingles are applied with an 8" exposure. Note: If a new roof is being applied over an existing roof, remove the old hip and ridge shingles to obtain a level application.

Handling

Use extra care in handling shingles when the outdoor temperature is below 40°F.

Fastening

Use nails only when installing this product. Nails must be corrosion resistant, 11- or 12 gauge, with heads at least $\frac{3}{8}$ " in diameter. Owens Corning recommends that fasteners comply with ASTM F1667. For the **Standard Fastening Pattern**, nails should be placed 9" back from the exposed end and 1" in from the side edge. (Fig. 2) For the **Four-Nail Fastening Pattern**, apply two nails on each side 9" from the exposed end, and 1" and 2" from the side edge. (Fig. B) All fasteners must penetrate at least $\frac{3}{4}$ " into wood deck or completely through plywood sheathing. Cover exposed fasteners on last hip and ridge shingle with asphalt roof cement. Asphalt roof cement must meet ASTM D 4586 Type I or II (Asbestos Free).

Installing

Begin **hip** application at the eave working toward the ridge.

1. Begin **ridge** application opposite the prevailing wind direction. (Fig. 1/Fig. A)

Standard Nail Fastening Pattern

Figure 1

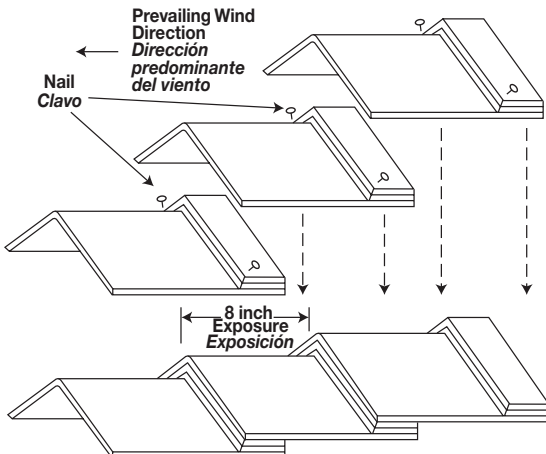

2. Arrange Berkshire® Hip & Ridge shingles along the center line so that both halves of the laminated piece fall on opposite sides of the hip or ridge. (Fig. 2/ Fig. B)

Figure 2

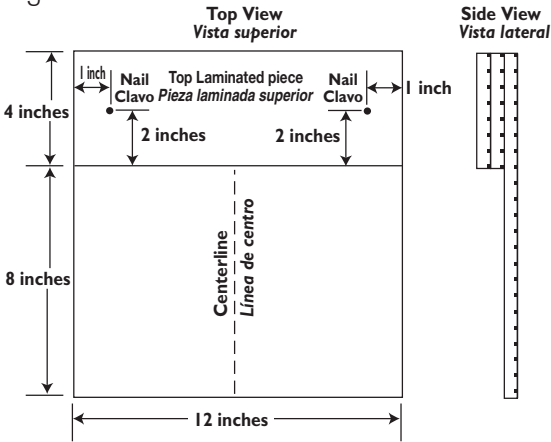

3. For the **Standard Fastening Pattern**, fasten each shingle through the top laminated piece with one nail on each side, placed 10" back from the exposed end and 1" in from the side edge. (Fig. 2) For the **Four-Nail Fastening Pattern**, fasten each shingle through the top laminated piece with two nails on each side, placed 9" back from the exposed end and 1" and 2" in from the side edge. (Fig. B)

Four-Nail Fastening Pattern

Figure A – Berkshire® Hip & Ridge Shingle Application

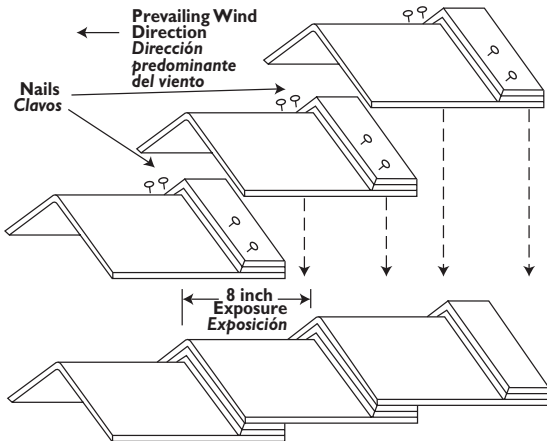

4. Apply remaining hip and ridge shingles in the same manner with 8" exposure.
5. When finishing the ridge, leave no laminated portion of the last hip and ridge shingle exposed. One option is to use the 8" exposed portion of a hip

and ridge shingle, cutting a piece the appropriate length to extend over the laminated portion of the shingle to the end of the ridge.

- For the **Standard Fastening Pattern**, fasten final piece with two nails, each 1" in from the side edge and 1" in from the end of the ridge. For the **Four-Nail Fastening Pattern**, fasten final piece with four nails, each 1" and 2" in from each side edge and 1" in from the end of the ridge. For **both fastening patterns**, cover exposed fasteners with asphalt roof cement.

Figure B – Hip & Ridge Shingle Fastening

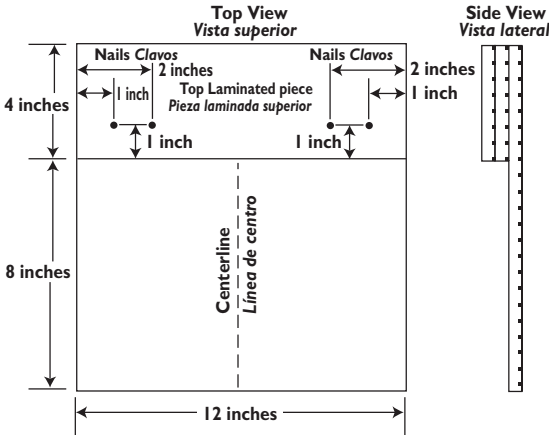

WeatherGuard® HP

Hip & Ridge Shingles

APPLICATION INSTRUCTIONS

CAUTION: DO NOT MIX MATERIAL BEARING DIFFERENT LOT NUMBERS; REFER TO THE LOT NUMBERS LOCATED ON THE SIDE OF THE BUNDLE.

Owens Corning® **WeatherGuard®** HP Hip & Ridge shingles are designed to complement **WeatherGuard®** HP shingles.

NOTE: Use of shingle-over ridge vent will affect the impact resistance classification.

Before You Begin

Complete shingle application on roof deck before applying hip and ridge shingles. Hip shingles must be applied before applying ridge shingles. All hip and ridge shingles are applied with a 5" exposure. **To maintain the 130-MPH wind warranty, you must nail each hip and ridge shingle with 4 nails and hand seal each shingle using the High Wind Zone application. See Fig. B.**

Failure to hand seal will reduce the wind warranty to 110 MPH for the hip and ridge shingle. See Fig. C.

Fastening

Use nails only when installing this product. Nails must be corrosion-resistant, 11- or 12-gauge, with heads at least $\frac{3}{8}$ " in diameter.

1. Separate each piece of **WeatherGuard®** Hip & Ridge shingle into three individual ridge cap shingle pieces at perforations.
2. All fasteners must penetrate at least $\frac{3}{4}$ " into wood deck or completely through plywood sheathing. Cover exposed fasteners on last hip and ridge shingle with asphalt cement. Roof cement must meet ASTM D-4586 Type I or II (Asbestos Free).

For High Wind Zones

Apply a $\frac{1}{4}$ " wide bead of elastomeric sealant that meets ASTM C920 approximately 1" in from edge and approximately 5" long to each side of the hip and ridge shingle. See Fig. B.

Installing

Begin hip application at the eave, working toward the ridge.

1. Begin ridge application opposite the prevailing wind direction. See Fig. A.
2. Arrange **WeatherGuard®** HP Hip & Ridge shingles along the centerline so that both halves fall on opposite sides of the hip or ridge.
3. Fasten each shingle through the top with two nails on each side, placed 6" back from the exposed end and 1" and 2" in from the side edge. See Fig. B.
4. Apply remaining hip and ridge shingles in the same manner with 5" exposure.

5. When finishing the ridge, leave no headlap portion of the last hip and ridge shingle exposed. One option is to use the 5" exposed portion of a hip and ridge shingle, cutting a piece the appropriate length to extend over the headlap portion of the shingle to the end of the ridge.
6. Fasten final piece with four nails, each 1" and 2" in from each side edge and 1" in from the end of the ridge. Cover exposed fasteners with asphalt roof cement.

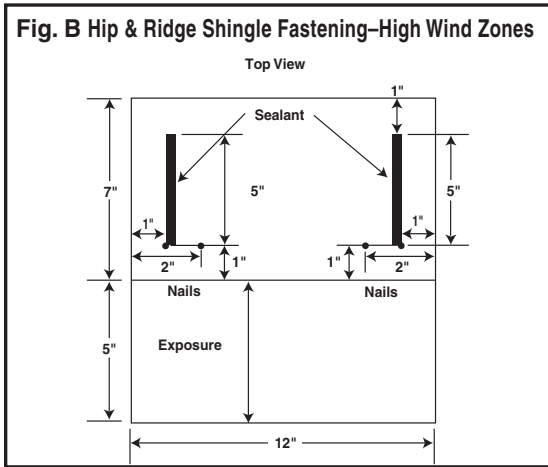
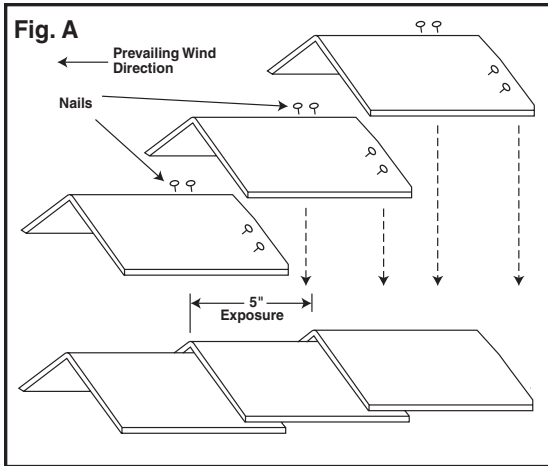
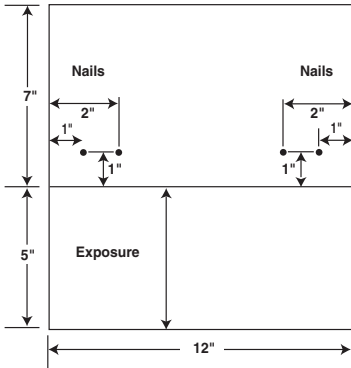

Fig. C Hip & Ridge Shingle Fastening

Top View



Caution: Roof surface may be slippery, especially when wet or icy. Use a fall protection system when installing. Wear rubber-soled shoes. Walk with care.

Falling Hazard: Secure area below work and materials on roof. Unsecured materials may slide on roof. Place on level plane or secure to prevent sliding. Wear a hard hat.

Caution: Safety glasses should always be worn when cutting the roof with a power tool.

Wear gloves when installing to avoid cuts and abrasions.

VentSure® InFlow® Vent

4-Foot Strip Eave Application

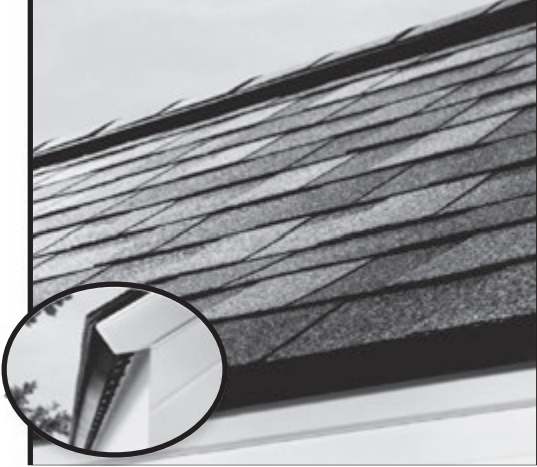

The following instructions are to be used when installing the VentSure® InFlow® Vent at the eave of the roof.

Important Note – Please review the following instructions thoroughly before beginning your installation.

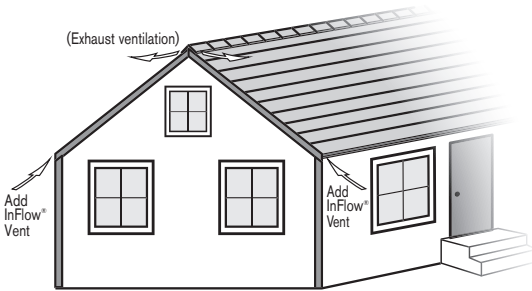

Typical “Eave” InFlow® Vent Application
Primary Intake on “Cape Cod” or
Other “Soffit-less” Homes

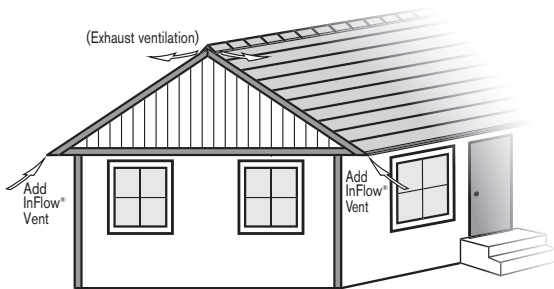

Typical “Eave” InFlow® Vent Application
Supplemental Intake on Soffit Homes which are
Under-ventilated or where Intake is Blocked

Precautionary Notes:

Before installing this product, check local building codes for their roofing and ventilation requirements. This vent is designed for new or re-roofing work over any properly built and supported wood roof deck having adequate nail-holding capacity and a clean, smooth surface.

The InFlow® Vent is designed for roof slopes 4:12 or greater. The manufacturer will not be responsible for issues resulting from any deviation from the recommended application instructions and the following precautions

Roof Deck

- Maximum 6" width and 25/32" minimum thickness wood sheathing
- Minimum 3/8" plywood sheathing or 7/16" OSB
- Sheathing spaced minimum 1/8" and decking spaced maximum 1/4"
- Check local building codes or decking recommended by APA Ventilation
- Must comply with local building code requirements.

Fasteners

- The InFlow® Vent is packaged with 3" ring shank nails to be used when installing the vent and any roofing materials installed directly on the vent.
- Follow roof covering manufacturer's guidelines and local code requirements for all other fasteners.

Tools and materials required to install a VentSure InFlow Vent

- Utility knife
- Tape measure
- Circular saw
- Hammer
- 3" Hand Nails (provided with the vent)
- Chalk line

- Underlayment/self-adhering membrane
- Drip edge (for eave)
- Starter and Roofing Shingles
- Rake edge metal (minimum 1 1/4" vertical leg)

Cutting the 1 1/2" Vent Slot Opening

Step 1: Install drip edge along the eave per local code requirements.

Step 2: Chalk a line from rake edge to rake edge that is 6 1/2" above the lower edge of the drip edge or eave edge.

Step 3: Chalk an additional line, 1 1/2" above this line. These lines will identify the top and bottom edges of the vent slot opening.

Step 4: Make marks on the roof 6" in from the gable end wall at each rake edge. The marks will identify the ends of the vent slot opening. See Figure 1.

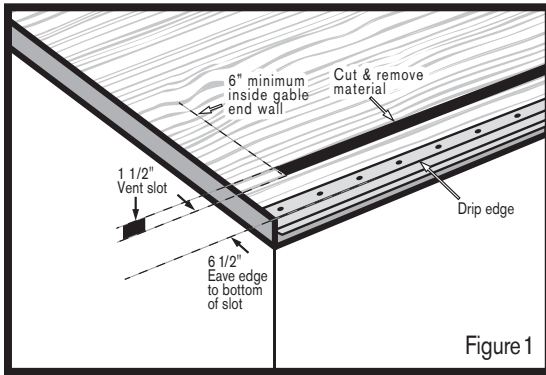

Figure 1

Note: The vent slot opening must stop 6" from chimneys, end walls, vertical walls, or other obstructions, and a minimum of 24" from roof valleys. See Figure 2.

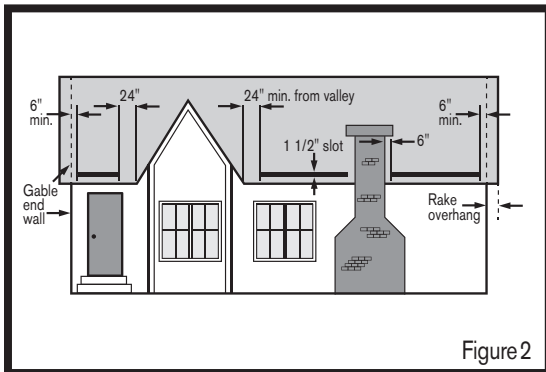

Figure 2

Step 5: Using a circular saw with the depth set to the thickness of the roof deck, cut and remove all materials from the area identified for the vent slot opening.

Note: To provide full ventilation, be sure to maintain at least 1" of clearance between the attic insulation and the bottom of the roof deck.

Installing Underlayment beneath the InFlow® Vent

Step 6: Install a minimum 18" wide piece of underlayment starting at the eave edge. This will cover the slot opening and protect the roof deck below the vent. Identify where the slot opening is underneath the underlayment and cut out the 1 1/2" slot using a sharp utility knife. See Figure 3.

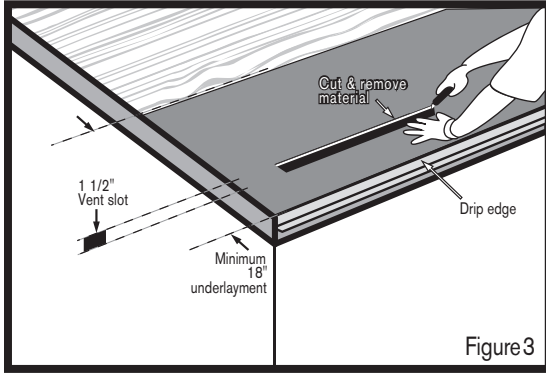

Installing the Vent

Step 7: Position the first InFlow® Vent flush with the rake edge, aligning the vent so the alignment notch is even with the eave edge. This will ensure the vent overhangs the eave edge by 1", allowing air intake through the bottom of the InFlow. See Figure 4.

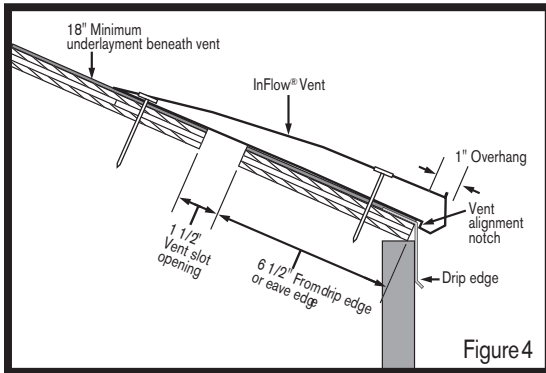

Step 8: Using the nails provided, hand-nail InFlow® Vents in place using the built-in nail holes. Continue installing vents flush with each other from rake edge to rake edge. When installing the final vent, cut the non-rake edge of the vent (if necessary), to ensure a factory-finished edge is flush with the rake edge. See Figure 5.

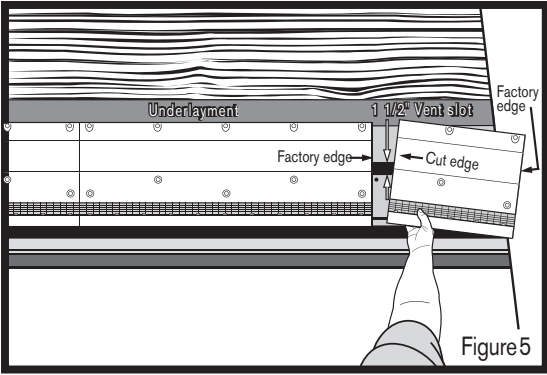

Installing Remaining Shingles & Underlayment

Step 9: Once the InFlow® Vents are installed across the roof, install an underlayment or WeatherLock® Ice & Water Barrier over all vents, at the eave, and at the rake edges per local code requirements. Ensure the bottom edge of the underlayment is flush with the lip at the lower edge of the vent, completely covering the top intake openings.

IMPORTANT: The InFlow® Vent's top intake openings must be completely covered, as air intake occurs through the bottom of the vent with an eave install. See Figure 6 and 7.

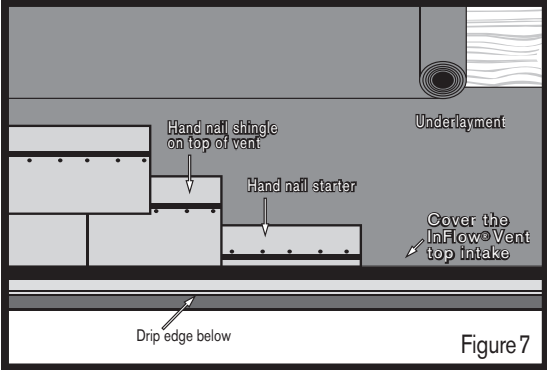
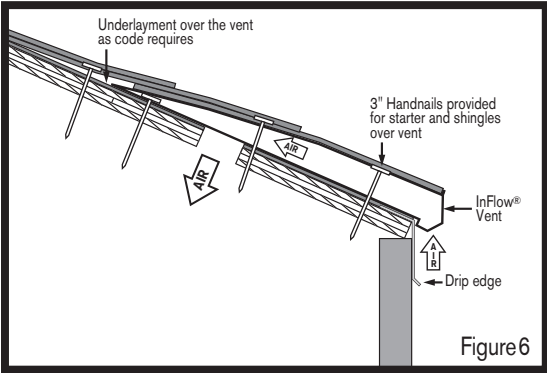

Note: In cold climates where code requires the use of an ice and water barrier, it must extend 24" above the exterior wall. It may be necessary to install a second course of an ice and water barrier to meet this code requirement.

Step 10: Finish installing an approved underlayment over the entire roof, per shingle manufacturer's instructions. Once the underlayment is in place, install rake edge metal over the entire rake, including the InFlow® Vent.

Note: Rake edge metal with a 1¼" minimum vertical leg will completely conceal the factory-finished edge of the InFlow® Vent.

Step 11: Hand nail the starter and roofing shingles on top of the vent using the 3" nails provided. See Figures 6 and 7.

Note: Be sure that all nails fully penetrate the wood deck and do not fall within the vent slot opening. Consult your shingle manufacturer for recommendations as required.

Step 12: Continue shingle system installation per manufacturer's specifications.

Note: A nail gun and standard roofing nails can be used to install shingle courses above the InFlow® Vent, per shingle manufacturer's specification.

VentSure® InFlow® Vent 4-Foot Strip Mid-Roof Application

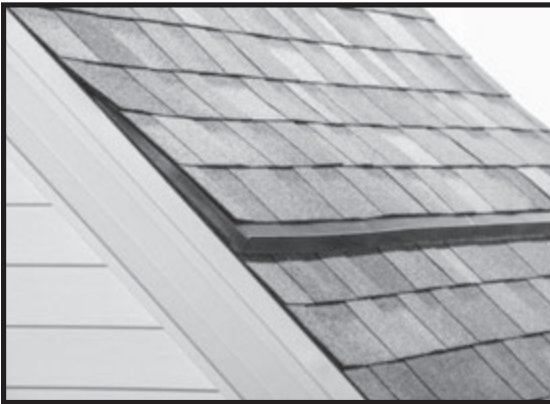

The following instructions are for installing the VentSure® InFlow® Vent up the roof slope beyond the eave, where eave application is not possible or will not allow proper intake ventilation into the attic space.

Important Note – Please review the following instructions thoroughly before beginning your installation.

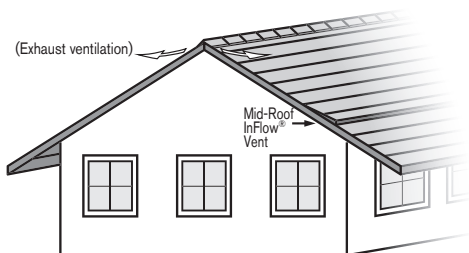

**Typical “Mid-Roof” InFlow® Vent Application
Exposed Rafters or Open Soffits**

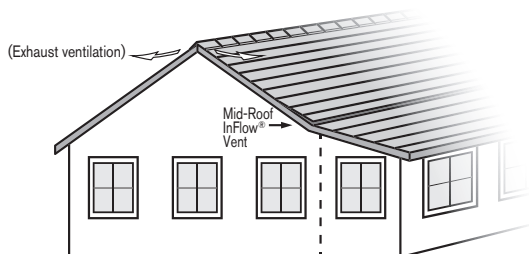

**Typical “Mid-Roof” InFlow® Vent Application
Conditioned Living Area to Unconditioned Porch**

Precautionary Notes:

Before installing this product, check local building codes for their roofing and ventilation requirements. This vent is designed for new or re-roofing work over any properly built and supported wood roof deck having adequate nail-holding capacity and a clean, smooth surface.

The InFlow® Vent is designed for roof slopes 4:12 or greater. The manufacturer will not be responsible for issues resulting from any deviation from the recommended application instructions and the following precautions:

Roof Deck

- Maximum 6" width and 25/32" minimum thickness wood sheathing
- Minimum 3/8" plywood sheathing or 7/16" OSB
- Sheathing spaced minimum 1/8" and decking spaced maximum 1/4"
- Check local building codes or decking recommended by APA

Ventilation

- Must comply with local building code requirements.

Fasteners

- The InFlow® Vent is packaged with 3" ring shank nails to be used when installing the vent and any roofing materials installed directly on the vent.
- Follow roof covering manufacturer's guidelines and local code requirements for all other fasteners.

Tools and materials required to install a VentSure® InFlow® Vent:

- Utility knife
- Tape measure
- Circular saw
- Hammer
- 3" Hand Nails (provided with the vent)
- Chalk line
- Underlayment/self-adhering membrane
- Starter and Roofing Shingles

Installing Initial Courses of Shingles & Underlayment

Step 1: Starting at the eave's edge and continuing up two courses beyond the exterior wall beneath the roof, install shingles and underlayment per manufacturer's instructions. Nail the second course of shingles 4 1/2" above the lower edge of this same shingle course. See Figure 1.

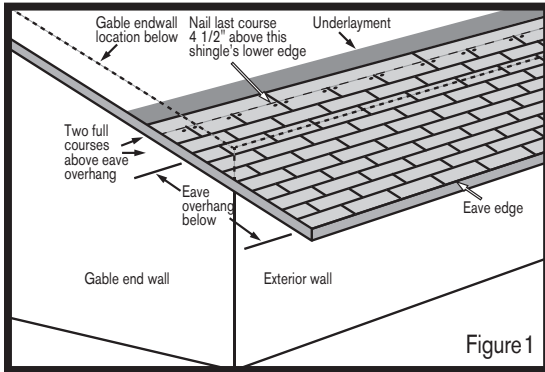

Cutting the 1 1/2" Vent Slot Opening

Step 2: Chalk a line from rake edge to rake edge that is 5" above the lower edge of the last course of shingles installed.

Step 3: Chalk an additional line, 1 1/2" above this line. These lines will identify the top and bottom edges of the vent slot opening.

Step 4: Make marks on the roof 6" in from the gable end wall at each rake edge. The marks will identify the ends of the vent slot opening. See Figure 2.

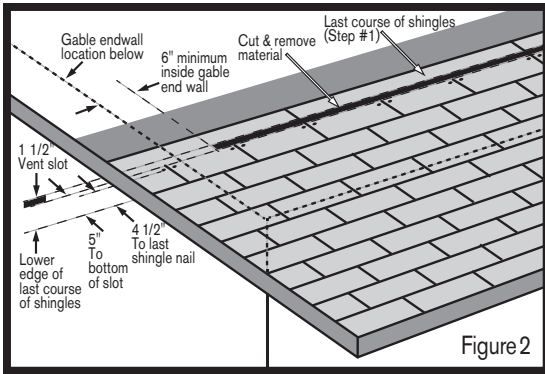

Note: The vent slot opening must stop 6" from chimneys, end walls, vertical walls, or other obstructions, and a minimum of 24" from roof valleys. See Figure 3.

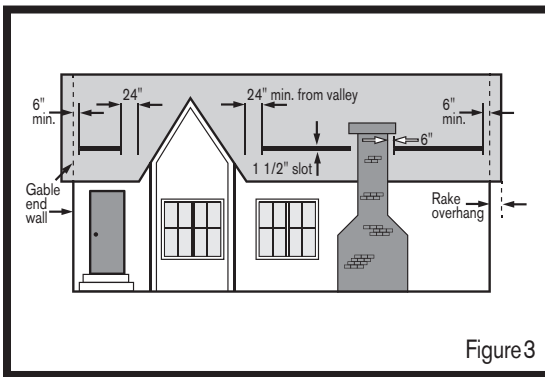

Step 5: Using a circular saw with the depth set to the thickness of the roofing materials plus the roof deck, cut and remove all materials from the area identified for the vent slot opening.

Note: To provide full ventilation, be sure to maintain at least 1" of clearance between the attic insulation and the bottom of the roof deck.

Installing the Vent

Step 6: Position the first InFlow® Vent flush with the rake edge, aligning the vent so the alignment notch is even with the lower edge of the last shingle course installed. See Figure 4.

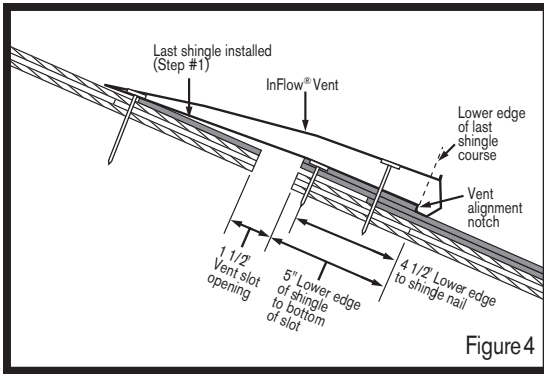

Figure 4

Step 7: Using the nails provided, hand-nail the InFlow® Vent in place using the built-in nail holes. Continue installing vents flush with each other from rake edge to rake edge. When installing the final vent, cut the non-rake edge of the vent (if necessary), to ensure a factory- finished edge is flush with the rake edge. See Figure 5.

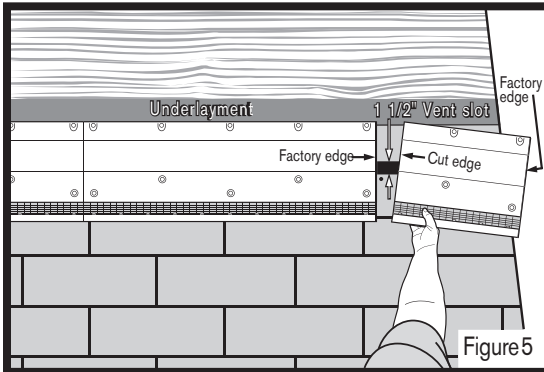
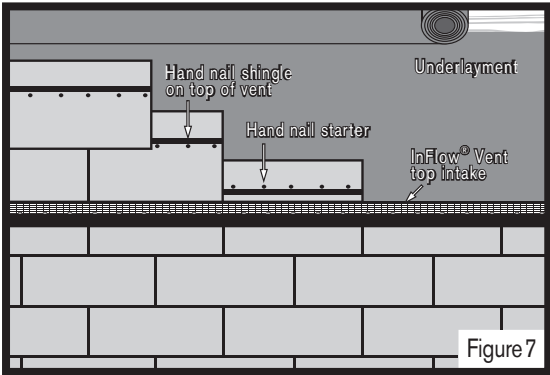
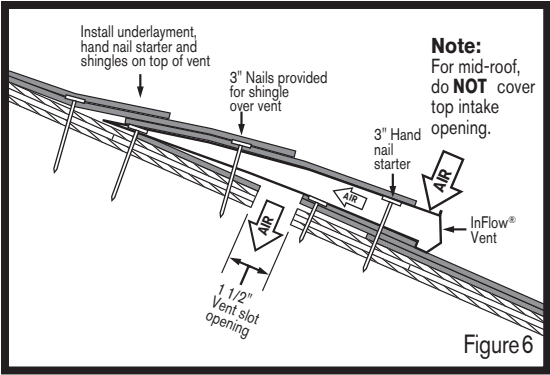

Figure 5

Installing Remaining Shingles & Underlayment

Step 8: Once the InFlow® Vent is installed, install underlayment and hand nail starter shingles and one course of roofing shingles on top of the vent using the 3" nails provided. **IMPORTANT: Do not cover the InFlow® Vent's top intake openings.** This will allow air intake through the top of the vent.

Note: Ensure all nails fully penetrate the wood deck and do not fall within the vent slot opening. Consult your shingle manufacturer for recommendations if needed. See Figures 6 & 7.



Step 9: Continue shingle system installation per manufacturer's specifications.

Note: A nail gun and standard roofing nails can be used to install shingle courses above the InFlow® Vent, per manufacturer's specification.

For installation conditions which are not addressed by these instructions, please contact us at 1-800-GET-PINK (1-800-438-7465) or visit www.owenscorning.com for further instructions.

RidgeCat® Rolled Ridge Vent

Precautionary Notes:

Read all instructions before proceeding.

When using pneumatic roofing coil nailers, ensure the depth gauge is set to the minimum depth to penetrate at least $\frac{3}{4}$ inch into the roof deck or completely through. The pressure should be set between 80 and 95 PSI.

Nails must be corrosion-resistant, 11 or 12 gauge, with heads at least $\frac{3}{8}$ inch in diameter and comply with ASTM F1667. Use of ring shank nails may be required by some local building codes¹. All fasteners must be installed flush with the ridge vent surface and penetrate $\frac{3}{4}$ inch into the wood deck or $\frac{1}{8}$ inch through APA rated roof sheathing.

RidgeCat™ Vent can be installed on roof pitches ranging from 2:12 to 18:12.

Follow the Occupational Safety and Health Admin (OSHA) safety standard for roofing.

¹ *Installation under the HVHZ requirements of the Florida Building Code*

Step 1: Determining Ventilation Requirements

1) Determine the total required length of the ventilation slot according to the 1/150 rule (1 square foot of ventilation area for each 150 square feet of attic floor). For a balanced system, no more than 50% of the required ventilation should be installed at the ridge or hips.

Step 2: Cutting the Vent Slot Opening

1) Determine the type of roof framing that is used under the roof sheathing.

2) For roofs with a ridge board, cut a 1 inch slot in the roof sheathing beyond each side of the ridge board. For an engineered truss roof, cut a 1 inch slot on each side of the ridge (total slot width of 2 inches).

IMPORTANT: Start and end your cut 6 inches in from the rake edges

(snapping chalk lines will aid in keeping a uniform ridge opening). Set your saw depth to cut the decking only. Do not cut into the roof framing. See Figure 1.

Note: The ventilation slot may be cut prior to or after shingle installation. If installing the slot on a roof with shingles installed, use of a circular saw with a carbide tip blade is recommended (Protective eye goggles should be worn during this process).

3) Expose the vent slot opening by removing the decking that was just cut between the rake edges. See Figure 1.

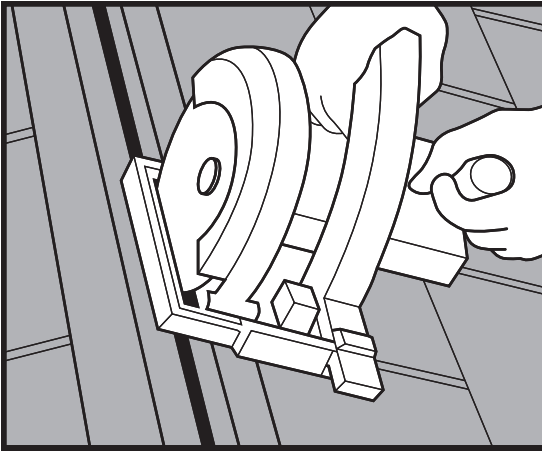

Fig. 1

Step 3: Install shingles up to the ridge slot opening according to shingle manufacturer's instructions.

Step 4: Apply Asphalt Roofing Cement

1) With the shingles installed and the slot opening exposed, install a bead of asphalt roofing cement 3 inches below the vent slot opening on each side of the ridge, and at each end. The sealant should run the entire length of the ridge and should "picture frame" the slot. This will help fill in any gaps between the vent and the shingles, particularly when using laminate shingles. See Figure 2.

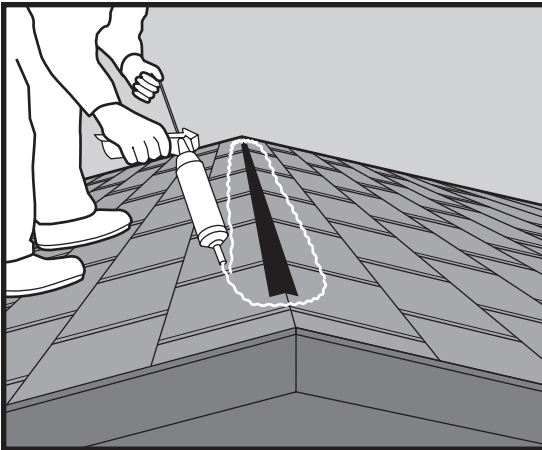

Fig. 2

Note: Use Asphalt Roofing Cement complying with ASTM D4586.

Step 5: Installing the Ridge Vent

1) Prior to installing RidgeCat® Vent, cut a minimum 6-inch wide hip & ridge shingle and nail it over the ridge at each rake edge. See Figure 3.

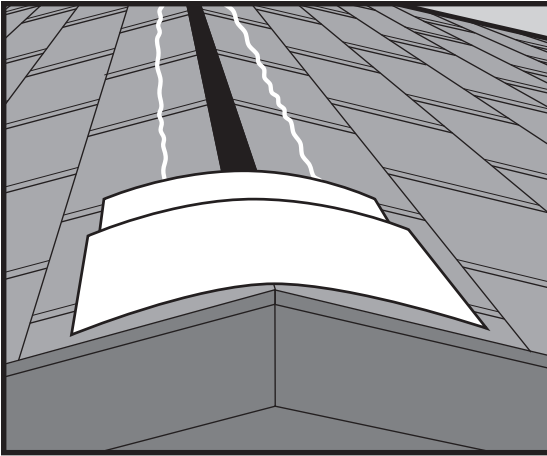

Fig. 3

Note: For the best appearance run the ridge vent from rake edge to the rake edge.

2) Center the RidgeCat® Vent over the slot opening and secure the starting end by applying one nail to the vent on each side of the ridge slot opening, nailing in the printed Tack Line.

Note: The RidgeCat® Vent brand name printed on the center of the vent can be used to help center over the ridge.

3) Roll out the vent along the entire ridge, keeping it centered as you go. Once the vent is rolled out, remove any slack and nail the opposite end as described in the previous step.

4) Secure the vent along the entire ridge by nailing in the printed Tack Lines. One nail should be placed every 3 to 4 feet, on each side of the ridge. See Figure 4.

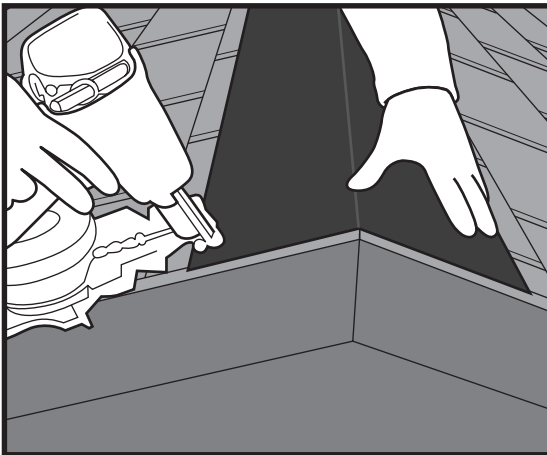

Fig. 4

Note: Nails must penetrate at least $\frac{3}{4}$ inch into the wood deck. If the deck is less than $\frac{3}{4}$ inch thick the nail should be long enough to penetrate fully and extend $\frac{1}{8}$ inch through the roof deck.

Step 6: Connecting Two Pieces of RidgeCat® Vent Together

- 1) When two separate pieces of RidgeCat® Vent need to be joined together along the ridge, center a cap shingle directly under the location where the vent pieces will be joined together, and secure with 1 nail on each side of ridge.
- 2) Align the two vent pieces together without overlapping and then fasten by nailing each vent piece on both sides of the ridge to hold the vents in place. See Figure 5.

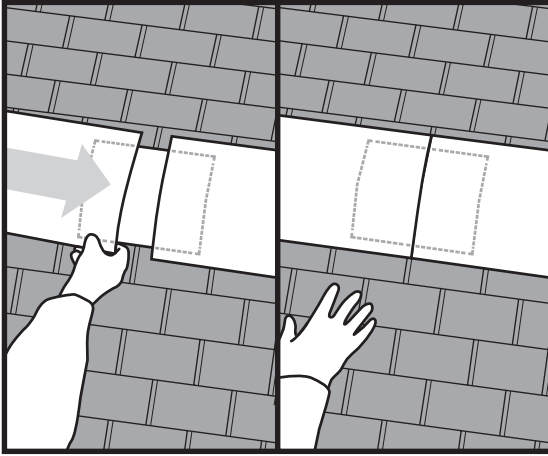

Fig. 5

Step 7: Hip & Ridge Shingle Application

- 1) Hip & ridge shingles should be installed from rake edge to rake edge, starting at the opposite end from which the prevailing winds blow.
- 2) Apply hip & ridge shingles over the ridge vent by centering the shingle over the vent.

Note: When nailing the shingles, ensure that corrosion-resistant, 11 or 12 gauge nails are used with heads at least $\frac{9}{8}$ inch in diameter. All fasteners must be flush with the shingle surface and penetrate $\frac{3}{4}$ inch into the wood deck or $\frac{1}{8}$ inch through APA rated roof sheathing. Hip & ridge shingles should be installed per the shingle manufacturer's installation instructions. See Figure 6.

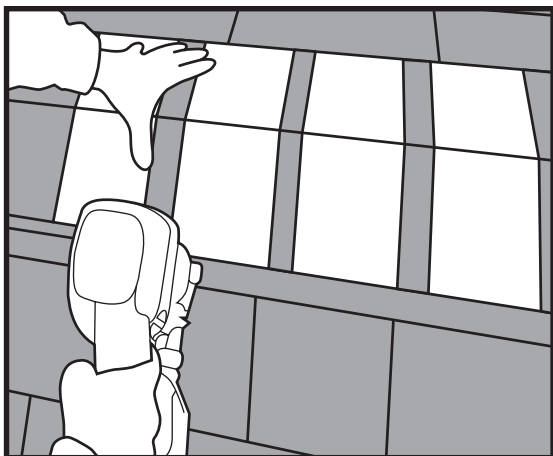

Fig. 6

Note: For installing on roof hips, please call 1-800 GET PINK® (1-800-438-7465) or visit www.owenscorning.com/roofing

VentSure® 4' Strip

Heat & Moisture Ridge Vents

with Weather PROtector Moisture Barrier

VentSure® 4' Strip Ridge Vents are designed for roofs with slopes of 3/12 to 16/12 pitches.

Intake at the eave vents should be equal to or exceed that of the ridge vent being installed. *VentSure* ridge vents are designed for residential applications.

IMPORTANT NOTES:

1. On architectural shingles, roofing cement should be used where the roof vent lower edge meets the laminate shingle to prevent wind-driven rain or snow from blowing under the ridge vent.
2. Before applying vent to architectural shingles on new construction, leave felt long at ridge and fold back under vent or caulk between low areas of shingle and flange of vent, making sure you don't plug holes.
3. See instructions for cutting slot.
4. For structures with different ridge heights, be sure to vent the higher ridge; it is also acceptable to vent lower ridges with dormers.
5. For best appearance, run VentSure® ridge vent from end to end to give the roof a more attractive appearance.
6. For truss rafters, cut a 1¼" slot on each side of the ridge starting a minimum of 6" from the rake edge of the roof. For roofs with a center pole, cut a 1¾" slot on each side of the ridge starting a minimum of 6" from the rake edge of the roof.

Installation Instructions

1. Using a chalk line, mark out 1¼" on both sides of the ridge as a guide for cutting a slot in the top of the ridge. See Fig. 1.

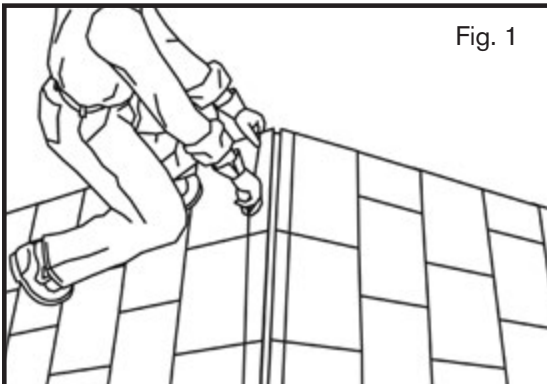
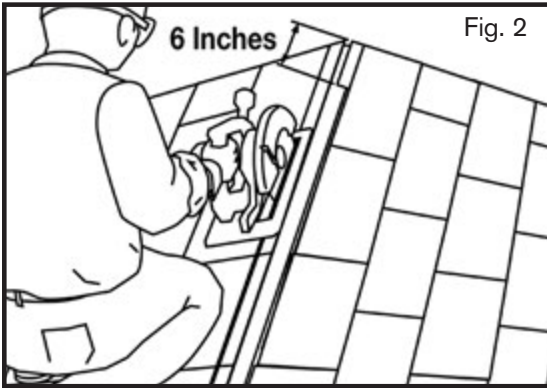

Fig. 1

2. Cut slot using a circular saw with the blade set at a depth to cut through the wood sheathing only. See Fig. 2.



NOTE: Start the cut 6" from the edge of the roof. Remove the sheathing debris from slot.

3. Center the vent over the opening that has been cut in the ridge, ensuring the vent sits flat on the roof. Also ensure that the alignment tabs are facing the opposite direction you will be installing the next piece of ridge vent. See Fig. 3.



4. As you install the vents, ensure each vent is snapped together, then nail in place using the nail holes marked on each vent. See Fig. 4.

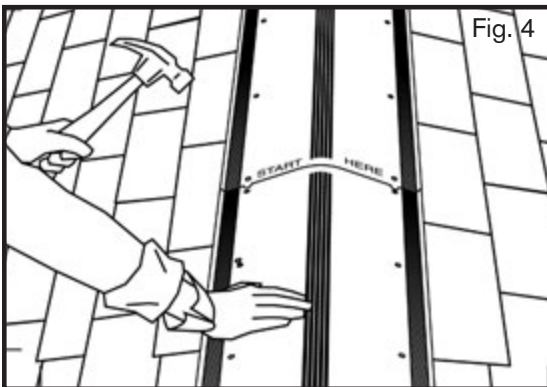

5. Using a utility knife, cut the final piece to a length long enough so that it is flush with the edge of the roof. Connect making sure that the built-in end caps are exposed and nail in place. See Fig. 5.

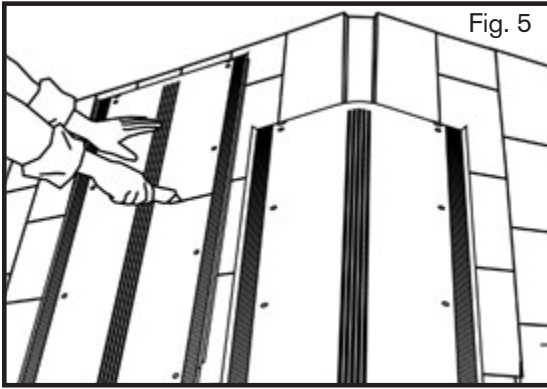

Fig. 5

NOTE: In most cases, the final piece will not use the interlocking feature.

6. Nail hip and ridge shingle over the vent using nails long enough to meet the penetration requirements of the shingle manufacturer or use nails provided with the *VentSure* ridge vent. For a clean look, extend the hip and ridge shingle to cover the interlocking tabs or trim tabs off using a utility knife. See Fig. 6.

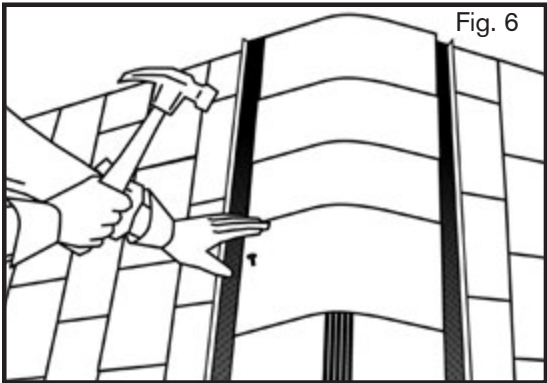

Fig. 6

INSTRUCTIONS FOR CUTTING SLOTS

Hip and Gable Roofs

Cut slot 1¼" on both sides of ridge to within 6" of end wall or hip intersection. See Fig. 7.

VentSure® 4' Strip

Heat & Moisture Ridge Vents

VentSure® 4' Strip Ridge Vents are designed for roofs with slopes of 3/12 to 16/12 pitches.

Intake at the eave vents should be equal to or exceed that of the ridge vent being installed. *VentSure* ridge vent is designed for residential applications.

IMPORTANT NOTES:

1. On architectural shingles, roofing cement should be used where the roof vent lower edge meets the laminate shingle to prevent wind-driven rain or snow to blow under the ridge vent.
2. Before applying vent to architectural shingles on new construction, leave felt long at ridge and fold back under vent or caulk between low areas of shingle and flange of vent, making sure you don't plug holes.
3. See instructions for cutting slot.
4. For structures with different ridge heights, be sure to vent the higher ridge; it is also acceptable to vent lower ridges with dormers.
5. For best appearance, run *VentSure* ridge vent from end to end to give the roof a more attractive appearance.
6. For truss rafters, cut a 1" slot on each side of the ridge starting a minimum of 6" from the rake edge of the roof. For roofs with a center pole, cut a 1½" slot on each side of the ridge starting a minimum of 6" from the rake edge of the roof.

Installation Instructions

1. Using a chalk line, mark out 1" on both sides of the ridge as a guide for cutting a slot in the top of the ridge. See Fig. 1.

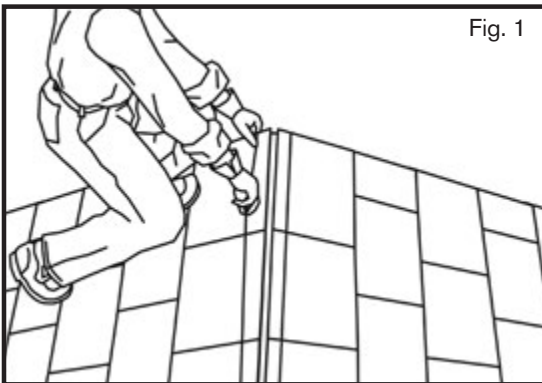

Fig. 1

2. Cut slot using a circular saw with the blade set at a depth to cut through the wood sheathing only. See Fig. 2.



NOTE: Start the cut 6" from the edge of the roof. Remove the sheathing debris from slot.

3. Center the vent over the opening that has been cut in the ridge, ensuring the vent sits flat on the roof. Also ensure that the alignment tabs are facing the opposite direction you will be installing the next piece of ridge vent. See Fig. 3.



4. As you install the vents, ensure each vent is snapped together, then nail in place using the nail holes marked on each vent. See Fig. 4.

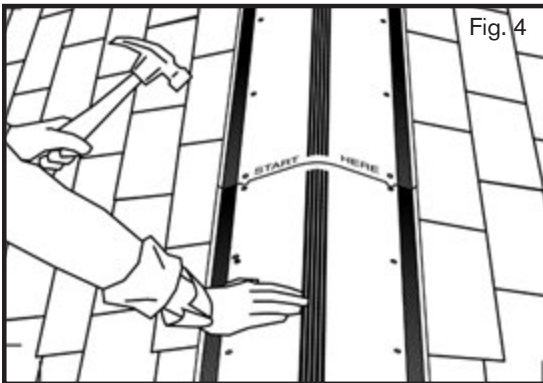

5. Using a utility knife, cut the final piece to a length long enough so that it is flush with the edge of the roof. Connect making sure that the built-in end caps are exposed and nail in place. See Fig. 5.

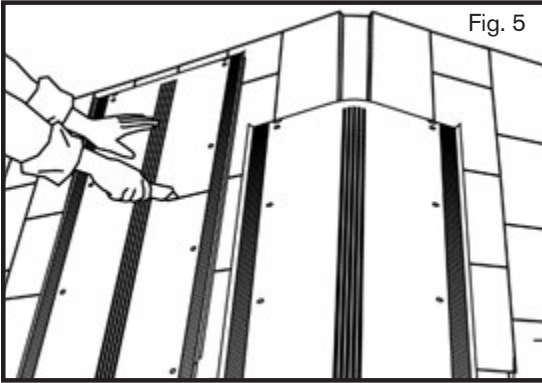

NOTE: In most cases, the final piece will not use the interlocking feature.

6. Nail hip and ridge shingle over the vent using nails long enough to meet the penetration requirements of the shingle manufacturer or use nails provided with the *VentSure* ridge vent. For a clean look, extend the hip and ridge shingle to cover the interlocking tabs or trim tabs off using a utility knife. See Fig. 6.



INSTRUCTIONS FOR CUTTING SLOTS

Hip and Gable Roofs

Cut slot 1" on both sides of ridge to within 6" of end wall or hip intersection. See Fig. 7.

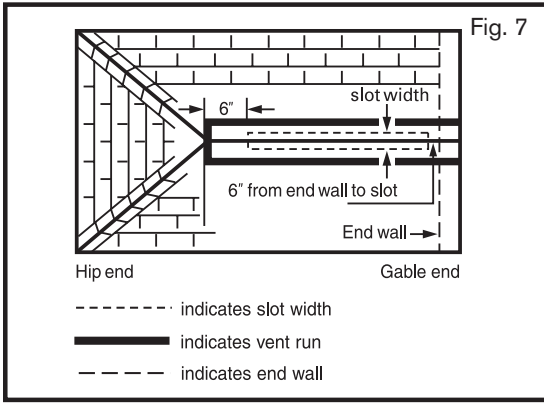

Chimneys

Cut slots 12" from chimney. Run ridge vent from end of roof to butt against chimney. See Fig. 8.

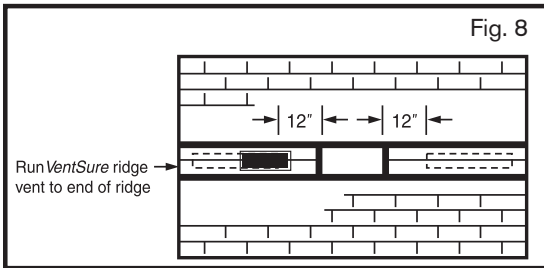

NOTE: Owens Corning's written warranty for this product shall not apply in any instance in which the product was not installed in accordance with the instructions contained herein. See actual warranty for additional warranty details.

LIMITED WARRANTY This product is covered by a Limited Warranty which is available by calling 1-800-GET-PINK® or visiting our Web site at www.owenscorning.com.

THAT WARRANTY CONSTITUTES OUR EXCLUSIVE WARRANTY, AND WE HEREBY DISCLAIM ALL OTHER WARRANTIES, WHETHER EXPRESSED OR IMPLIED, INCLUDING THE IMPLIED WARRANTIES OF MERCHANTABILITY AND FITNESS FOR A PARTICULAR PURPOSE. IN NO EVENT SHALL OWENS CORNING BE LIABLE TO CUSTOMER FOR INCIDENTAL, INDIRECT OR CONSEQUENTIAL DAMAGES.

⚠ WARNING ADVERTENCIA ⚠



Slippery surface, especially when wet or icy. Use a fall protection system when installing. Wear rubber-soled shoes. Walk with care.

Área resbalosa, especialmente cuando está mojada o helada.

Utilice un sistema de protección contra caídas cuando realice la instalación. Use zapatos de hule. Camine con cuidado.

⚠ WARNING ADVERTENCIA ⚠



Sharp edges. Wear gloves when working.

Filos cortantes. Use guantes cuando esté trabajando.

⚠ WARNING ADVERTENCIA ⚠



Falling hazard.

Secure area below work and materials on roof. Unsecured materials may slide on roof. Place on level plane or secure to prevent sliding. Wear a hardhat.

Peligro de objetos que caen.

Por favor asegure el área que se encuentra debajo de la zona de trabajo y amarre los materiales al techo. Los materiales que no estén sujetos pueden resbalarse del techo. Colóquelos en un lugar que no tenga pendiente, o sujételos para prevenir que se resbalen. Use un casco resistente.

Caution: Safety glasses should always be worn when cutting the roof with a power tool.

Precaución: Siempre deben utilizarse anteojos de seguridad al cortar el techo con una herramienta eléctrica.

VentSure® Low Profile Slant Back Roof Vent

Installation Instructions For Owens Corning® VentSure® Low Profile Slant Back Roof Vent

Caution: Roof surface may be slippery, especially when wet or icy. Use a fall precaution system when installing. Wear rubber-soled shoes. Walk with care.

Falling Hazard: Secure area below work and materials on roof. Unsecured materials may slide on roof. Place on level plane or secure to prevent sliding. Wear a hard hat.

1. MARK & CUT

Mark and cut an 11" x 11" hole in the roof deck. (Note: Set blade to thickness of the sheathing.)

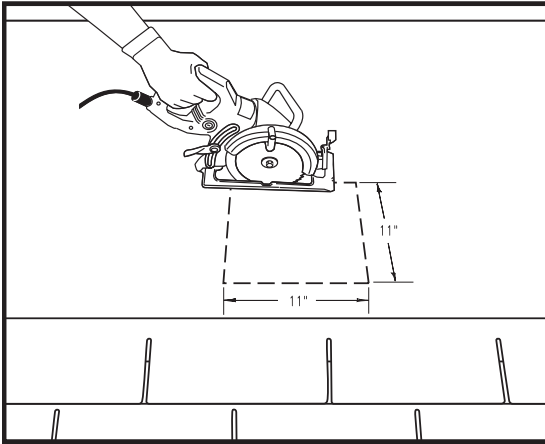

2. SEAL

Seal using sufficient amount of roof cement* around inner and outer flange.

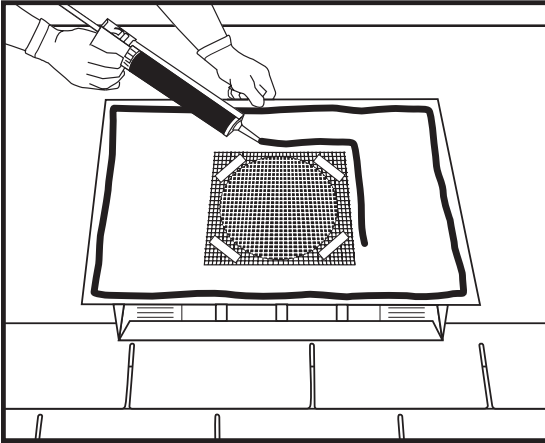

3. PLACE

Place vent directly over the 11" x 11" hole.

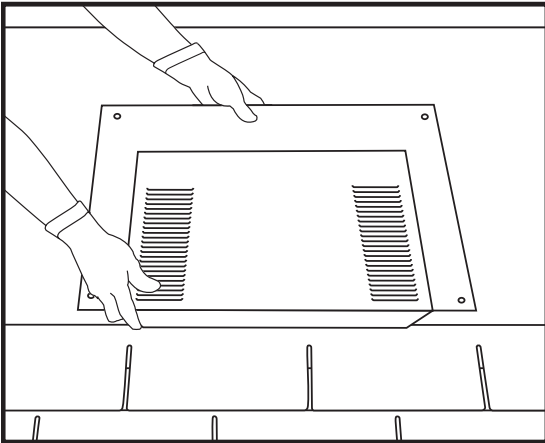

4. SECURE

Secure vent to the roof deck with roofing nails of sufficient length to penetrate $\frac{3}{4}$ " into wood deck or completely through sheathing, spaced approximately 4" on center and 1" from the outside edge of the flange.

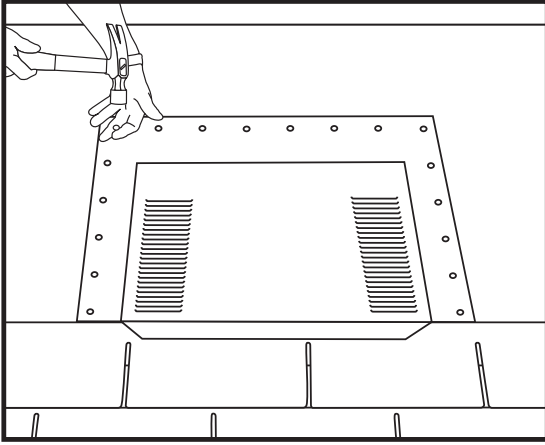

5. COVER

Apply shingles around vent. A 45° angle cut should be made on the material terminating at the vent.

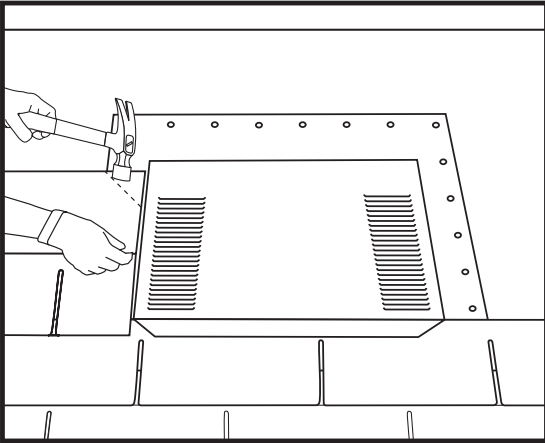

6. TRIM

Cut shingles back 1" on top and sides of vent cover to allow for proper drainage.

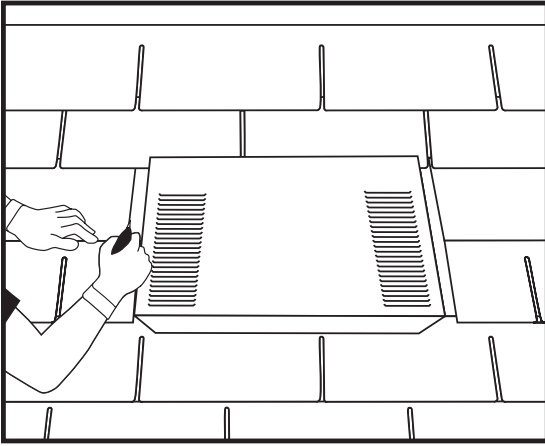

* MEETS ASTM D4586

For more information regarding snow and high velocity wind applications contact Owens Corning at 1-800-GET-PINK®.

VentSure® Plastic Slant Back Roof Vent



Product Benefits:

- Allows outside air to flow naturally upward and out of attic.
- Promotes a cooler, drier attic.
- Helps prevent moisture from being trapped in insulation, structural wood, shingles and roof deck.
- Helps prevent rotting, mildew, drywall damage, peeling paint and warped siding.
- Helps increase the performance of your roof.
- Works year-round for consistent ventilation without energy consumption.

Application

Required Ventilation:

- As a general rule, one square foot of net free vent area per 300 square feet of attic floor or area to be vented is recommended.
- In the rare situation where no vapor retarder is used and/or proper distribution of soffit and ridge vents cannot be achieved, one square foot of net free vent area should be provided for each 150 square feet of attic floor or area to be vented.
- For a balanced system, ventilation should be equal at the undereave and ridge.
- In cases where a balanced system cannot be achieved, always provide more than 50% of the total required ventilation at the undereave and the remainder at the upper portion of the roof.

Installation

1. Place the unit on top of the roof approximately 24" from the top of the ridge. For neat installation, the low profile housing on the unit should be visible only on one side of the roof. When this position is established, locate a centerline

directly between two rafters and drill a hole through the roof, from the inside. This hole will be used as a center for the following operations.

2. Draw a circle or square on the roof (refer to chart for opening size), using the drilled hole as the center, and cut the appropriate size hole in the roof. See Figure 1.

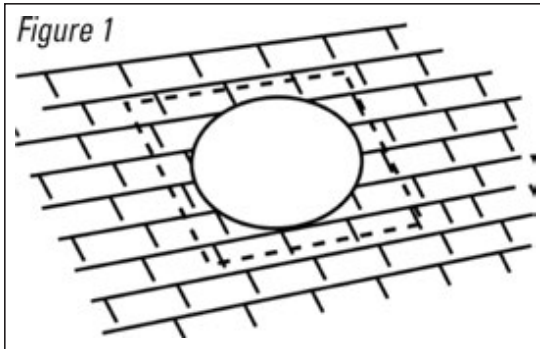

3. With the top of the unit parallel to the ridge line, slide the flange up under the shingles. When installing over an existing roof it may be necessary to remove some additional roofing material and fasteners around the vent for it to fit snugly. See Figure 2. Use roof cement between the flange and shingles approximately $\frac{1}{2}$ " from the outer edge. Secure with roofing nails long enough to penetrate $\frac{3}{4}$ " into the wood deck or completely through plywood sheathing with a maximum 4" space between each nail. See Figure 3.

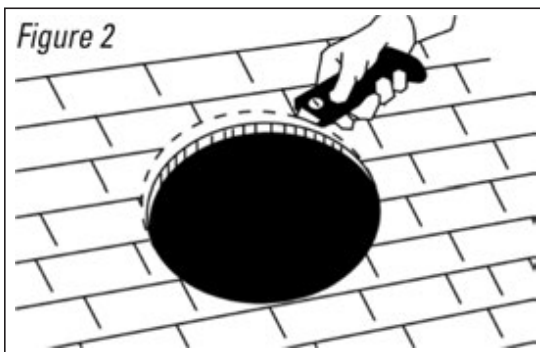
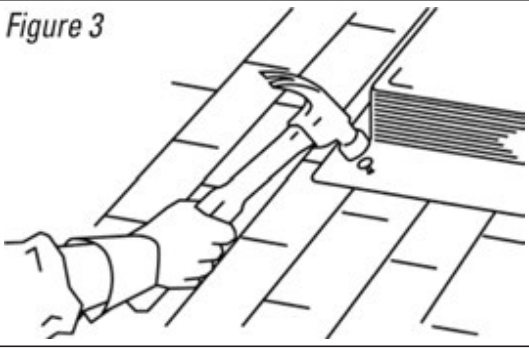

Figure 3



Vent illustrations do not necessarily reflect the individual product style.

Product Specifications

MODEL NAME	COLOR	LONG CODE	SHORT CODE	PCS/ CTN	CTNS/ PAL	PALLETS/ TRUCK	BASE	OPENING	SLOPE	NFVA SQ. IN.	NFVA SQ. FT.
PLASTIC SLANT BACK	GREY	525815	PLSBGR	12	15	24	17"x18"	9"x9"	3/12"-12/12"	55	0.38
PLASTIC SLANT BACK	BLACK	525816	PLSBBL	12	15	24	17"x18"	9"x9"	3/12"-12/12"	55	0.38
PLASTIC SLANT BACK	BROWN	525818	PLSBBR	12	15	24	17"x18"	9"x9"	3/12"-12/12"	55	0.38
PLASTIC SLANT BACK	WEATHERED GREY	525819	PLSBWG	12	15	24	17"x18"	9"x9"	3/12"-12/12"	55	0.38
PLASTIC SLANT BACK	CEDAR	525820	PLSBCE	12	15	24	17"x18"	9"x9"	3/12"-12/12"	55	0.38
PLASTIC SLANT BACK	WHITE	525821	PLSBWH	12	15	24	17"x18"	9"x9"	3/12"-12/12"	55	0.38

VentSure® Metal Dome Roof Vent



Product Benefits:

- Allows outside air to flow naturally upward and out of attic.
- Promotes a cooler, drier attic.
- Helps prevent moisture from being trapped in insulation, structural wood, shingles and roof deck.
- Helps prevent rotting, mildew, drywall damage, peeling paint and warped siding.
- Helps increase the performance of your roof.
- Works year-round for consistent ventilation without energy consumption.

Application

Required Ventilation:

- As a general rule, one square foot of net free vent area per 300 square feet of attic floor or area to be vented is recommended.
- In the rare situation where no vapor retarder is used and/or proper distribution of soffit and ridge vents cannot be achieved, one square foot of net free vent area should be provided for each 150 square feet of attic floor or area to be vented.
- For a balanced system, ventilation should be equal at the undereave and ridge.
- In cases where a balanced system cannot be achieved, always provide more than 50% of the total required ventilation at the undereave and the remainder at the upper portion of the roof.

Installation

1. Place the unit on top of the roof approximately 24" from the top of the ridge. For neat installation, the low profile housing on the unit should be visible only on one side of the roof. When this position is established, locate a centerline directly between two rafters and drill a hole through the roof, from the inside. This hole will be used as a center for the following operations.
2. Draw a circle or square on the roof (refer to chart for opening size), using the drilled hole as the center, and cut the appropriate size hole in the roof. See Figure 1.

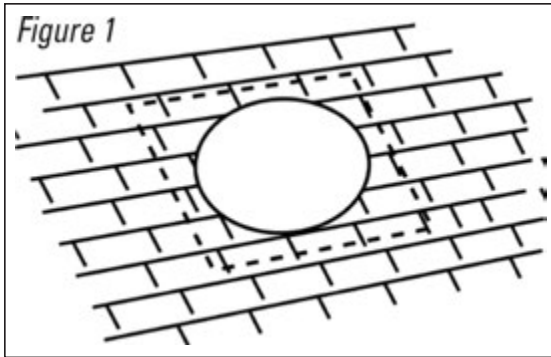

3. With the top of the unit parallel to the ridge line, slide the flange up under the shingles. When installing over an existing roof it may be necessary to remove some additional roofing material and fasteners around the vent for it to fit snugly. See Figure 2. Use roof cement between the flange and shingles approximately $\frac{1}{2}$ " from the outer edge. Secure with roofing nails long enough to penetrate $\frac{3}{4}$ " into the wood deck or completely through plywood sheathing with a maximum 4" space between each nail. See Figure 3.

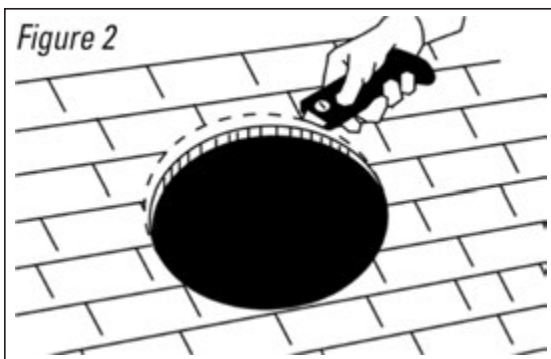
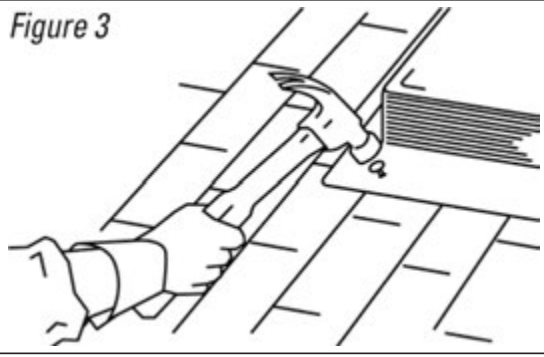

Figure 3



Vent illustrations do not necessarily reflect the individual product style.

Product Specifications

	MODEL NAME	COLOR	LONG CODE	SHORT CODE	PCS/ CTN	CTNS/ PAL	PALLETS/ TRUCK	BASE	OPENING	SLOPE	NFVA SQ IN.	NFVA SQ FT.
GALVANIZED	GALVANIZED METAL DOME	MILL	525811	GVDMLL	1	30	24	25"x25"	15"	3/12"-8/12"	144	1.00
	GALVANIZED METAL DOME	BROWN	525812	GVDMBR	1	30	24	25"x25"	15"	3/12"-8/12"	144	1.00
	GALVANIZED METAL DOME	BLACK	525813	GVDMBL	1	30	24	25"x25"	15"	3/12"-8/12"	144	1.00
	GALVANIZED METAL DOME	WEATHERED GREY	525814	GVDMWG	1	30	24	25"x25"	15"	3/12"-8/12"	144	1.00

VentSure® Square Top Roof Vent



Product Benefits:

- Allows outside air to flow naturally upward and out of attic.
- Promotes a cooler, drier attic.
- Helps prevent moisture from being trapped in insulation, structural wood, shingles and roof deck.
- Helps prevent rotting, mildew, drywall damage, peeling paint and warped siding.
- Helps increase the performance of your roof.
- Works year-round for consistent ventilation without energy consumption.

Application

Required Ventilation:

- As a general rule, one square foot of net free vent area per 300 square feet of attic floor or area to be vented is recommended.
- In the rare situation where no vapor retarder is used and/or proper distribution of soffit and ridge vents cannot be achieved, one square foot of net free vent area should be provided for each 150 square feet of attic floor or area to be vented.
- For a balanced system, ventilation should be equal at the under-eave and ridge.
- In cases where a balanced system cannot be achieved, always provide more than 50% of the total required ventilation at the under-eave and the remainder at the upper portion of the roof.

Installation

1. Place the unit on top of the roof approximately 24" from the top of the ridge. For neat installation, the low profile housing on the unit should be visible only on one side of the roof. When this position is established, locate a centerline

directly between two rafters and drill a hole through the roof, from the inside. This hole will be used as a center for the following operations.

2. Draw a circle or square on the roof (refer to chart for opening size), using the drilled hole as the center, and cut the appropriate size hole in the roof. See Figure 1.

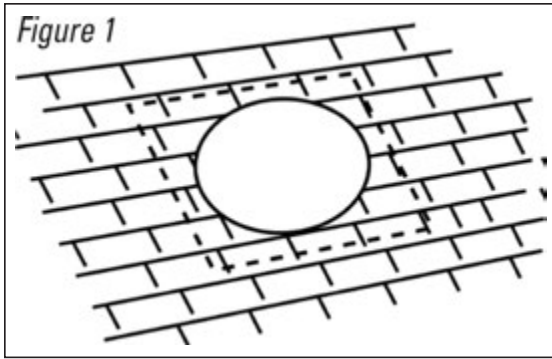

3. With the top of the unit parallel to the ridge line, slide the flange up under the shingles. When installing over an existing roof it may be necessary to remove some additional roofing material and fasteners around the vent for it to fit snugly. See Figure 2. Use roof cement between the flange and shingles approximately $\frac{1}{2}$ " from the outer edge. Secure with roofing nails long enough to penetrate $\frac{3}{4}$ " into the wood deck or completely through plywood sheathing with a maximum 4" space between each nail. See Figure 3.

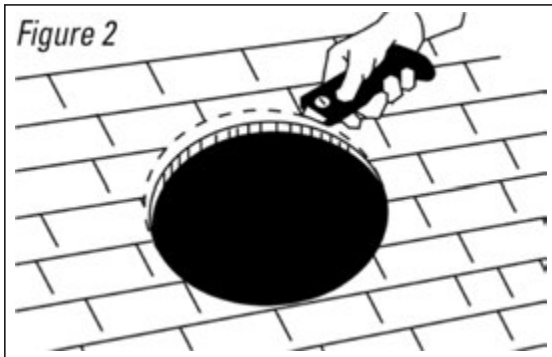
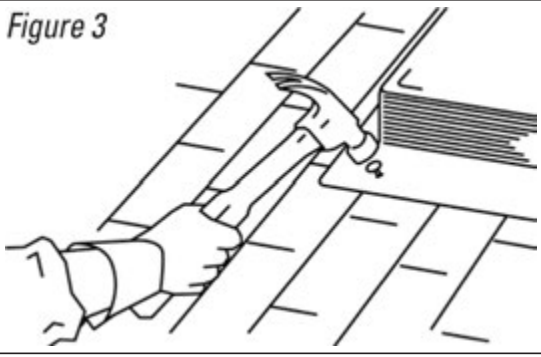

Figure 3



Vent illustrations do not necessarily reflect the individual product style.

Product Specifications

	MODEL NAME	COLOR	LONG CODE	SHORT CODE	PGS/ CTN	CTNS/ PALLETS/ TRUCK	BASE	OPENING	SLOPE	NFVA SQ. IN.	NFVA SQ. FT.	
ALUMINUM	ALUMINUM SQUARE TOP	MILL	525844	ALSTML	6	20	28	16.5"x17.5"	8"x8"	3/12"-6/12"	51	0.35
	ALUMINUM SQUARE TOP	BROWN	525846	ALSTBR	6	20	28	16.5"x17.5"	8"x8"	3/12"-6/12"	51	0.35
	ALUMINUM SQUARE TOP	BLACK	525845	ALSTBL	6	20	28	16.5"x17.5"	8"x8"	3/12"-6/12"	51	0.35
	ALUMINUM SQUARE TOP	WEATHERED GREY	525847	ALSTWG	6	20	28	16.5"x17.5"	8"x8"	3/12"-6/12"	51	0.35
GALVANIZED	GALVANIZED SQUARE TOP	MILL	525848	GVSTML	6	20	28	16.5"x17.5"	8"x8"	3/12"-6/12"	51	0.35
	GALVANIZED SQUARE TOP	BROWN	525850	GVSTBR	6	20	28	16.5"x17.5"	8"x8"	3/12"-6/12"	51	0.35
	GALVANIZED SQUARE TOP	BLACK	525849	GVSTBL	6	20	28	16.5"x17.5"	8"x8"	3/12"-6/12"	51	0.35
	GALVANIZED SQUARE TOP	WEATHERED GREY	530646	GVSTWG	6	20	28	16.5"x17.5"	8"x8"	3/12"-6/12"	51	0.35

VentSure® High Profile Slant Back Roof Vent

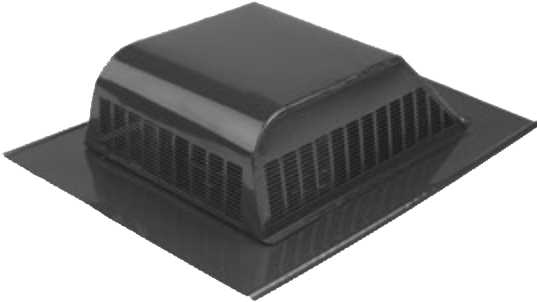

Product Benefits:

- Allows outside air to flow naturally upward and out of attic.
- Promotes a cooler, drier attic.
- Helps prevent moisture from being trapped in insulation, structural wood, shingles and roof deck.
- Helps prevent rotting, mildew, drywall damage, peeling paint and warped siding.
- Helps increase the performance of your roof.
- Works year-round for consistent ventilation without energy consumption.

Application

Required Ventilation:

- As a general rule, one square foot of net free vent area per 300 square feet of attic floor or area to be vented is recommended.
- In the rare situation where no vapor retarder is used and/or proper distribution of soffit and ridge vents cannot be achieved, one square foot of net free vent area should be provided for each 150 square feet of attic floor or area to be vented.
- For a balanced system, ventilation should be equal at the undereave and ridge.
- In cases where a balanced system cannot be achieved, always provide more than 50% of the total required ventilation at the undereave and the remainder at the upper portion of the roof.

Installation

1. Place the unit on top of the roof approximately 24" from the top of the ridge. For neat installation, the low profile housing on the unit should be visible only on one side of the roof. When this position is established, locate a centerline directly between two rafters and drill a hole through the roof, from the inside.

This hole will be used as a center for the following operations.

2. Draw a circle or square on the roof (refer to chart for opening size), using the drilled hole as the center, and cut the appropriate size hole in the roof. See Figure 1.

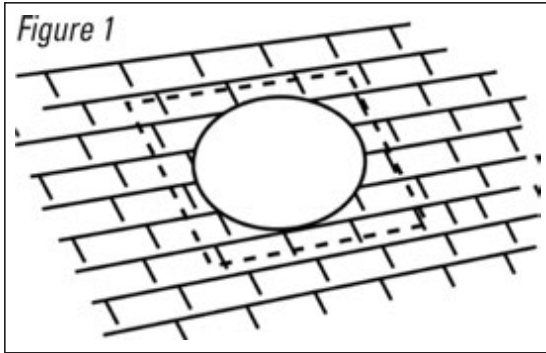

3. With the top of the unit parallel to the ridge line, slide the flange up under the shingles. When installing over an existing roof it may be necessary to remove some additional roofing material and fasteners around the vent for it to fit snugly. See Figure 2. Use roof cement between the flange and shingles approximately $\frac{1}{2}$ " from the outer edge. Secure with roofing nails long enough to penetrate $\frac{3}{4}$ " into the wood deck or completely through plywood sheathing with a maximum 4" space between each nail. See Figure 3.

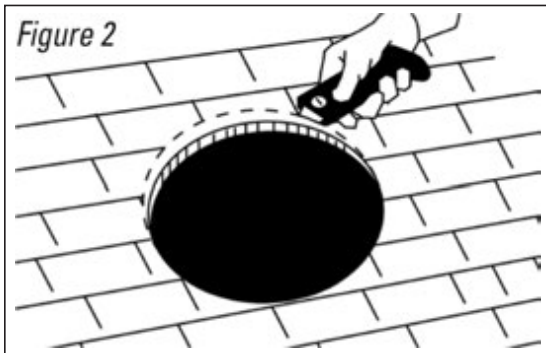
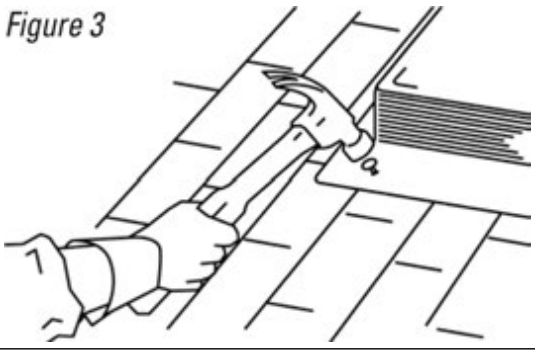

Figure 3



Vent illustrations do not necessarily reflect the individual product style.

Product Specifications

	MODEL NAME	COLOR	LONG CODE	SHORT CODE	PCS/ CTN	CTNS/ PAL	PALLETS/ TRUCK	BASE	OPENING	SLOPE	NFVA SQ IN.	NFVA SQ FT.
ALUMINUM	ALUMINUM SLANT BACK	MILL	525825	ALSBML	6	20	26	16"x20"	8"	3/12"-12/12"	51	0.35
	ALUMINUM SLANT BACK	BROWN	525826	ALSBBR	6	20	26	16"x20"	8"	3/12"-12/12"	51	0.35
	ALUMINUM SLANT BACK	BLACK	525827	ALSBBL	6	20	26	16"x20"	8"	3/12"-12/12"	51	0.35
	ALUMINUM SLANT BACK	WEATHERED GREY	525828	ALSBBG	6	20	26	16"x20"	8"	3/12"-12/12"	51	0.35
GALVANIZED	GALVANIZED SLANT BACK	MILL	525829	GVSBML	6	20	26	16"x20"	8"	3/12"-12/12"	51	0.35
	GALVANIZED SLANT BACK	BROWN	525832	GVSBBR	6	20	26	16"x20"	8"	3/12"-12/12"	51	0.35
	GALVANIZED SLANT BACK	BLACK	525831	GVSBBL	6	20	26	16"x20"	8"	3/12"-12/12"	51	0.35
	GALVANIZED SLANT BACK	WEATHERED GREY	525843	GVSBBG	6	20	26	16"x20"	8"	3/12"-12/12"	51	0.35

VentSure® Rigid Roll Ridge Vent

with Weather PROtector Moisture Barrier

What are the advantages of VentSure® Rigid Roll Ridge Vents with Weather PROtector® Moisture Barrier?

- Patented, lightweight, high-density polypropylene construction
- Advanced moisture barrier— no baffles required
- Only 5/8" vent profile
- 20-foot roll is easy to handle and ready to install
- Adjusts to almost any roof pitch (2/12 to 20/12 pitch)*
- Easy to transport and handle
- Rounded peak reduces shingle stress and cracking
- Can be installed with a nail gun
- Won't compress when nailed
- Won't clog or deteriorate like other vents

What materials are required to install a VentSure® Rigid Roll Ridge Vent with Weather PROtector® Moisture Barrier ventilation system?

- VentSure® rigid roll ridge vent with Weather PROtector® moisture barrier
- End cap (included in package)
- Roofing nails
- Construction adhesive or sealant caulk

What tools are required to install a VentSure® Rigid Roll Ridge Vent with Weather PROtector® Moisture Barrier ventilation system?

- Safety goggles
- Utility knife
- Tape measure
- Power saw
- Coil nailer or hammer

What installation precautions should I follow?

- Read all instructions before proceeding
- Always wear safety goggles
- Follow all standard safety precautions

What general ventilation tips should I know?

- Do not allow insulation to block undereave vents
- For proper ventilation, adequate intake is necessary to prevent back drafts and assure effectiveness of ridge vent system

*Refer to local building codes for roof pitch requirements.

- Close off all gable and other roof vent openings
- Do not allow air from home appliances (dryers, range hoods, bathroom fans, etc.) to exhaust into attic—exhaust directly to outdoors

How much ridge/undereave ventilation is required?

In order for your ventilation system to operate properly, a system must be designed to create an airflow that draws air out of the attic at the roof peak and brings air into the attic along the underside of the roof. This can be accomplished by using VentSure® rigid roll ridge vents with Weather PROtector® moisture barrier, which allow air to be drawn out of the attic (exhaust), and soffit vents, which allow air into the attic (intake).

For maximum efficiency, and to create what is considered a balanced system, ventilation should be equal at the soffit and ridge. It is critical to provide proper distribution of ridge and soffit vents. In cases where a balanced system cannot be achieved, always provide more than 50 percent of the total required ventilation at the soffit and the remainder at the ridge. Again, the desired system is to equalize ventilation at both the soffit and ridge areas.



To calculate the minimum amount of total ventilation required, use either the 1/300 or 1/150 ratio. On the inside, the actual calculations have been made for your convenience. Use the 1/300 ratio if you have proper distribution of soffit and ridge vents or if a vapor retarder is present. Use the 1/150 ratio if proper distribution of soffit and ridge vents cannot be achieved and a vapor retarder is not present.

See the chart on the back page to identify the minimum amount of ridge and soffit ventilation required. Always remember that proper distribution will result in exhaust (ridge vent) and intake (soffit vent). For the best results, run the VentSure® rigid roll ridge vent with Weather PROtector® moisture barrier along the entire peak of the roof in accordance with these application instructions.

The Net Free Vent Area (NFVA) of soffit ventilation should always be at least equal to or more than the net free vent area of the ridge ventilation.

Where can VentSure® rigid roll ridge vents with Weather PROtector® moisture barrier be installed?

Chimney on Roof

- Saw slots to within 12" of any chimney located on ridge as shown and butt ridge vent flush against chimney

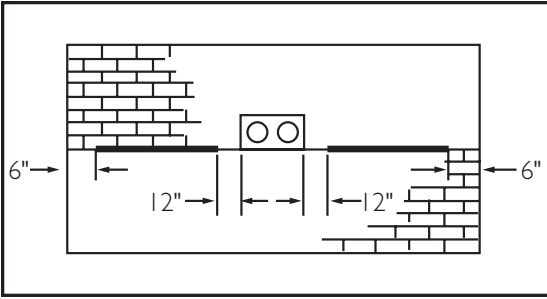

Hip Roof

- Saw slot on center of ridge to within 6" of each end as shown
- Run ridge vent across complete length of ridge

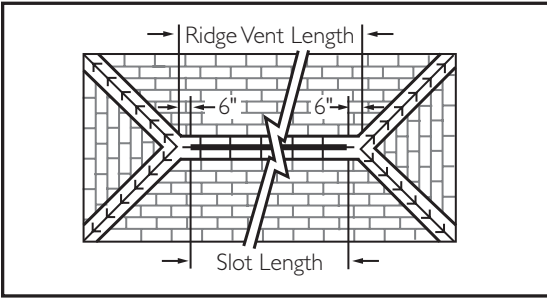

"T" & "L" Roof

- Saw slots to within 12" of ridge intersection points as shown
- Install ridge vent completely across ridge on long side and butt ridge vent on the short run against the side of the long run

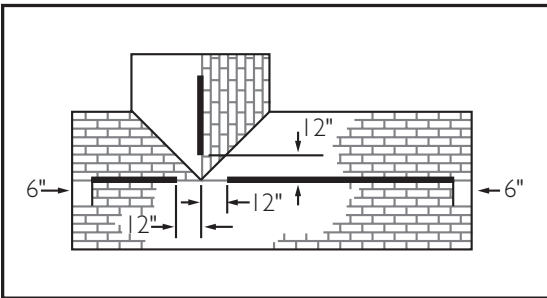

Installation Instructions for VentSure® Rigid Roll Ridge Vent with Weather PROtector® Moisture Barrier

Step I. Hip and Ridge Ventilation Slot Preparation

Determine how long of a hip and ridge ventilation slot will be required according to 1/300 rule. The ridge and hip ventilation slot may be pre-cut on a new roof before or after shingle installation or in a retrofit, the slot can be cut from the pre-

shingled roof using a circular saw with a carbide tip blade. (Protective eye goggles should be worn during this process). Start ridge ventilation slot 6" from point where hip and ridge meet. Cut a 2" slot (1" on each side of ridge) along the ridge(s). For a roof with a center beam, a 3½" slot should be cut (1¾" on each side of ridge). If entire ridge requires ventilation, stop ventilation slot 6" from point where hip and ridge meet. To maintain structural integrity, one continuous slot is not recommended on hip applications. Start ventilation preparation by leaving 6" of hip uncut from where the ridge and hip meet. Cut a 3½" width slot for ventilation. Hip slot should be 18" in length, spaced with a 12" uncut area between each 18" opening. The slot for ventilation should not be cut any lower than the top ⅓ of the roof to maintain a balanced ventilation system.

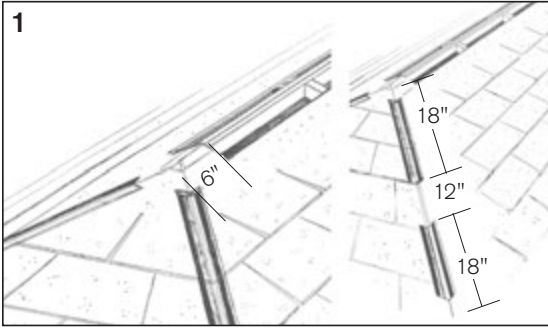

Step 2. Vent Placement on Ridge

Roll out or place VentSure® rigid roll ridge vents with Weather PROtector® moisture barrier along the entire length of slot also covering the 6" minimum uncut ridge on both ends. Multiple lengths of vent can be joined by butting the sections tightly together. Products with VentSure® rigid roll with Weather PROtector® moisture barrier should have an end cap inserted at the end of each section. (See Step #3)

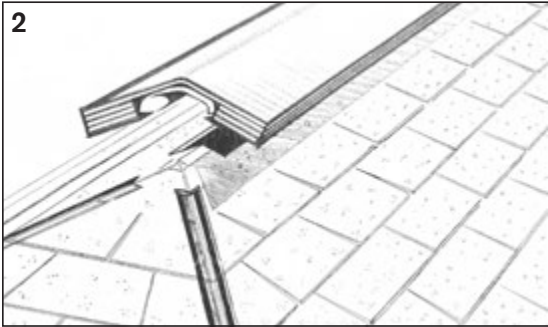

Step 3. End Cap Installation

Install the end caps. Pull apart a pre-cut section of the foam end cap packaged with the vent. For products with VentSure® Rigid Roll with Weather PROtector®, using a utility knife, make a cut in the VentSure® rigid roll with Weather PROtector® material on each side of the vent, back from the end of the roll. (See

Fig. 3 inset). Using construction adhesive or sealant caulk, coat both sides of the foam material to ensure a proper seal. Place the foam end cap on top of the VentSure® rigid roll ridge vents with Weather PROtector® material where it has been cut back at the end of the vent. (See illustration #3). Attach vent to the roof deck by driving a nail in each of the two corners on both ends of the vent. Also, drive two nails through the vent and foam end cap to hold foam in place on the ends of the ridge only. Nails should penetrate the wood roof deck at least 3/4" into the deck, where the deck is less than 3/4" thick the fastener should be long enough to penetrate fully and extend at least 1/8" through the roof deck. It is important when installing this vent that you maintain the pitch of the roof. The vent has been installed properly if the bottom of the vent is flat on the roof and the peak is slightly rounded.

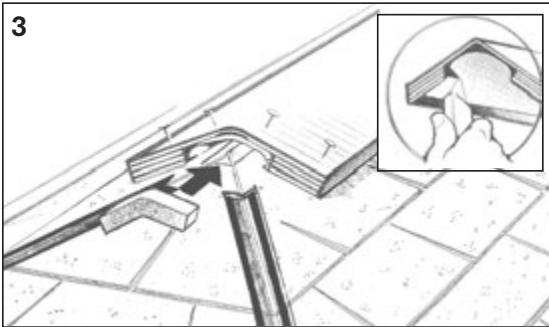

Note: For “Class A” Installation Only

For Class A, VentSure® rigid roll ridge vents with Weather PROtector® moisture barrier installation follow steps 1, 2, 3 as stated above. Once the vent has been installed, use a Utility knife with a hook blade and remove the corrugated plastic center section of the vent. (See Fig 3B) Do this for the Hip and the Ridge. This modified installation meets the requirements for UL790 Class A, standard installation meets the requirements for UL790 Class C. Follow remaining steps 4, 5, 6 as stated.

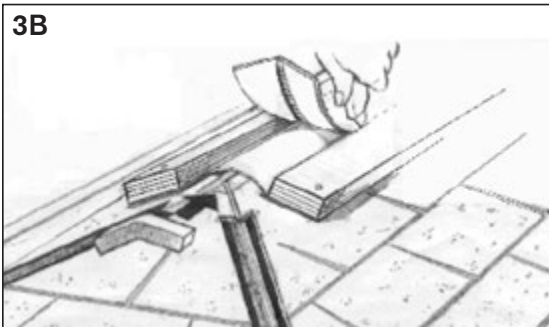

Step 4. Vent Placement on Hip

Install a minimum of two Hip & Ridge shingles at the bottom of the hip. If the VentSure® rigid roll ridge vent with Weather PROtector® moisture barrier is not

being run the entire length of the hip, the vent should overlap a minimum of two Hip & Ridge shingles at the end of the vent. Before installing the vent on the hip, lay a bead of sealant on each side of the pre-cut slots. This will create a seal on the step created by overlapping pattern of the shingles. The bead of sealant should be applied approximately 1" from the edge of the pre-cut slot.

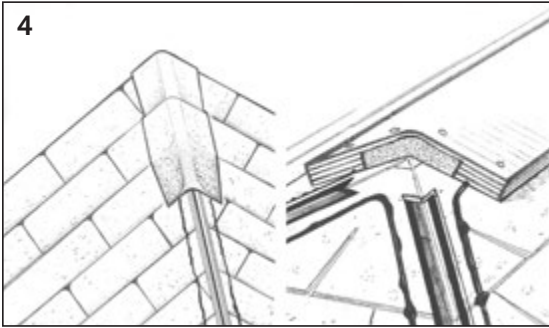

Step 5. Hip and Ridge Vent Transition

Using a utility knife, trim the end of VentSure® rigid roll ridge vent with Weather PROtector® moisture barrier from the hip to the ridge. This creates the most attractive ridge and hip line. Insert the foam end cap under the VentSure® rigid roll ridge vent with Weather PROtector® moisture barrier where it is at full width. Fasten vent for hip at point where it meets ridge. Roll out or place the vent all of the way down the hip, covering two pre-laid cap shingles at the bottom of the hip. Go back over hip vents and fasten at 4" intervals.

If the VentSure® rigid roll ridge vent with Weather PROtector® moisture barrier is not being run the entire length of the hip, use the cap shingles to create a transition. Use sealant to fill any void left between the shingles and the remaining top layer of the vent. Be sure to apply roofing sealant to any spaces left by cap shingle used for transition. If two or more sections of VentSure® rigid roll ridge vent with Weather PROtector® moisture barrier are being joined together, an end cap MUST be installed into each end of the joining sections. (See Fig. 3 for end cap installation). Repeat on all hips.



Step 6. Cap Shingle Installation

Apply the Hip and Ridge shingles to the hip and then to the ridge. Nail hip and ridge shingles with roofing nails in a common overlapping pattern. All fasteners must be driven flush with the shingle surface and penetrate at least $\frac{3}{4}$ " in to the wood deck, where the deck is less than $\frac{3}{4}$ " thick the fastener should be long enough to penetrate fully and extend at least $\frac{1}{8}$ " through the roof deck. It is important when installing this vent that you maintain the pitch of the roof. The vent has been installed properly if the bottom of the vent is flat on the roof and the peak is slightly rounded.

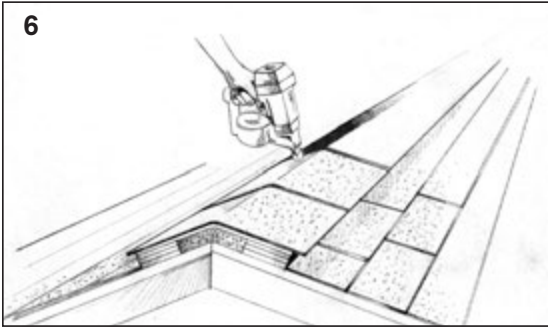

Specifications

Product: VentSure® Rigid Roll Ridge Vents with Weather PROtector® Moisture Barrier

Material: High-density polypropylene

Color: Black

Widths: 7", 9" and 11¼"

Length: 20-foot roll

Net Free Area: 12.5 square inches per lineal foot

Accessories: Foam end caps

VentSure® rigid roll ridge vent with Weather PROtector® moisture barrier, when properly installed with soffit or eave vents, meets or exceeds the requirements of all recognized national building codes for ventilation. VentSure® rigid roll ridge vent with Weather PROtector® moisture barrier was tested in research and development and passed all tests for weather infiltration. Testing was performed at Architectural Testing Incorporated (ATI) in York, PA.

Wind-Driven Rain—8.8 inches of rain at 110 MPH—Passed.

Snow Infiltration—Snow simulation at 35 and 70 MPH—Passed with no infiltration.

Ventilation Table: 1/150 Ratio

Attic Square Footage	Square Inches NFVA at Ridge	Min. Feet of Rigid Roll Ridge Vent	Min. Square Inches NFVA at Soffits
1000	480	38	480
1100	528	42	528
1200	576	46	576
1300	624	50	624
1400	672	54	672
1500	720	58	720
1600	768	61	768
1700	816	65	816
1800	864	69	864
1900	912	73	912
2000	960	77	960
2100	1008	81	1008
2200	1056	84	1056
2300	1104	88	1104
2400	1152	92	1152

Use this table if proper distribution of soffit and ridge vents cannot be achieved and a vapor retarder is not present.

Ventilation Table: 1/300 Ratio

Attic Square Footage	Square Inches NFVA at Ridge	Min. Feet of Rigid Roll Ridge Vent	Min. Square Inches NFVA at Soffits
1000	240	19	240
1100	264	21	264
1200	288	23	288
1300	312	25	312
1400	336	27	336
1500	360	29	360
1600	384	31	384
1700	408	33	408
1800	432	35	432
1900	456	36	456
2000	480	38	480
2100	504	40	504
2200	528	42	528
2300	552	44	552
2400	576	46	576

Use this table if you have proper distribution of soffit and ridge vents or a vapor

Note: The above tables are based on minimum FHA vent requirements to meet building codes.

VentSure® Solar Attic Exhaust Fan - Roof Mount Kit

This fan is designed for new or re-roofing work over any properly built and supported wood roof deck having adequate nail holding capacity, a smooth surface, and a roof slope of 4:12 or greater.

Before installing this product, check local building codes for their roofing requirements.

The manufacturer will not be responsible for problems resulting from any deviation from the recommended application instructions.

TOOLS REQUIRED

- Ladder
- Reciprocating saw or jig saw
- Power drill with a 1/2"-1" drill bit (only one needed)
- Hammer and roofing nail
- Caulk Gun with ASTM D 4586 Type I Asphalt Roofing Cement
- Measuring tape or ruler
- Permanent marker, sidewalk chalk or colored pencil
- Roofing knife or box cutter
- Flat pry bar
- Phillips Screwdriver

Box Contents



Precautionary Notes

Safety Tips

- Complete all roof preparation prior to bringing the solar fan onto the roof.
- Keep the solar panel covered until after installation. Exposing the solar panel to the sun will start the fan blades rotating which could cause bodily injury.

Roof Deck

- Maximum 6" width 25/32" minimum thickness of wood sheathing
- Minimum 3/8" plywood sheathing or 7/16" OSB
- Sheathing spaced minimum 1/8" and maximum 1/4"
- Check local building codes or use decking recommended by American Plywood Association

Ventilation Requirements

- Ventilation must meet or exceed Federal Housing Administration minimum property standard.
- Before beginning the installation, calculate the square feet of attic space being ventilated and select the recommended number of *VentSure* Solar Attic Exhaust Fans necessary for moving the required CFM (cubic feet per minute). Depending on the size of attic space to be ventilated, more than 1 solar fan may be required. See Fan Sizing Chart below.
- It is critical to ensure there is proper intake ventilation at the eave or fascia. For each Roof Mount fan, Owens Corning requires 600 sq. in. of intake.

Note: If it isn't practical to achieve the required amount of intake ventilation, Owens Corning recommends adequately sealing the attic floor and any HVAC ducts in the attic to prevent pulling air from conditioned space.

- Some attics have more than one walled off or chambered area. This situation will require fans for each area.
- To maximize the solar fan's effectiveness you should remove or block any rooftop static vents, gable end vents, or ridge vents. This can be accomplished using any roofing underlayment, ensuring it is securely attached. (Figures 2 and 3)



Figure 2



Figure 3

Positioning

- The solar fan should be positioned to face south or southwest for optimum performance and should be positioned on an area of the roof that is not shaded or blocked from the sun for extended periods throughout the day.
- The solar fan should be installed 18-24" from the ridge of the roof and as close to mid-point of the house as possible. (Figure 4)
- In the event 2 or more fans are being installed, separate the fans by at least 15 feet to optimize ventilation.

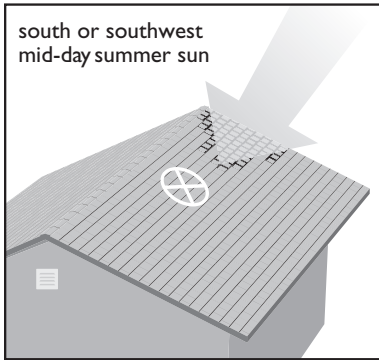

Figure 4

Fan Sizing Chart			
Attic Size (Sq. Ft.)	Number of Roof Mount Fans Required		
	Low Slope 3:12–4:12	Medium Slope 5:12–8:12	Steep Slope 9:12–12:12
1,200	1	1	1
1,600	1	1	2
2,000	1	1	2
2,400	1	2	2
2,800	1	2	3

Installation

Step 1. Marking the Installation Hole

- From inside the attic measure down from the roof peak 18-24" and center this spot between 2 rafters. (Figures 5 and 6)

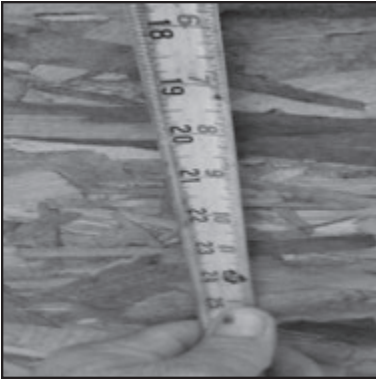

Figure 5

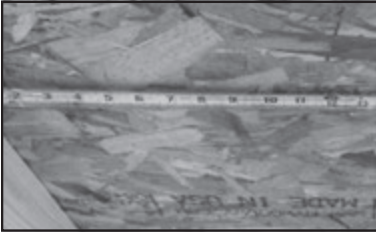

Figure 6

- Make sure there are no wires or waterlines in the area to be cut.
- Drive a nail through this mark into the roof deck and through the shingles so that it can be easily found on the top of the roof. (Figure 7)



Figure 7

- Locate the nail protruding through the roof and place one of the holes in the template over the nail shank. (Figure 8)

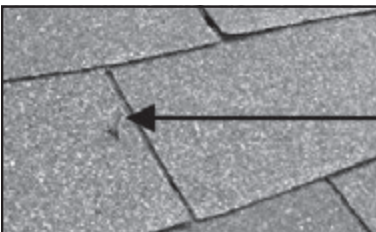

Figure 8

- With a colored pencil use the hole in the opposite end of the template to layout the installation hole. The result will be a 14" circle. (Figure 9)



Figure 9

Step 2. Cutting the Installation Hole

- Drill a hole inside the circle large enough to insert the blade of a reciprocating saw. Use the reciprocating saw to follow the circle pattern for the installation hole. (Figures 10 and 11)

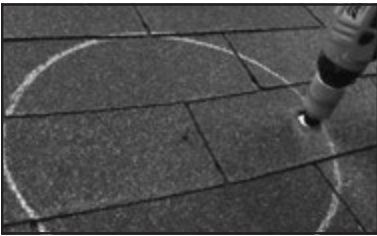

Figure 10



Figure 11

Note: Be careful not to cut through any rafters or framing members.

Before completing the entire cut, take necessary precautions to ensure the area being cut does not fall into the attic.

Step 3. Temporarily Remove Shingles above Installation Hole

- Carefully remove the shingles above the hole starting at a location as close to the mid-point of the hole as possible. (Figure 12)

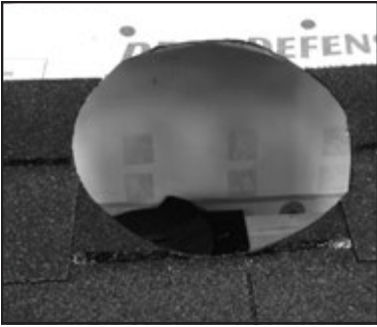

Figure 12

Note: The removed shingles will be re-installed later.

Step 4. Final Positioning

- Apply a generous amount of asphalt roofing cement to the bottom of the solar fan flashing (Figure 13). We recommend using a roofing cement meeting ASTM D4586, Type I.



Figure 13

- Position the solar fan directly over the hole using the “UP” label as a guide for orientation.
- Before securing the solar fan to the deck make sure the fan is centered over the 14" hole. (Figures 14 and 15)



Figure 14



Figure 15

- Secure the solar fan to the roof deck using all 8 installation holes and the steel screws provided. (Figure 16)

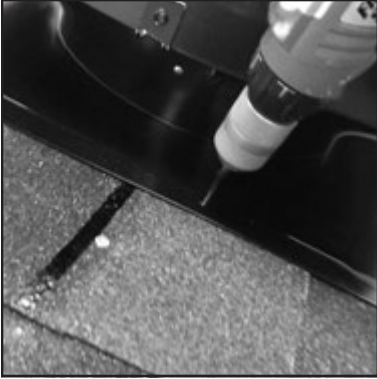

Figure 16

- Apply roofing cement to the screw heads. (Figure 17)



Figure 17

Step 5. Re-install Shingles Removed Earlier

- Re-install the removed shingles over the solar fan's flashing starting at the fan and working up. (Figure 18)



Figure 18

- Use roofing cement to seal the nail heads and any open holes from old nails.
- Hand seal the replaced shingles with roofing cement.

Reminder: Use an appropriate amount of roofing cement, as an excessive amount can cause shingles to blister.

Step 6. Adjusting the Angle of the Solar Panel

- The optimal adjustment is to have the solar panel face the sun at a 90° angle at the midday path of the sun. The panel can be re-adjusted during winter or summer seasons if desired.
- To adjust the tilt of the panel remove the screws (Figure 19) on both sides of the panel assembly and set aside.

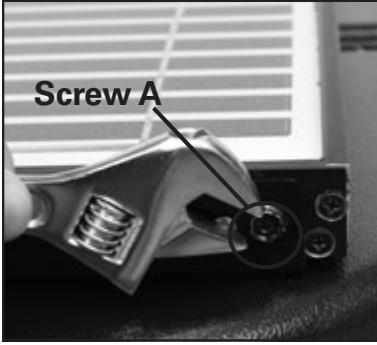

Figure 19

- Lift the panel and swing the panel braces up to the desired position and re-attach the screws at the new location (Figure 20). Note: there are 3 positions to choose from, including parallel to the panel's tray.



Figure 20

Note: The solar panel is most effective when clean and free of dust, leaves, and debris. Normally rainwater will cleanse the solar panel but if necessary hose off the panel between rain showers. Do not use any abrasive cleaners on the panel, this can scratch and dull the surface.

Step 7. Adjusting the Rotation of the Solar Panel on the Tray

- To rotate the panel, loosen the 4 nuts marked “B”. (Figure 21)

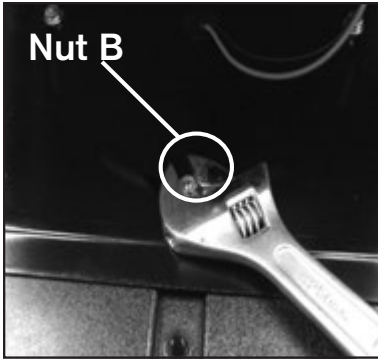

Figure 21

- Rotate the panel base to the desired location and re-tighten the nuts. The panel base can be rotated up to 360° by removing nuts “B”, lifting the assembly off the bolts and re-positioning accordingly. (Figure 22)

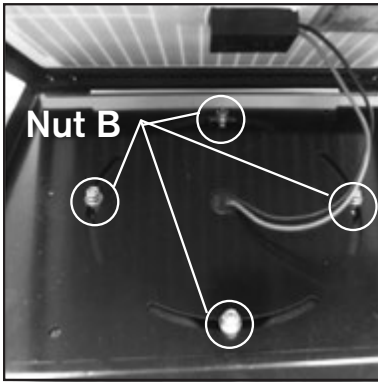

Figure 22

- Re-attach the nuts and tighten when completed.

Optional Installation Location for the Solar Panel

If desired, the solar panel can be separated from the fan's base and installed in a remote location on the roof. This is sometimes preferred to maximize the sunlight captured throughout the day. Please adhere to the following instructions when installing the solar panel remotely from the *VentSure* Solar Attic Exhaust Fan—Roof Mount Unit.

Important: For installing the solar panel remotely from the fan's base, 30-Foot Extension Wire needs to be purchased separately from your building materials supplier. Please ensure you use the extension wire specific to the *VentSure* Solar Attic Exhaust Fan

While we recommend keeping the distance within 30 feet, the panel can be placed up to 60 feet away from the fan's base without a meaningful drop in performance.

Note: Distances between 30 and 60 feet will require (2) 30-Foot Extension Wires.

Remove the Solar Panel assembly

Step 1

Remove the 2 tilt support screws and lift the solar panel to gain access to the junction box and the solar panel assembly mounting nuts. (Figures 23 and 24)

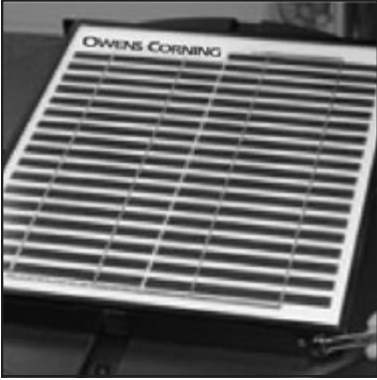

Figure 23

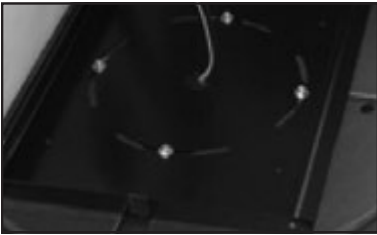

Figure 24

Step 2

Remove the junction box cover and remove the 4 screws holding the wires and the strain relief bracket. (Figure 25)



Figure 25

Step 3

Remove the 4 nuts that attach the solar panel assembly and separate the solar panel assembly from the fan. (Figure 26)



Figure 26

Step 4

Cut the remaining wires just above the wire-way nipple. DO NOT pull them out through the shroud or the watertight seal will be destroyed. (Figure 27)



Figure 27

Attaching the cable extension to the solar panel

Step 1

Slide the “eye” connector ends of the remote extension adapter through the hole in the junction box and replace the 4 screws. Make sure the red wire is on the positive (+) terminal typically on the right side of the box. (Figures 28 and 29)

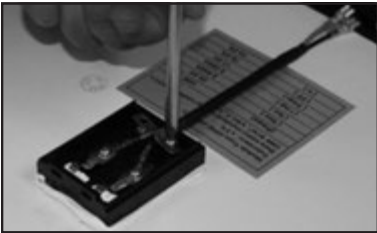

Figure 28

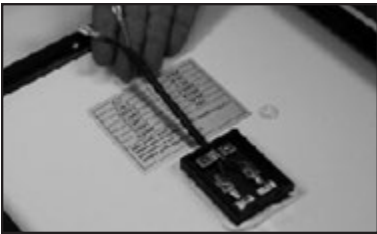

Figure 29

Attaching the wire extension kit to the fan

Step 1

Locate the quick connector under the fan shroud. Cut the zip ties and separate the quick-connector. (Figures 30 and 31)



Figure 30



Figure 31

Step 2

Connect the quick connectors between the wire extension kit and the cable coming from the motor. The other remaining cable will not be used, but can remain. (Figure 32)



Figure 32

Step 3

Tuck the wire connection up under the shroud and tie wrap securely into place. (Figure 33)



Figure 33

You are now ready to mount the solar panel remotely on the roof.

Remote Panel Mounting on Asphalt Roofs

Step 1

After determining a location for mounting the solar panel, go into the attic and make sure the location will allow a $\frac{3}{8}$ " diameter hole without hitting a rafter. Once the location has been confirmed drive a nail through the roof deck from the attic side. (Figure 34)



Figure 34

Locate the nail shank on the roof. This will be the center of the solar mount location.

Step 3

Mark the location and remove the nail. Drill a $\frac{3}{8}$ " diameter hole where the nail was removed.

Step 4

Locate the solar panel mounting base over the $\frac{3}{8}$ " diameter hole lining up the center hole in the mounting base with the $\frac{3}{8}$ " diameter hole in the roof deck.

Step 5

Loosen and remove screw A (both sides) to allow the panel to swing away from the base. Set the screws aside. (Figure 35)



Figure 35

Step 6

Pull the wire back through the hole in the center of the base to allow the base to lay flat on the roof deck. (Figure 36)



Figure 36

Step 7

Fasten the mounting base to the roof deck using the four (4) 3" galvanized screws. Seal the tops of the mounting screws with an exterior grade silicone sealant. Tilt the panel away from the base when installing the screws. If the panel is to remain flat against the base, it is recommended to allow the sealant to completely dry before it comes in contact with the panel. (Figures 37 and 38)



Figure 37



Figure 38

Step 8

After attaching the mounting base to the roof deck, feed the connecting cable through the hole in the roof deck. Leave enough slack under the solar panel to allow the panel full travel to avoid pinching the cable or pulling on the cable connection during adjustment.

Step 9

Adjust the tilt of the panel to maximize exposure to the sun throughout the day. The optimal adjustment is to have the panel 90 degrees to mid-day path of the sun. If desired, the angle of the panel can be adjusted as the seasons change to maximize sunlight captured.

Step 10

After the panel is adjusted to the desired position, secure the cable to one of the support arms using a tie wrap.

Step 11

After the cable is secured, seal the area around the cable where it enters the roof deck with exterior grade silicone sealant to keep water from entering the attic around the cable.

Step 12

Locate the cable in the attic and drape the cable from rafter to rafter and connect to the cable from the fan. Secure any excess cable to the rafters with tie wires or coaxial staples.

Remote Panel Mounting for Tile or Metal Roofs

Step 1

Determine the location of the contact points by positioning the panel in the desired area. For Spanish tile roofs, find a position with as much surface area coming in contact with the bottom of the panel as possible. The panel must be mounted on at least 2 rows of tile as shown. (Figures 39 and 40)



Figure 39



Figure 40

Step 2

Apply enough roof tile adhesive to the underside of the base to firmly secure the panel to the surface. Both surfaces should be dry and free of any dirt or solvents. (Figure 41)

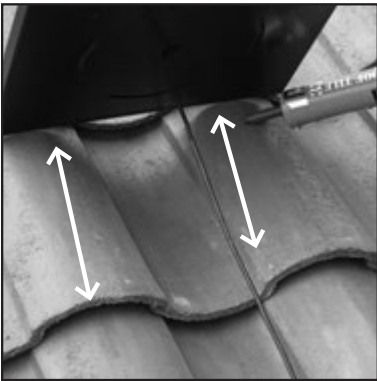

Figure 41

Step 3

The panel can be tilted into 2 positions with the adjustment arm, choose the best angle and reinstall the adjusting screws (screw A). (Figure 42)



Figure 42

Installing an Additional Solar Panel (Optional)

Depending on the location of the primary solar panel, you may wish to add an additional solar panel to increase the amount of time the fan is powered by solar energy throughout the day.

For these situations, consider the *VentSure Additional Solar Panel Kit*, available through your building materials supplier.

VentSure® Solar Attic Exhaust Fan Controller Module

Installation Guide for the Controller Module with Built-in Thermostat and Humidistat

The Controller Module consists of:

- Attic-mounted Controller Module with built-in Humidistat and Thermostat
- AC Adapter (required for electric backup, if desired)
- 8-foot cable
- Remote Access Monitoring Device and Holster (optional)



Pre-Install Check

Please read the instructions before proceeding with installation. If your Solar Attic Fan has already been installed, make sure the Solar Fan is working properly before installing the Controller Module components.

Note: The Controller Module can be installed with or without house electricity.

Standard Installation—Functionality

When performing the standard installation (without hooking up to house electricity), the Controller Module will operate only on power generated by the solar panel and will provide these functions:

1. Read attic temperature and relative humidity and display them on the Controller Module.
2. Humidistat—Turns the fan on, provided solar power is available, at or above 75% humidity, and off below 65% humidity.
3. Thermostat—Turns the fan on, providing solar power is available, at or above 80°F, and off at or below 77°F.

Note: These functions will be active only when the sun is available to generate electricity from the solar panel

Installation with Use of House Electricity—Functionality

Installing the Controller Module with the AC Power Adapter will provide these additional benefits:

1. Extends fan operation into the evening hours
2. Allows fan to operate when inadequate sunlight is available
3. Intelligently limits the amount of house electricity to be used for adequate ventilation

Standard Installation Steps

Step 1

Bring all Controller Module components to the attic.

Step 2

For best results, locate the Controller Module near the fan opening (Figure 1).



Figure 1

Mounting within 2 to 3 feet of the motor on a nearby rafter close to the underside of the roof is recommended. (Figure 2)



Figure 2

Note: The Controller Module has vents on either side of the housing that allow the temperature and humidity sensors to work, so it is important to locate the Controller Module with at least 1" of space between it and the underside of the roof.

Step 3

Use the quick connect leads coming from the motor to connect to the quick connect leads of the Controller Module.

Step 4

From underneath the fan, disconnect the "Quick-Connect" near the motor.

Step 5

Using the cable provided, connect one wire to the leads coming from the motor and connect the other end to the leads marked "Fan" on the Controller Module.

Step 6

Connect the remaining lead coming from the solar panel to the cable provided and connect the other end to the lead marked "Solar" on the Controller Module.

Warning: Fan will begin running as soon as the sun hits the solar panel—keep everything clear of fan blades.

Step 7

The cable connectors have been designed to prevent incorrect connections. Confirm the leads going to the motor connect to the leads labeled "Fan" on the Controller Module, and the leads going to the solar panel connect to the leads labeled "Solar" on the Controller Module. (Figure 3)



Figure 3

Step 8

Provided there is sunlight to the solar panel, the LCD display is now activated and will read the current attic temperature and relative humidity. When the Controller Module logic detects the fan in operation, the fan and solar LEDs will light up accordingly on the Controller Module. This will take approximately 30 seconds.

Step 9

Use the included tie wraps and 1/4" or 1/2" coaxial staples, available from your local hardware store or builders' supply, to secure the wiring harness to the rafter. (Figures 4 and 5)



Figure 4

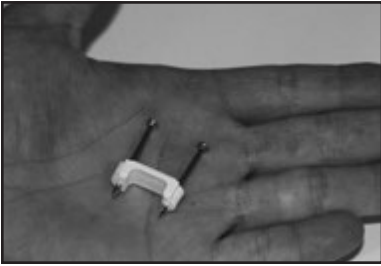

Figure 5

The Controller Module is now installed and running via power generated by the solar panel.

Installation with Use of Optional House Electricity

Be sure to follow all local building codes when installing the 110V outlet in the attic. Best practice would be to consult an electrical contractor.

To utilize the house electricity option connect the Controller Module to an AC outlet using the AC Power Adapter provided.

DO NOT USE AN EXTENSION CORD FOR THIS CONNECTION

Step 1

Complete steps 1-9 in the standard installation instructions.

Step 2

Temporarily disconnect wiring to the solar connectors at the Controller Module.

Step 3

The AC Power Adapter comes with 4.5 feet of cord. Make sure the 110V outlet is located within 4.5 feet. (DO NOT USE AN EXTENSION CORD) (Figure 6)



Figure 6

Step 4

Connect the AC Power Adapter to the port on the Controller Module as shown. (Figure 7)



Figure 7

Step 5

Plug the AC Power Adapter into the 110V power source (outlet). (Figure 8) The Controller Module will display attic temperature and relative humidity.



Figure 8

Step 6

1/4" or 1/2" coaxial staples can be used to secure the wire to the rafter (not provided). (Figure 9)



Figure 9

Step 7

Reconnect the wiring to the solar connectors at the Controller Module.

The Controller Module will now utilize the solar panel AND house electricity to optimize fan operation.

Power Source

1. Whenever available, solar power is the default power source. On a typical day with proper sunlight, the fan will operate until sunset.
2. If solar power is not available, the fan will not operate unless the Controller Module is installed with the AC Power Adapter connected to house electricity. The fan will continue operation in the following pre-set mode for 10 hours:
 - i. ON for 15 minutes and OFF for 15 minutes in a 30-minute period. This is the most effective air circulation frequency to keep the attic temperature close to the outside temperature.
 - ii. The fan will run for a maximum of 10 hours on intermittent house electricity.
 - iii. The fan will run on solar power whenever solar power becomes available again.
 - iv. After 10 hours of running on intermittent house electricity, the fan will be turned off for up to 8 hours, then turned back on, assuming solar power is not available during this period of time.



*Remote Attic Monitor
(Optional)*

Additional Accessory Available—Remote Attic Monitor

1. Provides convenient readout of fan status, attic temperature and attic humidity.
2. Remotely manages fan's operating logic by engaging or disengaging the thermal switch.
3. One remote can monitor up to 3 fans.

Power Source Summary		
Primary Power Source	Solar Fan with Controller Module WITHOUT AC Adapter connected	Solar Fan with Controller Module WITH AC Adapter connected
Daytime—with sufficient solar power	Solar power	Solar power
Evening after sunset	No power available	Intermittent house electricity for 10 hours

VentSure® Solar Attic Exhaust Fan Remote Attic Monitoring Device (Optional)

The Remote Attic Monitoring device allows the user to see the temperature and humidity conditions in their attic from nearly anywhere in the home. It also identifies whether the fan is on or off and whether it is running on solar or electric power.

Kit Includes:

- Remote Attic Monitor Holster
- Remote Attic Monitoring Device
- Two (2) AAA Batteries
- Two (2) Mounting Screws

Important Notes

The Remote Attic Monitoring device is designed to work with VentSure® Solar Attic Exhaust fans (gable and roof mount units) installed with the Controller Module. Do not attempt to use the Controller Module or Remote Attic Monitoring device with any other solar attic fans.

Please ensure your *VentSure* Solar Attic Exhaust Fan and Controller Module have been installed and are working properly prior to setting up the Remote Attic Monitoring device.



Setting the Remote Attic Monitor After the Controller Module

Step 1

The Attic-mounted Controller Module has 2 slide switches: the one on the left is for selecting the Radio Frequency (RF) channel and the one on the right is for selecting the temperature readout in Celsius (°C) or Fahrenheit (°F). Select the same RF channel (choice of 1, 2, or 3) on the Remote Attic Monitor and on the Controller Module. Both must be on the same channel in order to send and receive signals. Also, ensure the desired temperature readout is selected on the Controller Module.

Step 2

Remove the back panel of the Remote Attic Monitor. Insert 2 AAA batteries (included) in the battery compartment. Replace the back panel of the battery compartment.

Step 3

Test the Remote Attic Monitor by pressing the Status button once. This will establish the connection between the Controller Module and Remote Attic Monitor. You will hear a “beep” every time the Status button is pressed. This verifies the Remote Attic Monitor and Controller Module RF signals are aligned. If there is not a beep, check that the RF channel selector is set to the same channel. If there still isn't a beep, move both devices to an alternative channel and retry.

Using the Remote Attic Monitoring Device

The Remote Attic Monitor has one status button on the front below the LCD display, and a Thermo Switch selector on the back.

Front of the Remote Attic Monitor

Channel Setting

There are 3 available RF channels. Ensure the same RF channel is selected on the Controller Module and Remote Attic Monitor. The RF channel ID must match in order to transmit information.

Status Button

When the Status button is pressed, a beep will sound from the Controller Module to signify a proper connection between the Controller Module and Remote Attic Monitor. The Remote Attic Monitor's LCD display will show the following information:

- Attic Temperature
- Attic Relative Humidity
- Fan Mode—ON, OFF, Intermittent, or Failure
- House Power—ON
- Solar Power—ON

The status will be displayed for approximately 20 seconds. Press the Status button again to refresh the information after 20 seconds. If the beep doesn't sound after pressing the Status button, no connection has been made with the Controller Module and the LCD display will go blank.

Check the following if there is no display on the Remote Attic Monitor after pressing the Status button:

- Batteries have been installed; Replace if necessary
- RF channel is properly aligned between the Controller Module and Remote Attic Monitor
- Controller Module wire connections are correct
- AC Power adapter is connected to the Controller Module for after dark operation
- If the problem persists, contact us at 1-800-GET-PINK®.

Back of the Remote Attic Monitor

Thermo Switch selector—ON or OFF

The Thermo Switch allows the user to engage or disengage the temperature control.

When the Thermo Switch is set to:

- ON mode—Fan will only operate when the attic temperature reaches 80°F and power is available. Once running, the fan will shut off when the temperature drops below 77°F.
- OFF mode—Fan will operate whenever a source of power is available, regardless of attic temperature

Note: The only exception is if solar power has not been generated for 8 hours AND the Controller Module is installed with the AC Power Adapter connected to house electricity. In this instance, the fan will operate for 10 hours, then shut off for 8 hours or until solar power is generated. During each of the 10 hours the fan is operating via electric backup, the fan will operate for 15 minutes and then shut off for 15 minutes.

After making a change to the Thermo Switch on the Remote Attic Monitor:

- Click the Status button and send the command to the Controller Module.
- Wait 5 seconds for the Controller Module to change the fan operation.
- Click the Status button again to read the current fan operation status.

Humidity Control—Always Enabled

The relative humidity sensor is always enabled (the user cannot disable the sensor). The fan will be turned on when attic relative humidity reaches 75%, regardless of attic temperature. The fan will turn off when relative attic humidity drops to 65%.

Source of Power

1. Whenever available, solar power is the default power source. On a typical day with proper sunlight, the fan will operate until sunset.
2. If solar power is not available, the fan will not operate unless the Controller Module is installed with the AC power adapter connected to house electricity. The fan will then continue to operate in the following pre-set mode for 10 hours:
 - i. ON for 15 minutes and OFF for 15 minutes in a 30-minute period. This is an efficient cycle for trying to keep the attic temperature close to the outside temperature.
 - ii. The cycle will run for a maximum of 10 hours on intermittent house electricity.
 - iii. The fan will run on solar power whenever solar power becomes available again.
 - iv. After 10 hours of running on intermittent house electricity, the fan will be turned off for up to 8 hours, then turned back on, assuming solar power is not available during this period of time.

Power Source Summary		
Primary Power Source	Solar Fan with Controller Module WITHOUT AC Adapter connected	Solar Fan with Controller Module WITH AC Adapter connected
Daytime—with sufficient solar power	Solar power	Solar power
Evening after sunset	No power available	Intermittent house electricity for 10 hours
<p><i>Note: The primary power source is always SOLAR. If solar power is not available during the daytime, the primary power source will switch to house electricity (if the Controller Module is connected to house electricity) for up to 10 hours or until solar power becomes available.</i></p>		

Refer to the LCD Display Summary to interpret the LCD display and the fan's operating status.

Multiple Fan Setup—3 or Less Fans







Assign 1 of the 3 available channels to each of the Controller Modules. A beep will come from the Controller Module that is communicating with the Remote Attic Monitor. The user can use the same Remote Attic Monitor to control all 3 fans by selecting the correct RF channel. Do not assign the same RF channel to 2 or more Controller Modules.

4 or more fans—Consult 1-800-GET-PINK®

Additional Information

Please visit our website www.owenscorning.com/roofing for additional product information and FAQs. You can also call 1-800-GET-PINK® and one of our Customer Service Representatives will be able to help you.

LCD Display Summary

LCD Display	House Power	Solar Power	Fan	Operation Summary
	(blank)	ON	ON	<ul style="list-style-type: none"> Solar power is available Fan is running
	(blank)	ON	OFF	<ul style="list-style-type: none"> Solar power is available Fan is not running Attic temperature is < 80°F Thermo Switch could be ON To run fan, switch Thermo Switch to OFF, then press the Status button twice
	ON	(blank)	ON-Intermittent	<ul style="list-style-type: none"> Solar power is not available Fan is powered by house electricity Fan is running intermittently, currently in the 15-minute ON mode of the 10-hour cycle
	ON	(blank)	Intermittent	<ul style="list-style-type: none"> Solar power is not available Fan is powered by house electricity Fan is running intermittently, currently in the 15-minute OFF mode of the 10-hour cycle
	ON	(blank)	OFF	<ul style="list-style-type: none"> Solar power is not available Fan is powered by house electricity Fan is in the 8-hour OFF mode Fan will restart when solar power becomes available, or at the end of the 8-hour OFF mode
	(blank)	ON	Failure	<ul style="list-style-type: none"> House electricity is available Fan is not running Possible problems: <ul style="list-style-type: none"> Loose wiring Motor failure Controller Module failure
	ON	(blank)	Failure	<ul style="list-style-type: none"> Solar power is available Fan is not running Possible problems: <ul style="list-style-type: none"> Loose wiring Motor failure Controller Module failure

VentSure® Solar Attic Exhaust Fan Gable Mount Unit

This fan can be used for installations where roof mounting is impractical or not preferred. The fan can be installed in a gable, crawlspace, or under an existing off-ridge vent to provide increased performance for off-ridge vents. While the fan is installed inside the attic, the solar panel will be remotely mounted on the exterior of the home to capture and utilize energy from the sun.

Before installing this product, check local building codes for their roofing requirements.

The manufacturer will not be responsible for problems resulting from any deviation from the recommended application instructions.

Box Contents—Unpack and Check.

You should have:

- (A) Fan assembly
- (B) Solar panel with 30 ft. of attached wire
- (C) Wall mounting brackets (2 ea.)
- (D) Attic Mounted Controller Module
- (E) 4 - Mounting Screws
- (F) 2 - 8' Cables
- (G) AC Power Adapter

Mounting bracket bolt and nut (4 ea.)
1.5" screws for fan mounting (8 ea.)

TOOLS REQUIRED

- Power drill with phillips head driver and an 1/8" drill bit
- Adjustable wrench
- Measuring tape
- Tin snips or wire cutters (for cutting hole in vent screen)
- Circular saw or handsaw (for cutting 2x4s for bracing if req.)
- Pencil or marking pen
- 1/4" coaxial staples (for securing the wire after installation)
- Caulk gun with roofing sealant. We recommend ASTM D4586 Type 1 Asphalt Roofing Cement.



Optional Hardware (not included)

For fan mounting options:

- 3" galvanized deck screws (for mounting 2x4 braces to framing members if req.)

For panel mounting on rooftop:

- 2" pan head tapping screws (for mounting to composition roof)
- Caulk gun with roofing adhesive (for mounting solar panel directly to Spanish tile, flat tile or metal roofs)

For panel mounting on exterior wall:

- 1.5"-3" anchor screws (depending on your specific type of stucco, cement or brick wall. Must support up to 20 lb.)
- 1.5"-3" galvanized screws (depending on your specific type of wood or vinyl siding. Must support up to 20 lb.)
- Caulk gun with roofing sealant (for sealing screw heads when mounting to wood or vinyl siding)

Precautionary Notes

Positioning

- The solar panel should be positioned to face south or southwest for optimum performance and should be positioned where it is not shaded or blocked from the sun for extended periods throughout the day.

Ventilation Requirements

- Ventilation must meet or exceed Federal Housing Administration minimum property standard.
- Before beginning the installation, calculate the square feet of attic space being ventilated and select the recommended number of VentSure Solar Attic Exhaust Fans necessary for moving the required CFM (cubic feet per minute). Depending on the size of attic space to be ventilated, more than 1 solar fan may be required. See Fan Sizing Chart below.
- It is critical to ensure there is proper intake ventilation at the eave or fascia. For each Gable Mount fan, Owens Corning requires 890 square inches of intake. This is based on a ratio of 1 square foot of intake ventilation for every 150 square feet of attic space being ventilated.

Note: If it isn't practical to achieve the required amount of intake ventilation, Owens Corning recommends adequately sealing the attic floor and any HVAC ducts in the attic to prevent pulling air from conditioned space.

- Some attics have more than one walled off or chambered area. This situation will require fans for each area.
- To maximize the solar fan's effectiveness you should remove or block any rooftop static vents or ridge vents. This can be accomplished using any roofing underlayment, ensuring it is securely attached.

Fan Sizing Chart

Attic Size (Sq. Ft.)	Number of Gable Mount Fans Required		
	Low Slope 3:12–4:12	Medium Slope 5:12–8:12	Steep Slope 9:12–12:12
1,200	1	1	1
1,600	1	1	1
2,000	1	1	1
2,400	1	1	2
2,800	1	2	2

Determine your mounting application

One of the great features about the *VentSure* Solar Attic Exhaust Fan (Gable Mount) is the many mounting options.

Gable Vent

If you have a gable and prefer to avoid cutting into your roofing materials, use the gable vent for mounting the fan.



Gable Vent

Static or Turbine Vent

Rather than removing the static or turbine vent, simply use the same opening.



Static/Turbine Vents

Crawlspace Vent

If your crawlspace has too much moisture, increase the airflow and reduce moisture by installing near a vent opening.

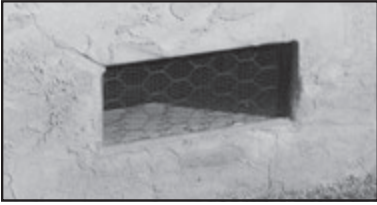

Crawlspace Vent

Before You Begin

Loosen (but do not remove) the 8 nuts (Figure 1) on the 4 mounting brackets (Figure 2) so they can slide freely. And remember: Always note the orientation of the fan's air flow relative to the vent opening.

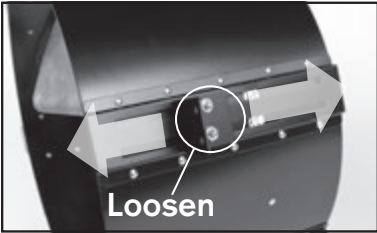

Figure 1

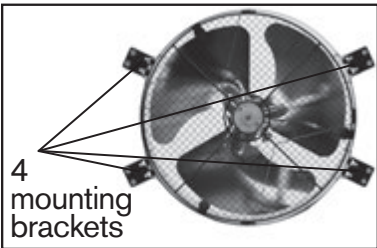

Figure 2

Gable Vent Installation

Important tip for both gable fan installation methods: To maximize efficiency of the fan, seal off the gable vent area around the fan to avoid recirculating outside air around the fan and back outside.

For installation in a gable vent you typically have two options:

Option 1

Vent is located between standard 16" on center framing

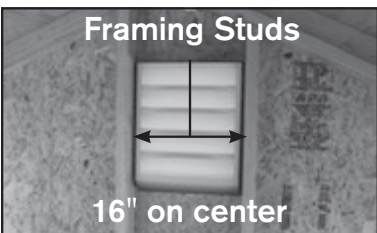

Option 1

Step 1

Position the fan over the louvers and slide the mounting brackets into position against the framing studs. (Figure 3)

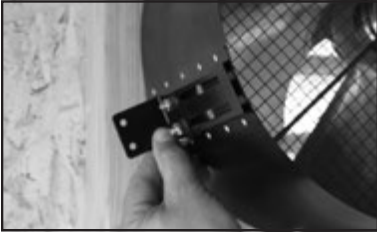

Figure 3

Step 2

Mark the position of the holes in the brackets and pre-drill if necessary. (Figure 4)



Figure 4

Step 3

Use included mounting screws to fasten the brackets to the framing studs. There are 8 attachment locations, with two on each bracket. (Figure 5)



Figure 5

Step 4

Once brackets have been fastened, slide the fan assembly into position, pressing it firmly against the vent louvers and tighten the 8 nuts. (Figure 6)



Figure 6

Option 2

Vent area requires additional mounting braces to support the fan

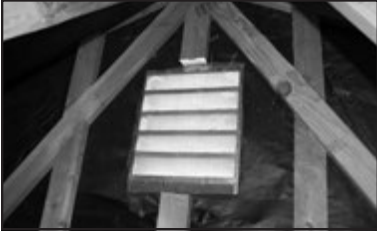

Option 2

Step 1

Measure the distance between the 2 framing members that the braces will attach to. (Figure 7)

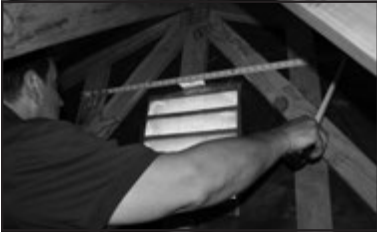

Figure 7

Step 2

Cut two 2x4 braces to the required length. (Figure 8)



Figure 8

Step 3

Locate the two braces between 14.25" and 15" apart and centered over the vent opening and then fasten to the framing members with 3" screws (not supplied). (Figure 9)



Figure 9

Step 4

Then mount the fan as described in Option 1. (Figure 10)

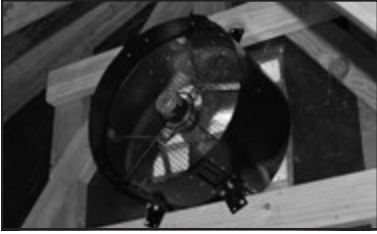

Figure 10

Static or Turbine Vent Installation

The Gable Mount unit can be used to push hot air out of your attic through an existing roof vent.



Static or Turbine Vent

Important Tip: Seal off other static vents to avoid turning them into intake vents once the powered fan is installed and running.

Step 1

Determine the location of the vent to be used and measure the distance between the two rafters. (Figure 11)

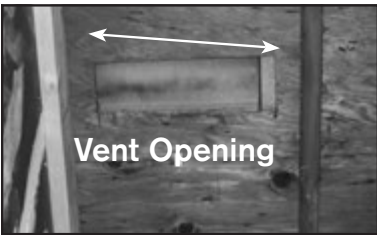

Figure 11

Step 2

Cut two 2x4 braces to the required length.

Step 3

Locate the two braces between 14.25" and 15" apart and centered over the vent opening then fasten to the rafters with 3" galvanized deck screws (not supplied). (Figure 12)

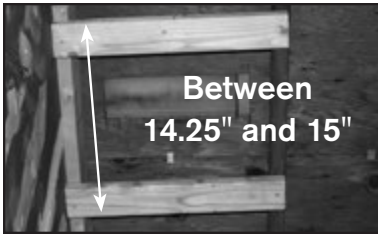

Figure 12

Step 4

Position the fan assembly between the two braces and slide the fan assembly towards the vent opening. (Figure 13)



Figure 13

Step 5

Fasten the brackets to the two braces with included mounting screws (Figure 13) and tighten the 8 nuts. (Figure 14)



Figure 14

Note: When the rafter is larger than a 2" x 4", (e.g. 2"x6") locate the braces between the rafters to ensure fan can be positioned against the vent.

Crawl Space Vent Installation

Keeping air moving in your crawl space can help to remove moisture and inhibit mold and mildew growth. The Gable Mount unit can be mounted as described above, or a box frame can be built to hold the fan in position. It is recommended that you evaluate your crawlspace to determine the best method.

To Build the Box Frame

Step 1

Depending on the distance your floor joists are separated, you will need to cut 4 braces: two at 14.5" for the side braces, one at 17.5" for the bottom brace and one between 17.5" and 25.5" for the top brace (Figure 15). Most floor joists are either 16" on center or 24" on center. Measure the distance before cutting the top brace to be sure of the distance required.



Figure 15

Step 2

Fasten the 4 boards together with 3" screws to make a square box with inner dimensions 14.5" x 14.5". (Figures 16 and 17)



Figure 16

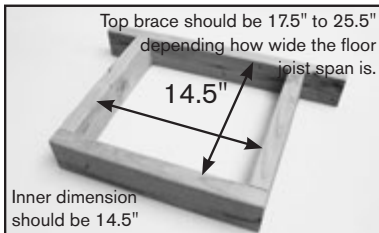

Figure 17

To mount in crawlspace

Step 3

Mount the frame in front of the vent opening by attaching it to the floor joists with 3" galvanized screws. If the frame assembly and fan mount lower than the bottom of the vent opening, (Figure 18) mount the frame about 8" to 10" away from the vent to prevent direct contact with the foundation when the fan is mounted. (Figure 19) Secure the frame to the bottom of the floor joists with at least 2 screws on each side making sure it is centered evenly on both. (Figure 20)

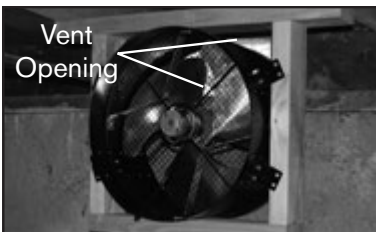

Figure 18

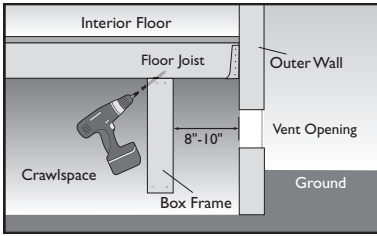

Figure 19

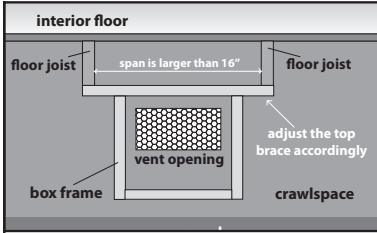

Figure 20

Step 4

Mount the fan inside the frame by attaching the brackets with included mounting screws. Center the fan in the frame making sure that there is at least 4" of clearance between the fan housing and the crawlspace vent opening. (Figure 21)

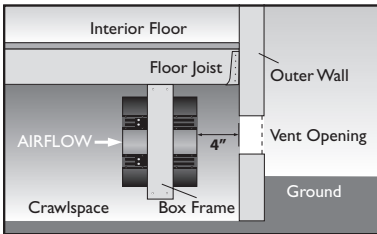

Figure 21

Mounting the Solar Panel

Maintenance Tip: The solar panel is most effective when clean and free of dust, leaves, and debris. Normally, rainwater will cleanse the solar panel and keep it operating at peak efficiency. If necessary, simply hose off the solar panel between rain showers.

Surface mounting on asphalt roofs:

Step 1

Determine the desired location for mounting the solar panel. It is recommended the panel be placed within 30 feet from where the fan will be installed. Identify a location that will maximize exposure to the sun's path throughout the day. South or Southwest facing roof slopes are ideal.

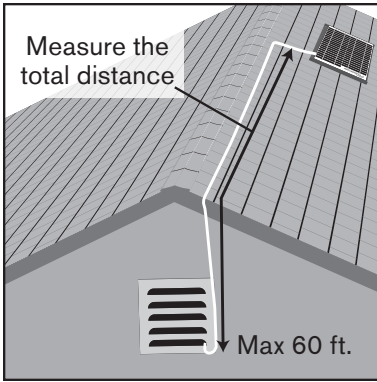

Figure 22

Note: This product comes with 30 feet of extension wire, as this is suitable for the vast majority of installations. However, the panel can be placed up to 60 feet away from the fan's location without having a meaningful drop in performance. If the distance exceeds 30 feet, a Wire Extension Kit specific to this product will need to be purchased separately from your building materials supplier.

Step 2

After determining a location for mounting the solar panel, go into the attic and make sure the location will allow a $\frac{3}{8}$ " diameter hole without hitting a rafter. Once the location has been confirmed drive a nail through the roof deck from the attic side.

Step 3

Locate the nail shank on the roof. This will be the center of the solar mount location.

Step 4

Mark the location and remove the nail. Drill a $\frac{3}{8}$ " diameter hole where the nail was removed.

Step 5

Locate the solar panel mounting base over the $\frac{3}{8}$ " diameter hole lining up the center hole in the mounting base with the $\frac{3}{8}$ " diameter hole in the roof deck.

Step 6

Loosen and remove screw A (both sides) to allow the panel to swing away from the base. Set the screws aside. (Figure 23)

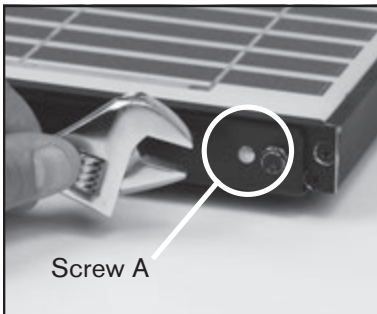

Figure 23

Step 7

Pull the wire back through the hole in the center of the base to allow the base to lay flat on the roof deck.

Step 8

Fasten the mounting base to the roof deck using the four (4) 3" galvanized screws. Seal the tops of the mounting screws with an exterior grade silicone sealant.



Figure 24

Tilt the panel away from the base when installing the screws. If the panel is to remain flat against the base, it is recommended to allow the sealant to completely dry before it comes in contact with the panel. (Figures 25 and 26)

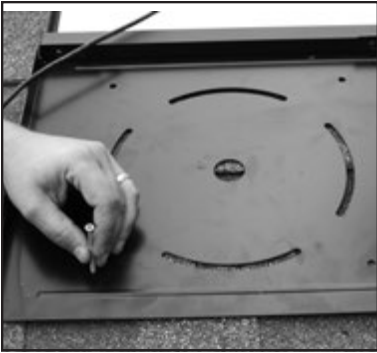

Figure 25

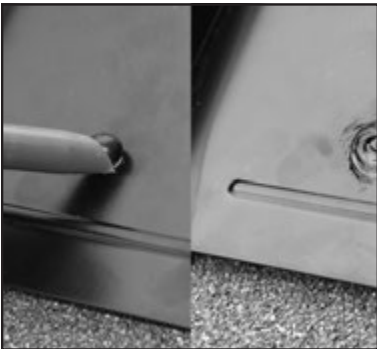

Figure 26

Step 9

After attaching the mounting base to the roof deck feed the connecting cable through the hole in the roof deck. Leave enough slack under the solar panel to allow the panel full travel to avoid pinching the cable or pulling on the cable connection during adjustment.

Step 10

Adjust the tilt of the panel to maximize exposure to the sun throughout the day. The optimal adjustment is to have the panel 90 degrees to mid-day path of the sun. If desired, the angle of the panel can be adjusted as the seasons change to maximize sunlight captured.

Step 11

After the panel is adjusted to the desired position, secure the cable to one of the support arms using a tie wrap.

Step 12

After the cable is secured seal the area around the cable where it enters the roof deck with exterior grade silicone sealant to keep water from entering the attic around the cable.

Step 13

Locate the cable in the attic and drape the cable from rafter to rafter and connect to the Gable Mount fan. Secure any excess cable to the rafters with tie wires or coaxial staples.

Surface Mounting for Tile or Metal Roofs

Step 1

Determine the location of the contact points by positioning the panel in the desired area. For Spanish tile roofs, find a position with as much surface area coming in contact with the bottom of the panel as possible. The panel must be mounted on at least 2 rows of tile as shown. (Figures 27 and 28)



Figure 27



Figure 28

Step 2

Apply enough roof tile adhesive to the underside of the base to firmly secure the panel to the surface. Both surfaces should be dry and free of any dirt or solvents. (Figure 29)

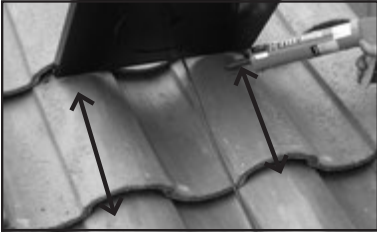

Figure 29

Step 3

The panel can be tilted into 2 positions with the adjustment arm, choose the best angle and reinstall the adjusting screws (screw A). (Figure 30)



Figure 30

Wall Mounting (Optional)

Brackets are included to mount the panel to a wall if preferred. (Figures 31 and 32)



Figure 31



Figure 32

Step 1

Attach the brackets to the panel using the 4 bolts (F) (Figure 33)

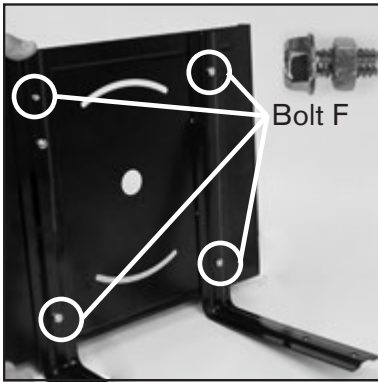

Figure 33

Step 2

Depending on the material your wall is made of, mount the assembly to the wall using appropriate fasteners (see “Optional Hardware” for details). (Figure 34)

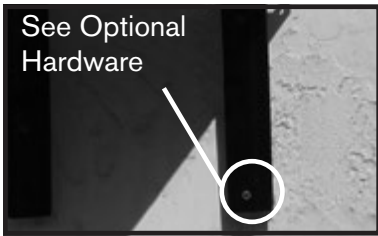

Figure 34

Fascia Mounting (Optional)

The Fascia Mounting Kit allows you to install the solar panel of the VentSure™ Solar Attic Exhaust Fan—Gable Mount and Additional Solar Panel Kit directly to a fascia board. This gives you another option for mounting the panel instead of on the roof tiles or an exterior wall.

Attach the fascia brackets to the fully assembled wall brackets included with your VentSure™ Solar Attic Exhaust Fan—Gable Mount Unit



Optional Fascia Mounting Kit
and Brackets

Step 1

On a flat surface, orient the fascia and wall brackets as shown. (Figure 35) You can also install on wall brackets that are already attached to the panel—just make sure they are facing the same direction.



Figure 35

Step 2

Locate the lower hole on the wall bracket (Figure 36) and fit the bolt through the 2 brackets and attach the nut. (Figure 37)



Figure 36



Figure 37

Step 3

Repeat Step 2 for the upper hole with another bolt and nut. (Figure 38 and 39) Once both nuts are secure, tighten completely with an adjustable wrench.



Figure 38



Figure 39

Step 4

Repeat all the steps again for the second bracket. Then attach to the solar panel as illustrated in Figure 33.

Attach the complete assembly to your fascia board

Step 5

Find a desired location for the completed assembly and attach with (4) 1.5" galvanized screws (not included) or fasteners appropriate for your fascia material. (Figure 40 and 41). Once secure, adjust the panel as desired.

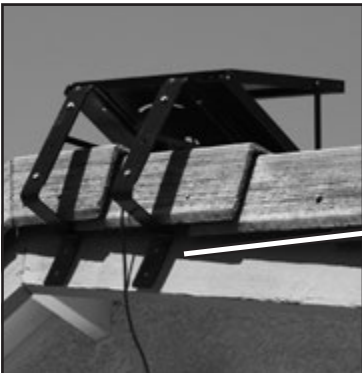

Figure 40

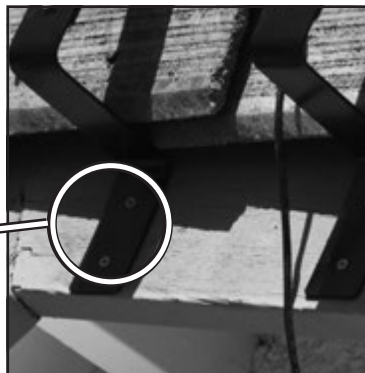

Figure 41

Preventing Damage from Ice Dams

Snow and ice formations on roofing structures can create ice dams at the roof eaves. Ice dams are typically formed by the continual thawing and freezing of melting snow or backing up of frozen slush in gutters. When ice dams occur, water can be forced under the roof and may cause damage to a home's ceilings, walls and insulation, and long-term damage to structural components.

The installation of eave flashing is the recommended method for preventing leakage from ice dams. In climates where icing along the eave is anticipated (where the average January temperature is 25°F or less), eave flashing must be installed to ensure maximum protection against ice dam damage. The appropriate selection of flashing material and the flashing strip width will depend on the roof slope and the severity of icing conditions anticipated.

1. New Construction

Low Slope Application:

On pitches 2 inches per foot to 4 inches per foot, cover the deck with a self-adhering waterproofing underlayment. These underlayments come in various widths and lengths. Begin by applying the self-adhering underlayment along the eave flush with the drip edge. All succeeding courses will be overlapped according to the manufacturer's instructions. In all applications the product should extend a minimum of 24 inches inside the interior wall line of the building.

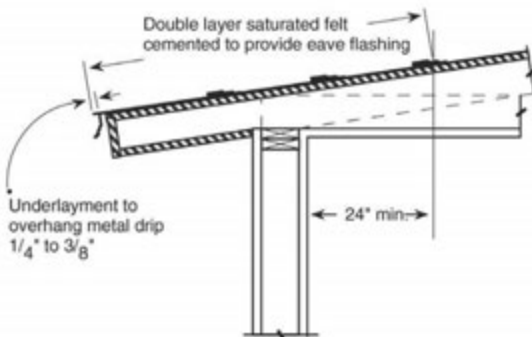

Figure A: Eaves flashing for low slope using asphalt saturated felt

As an alternative on pitches 2 inches per foot to 4 inches per foot, cover the deck with two layers of asphalt saturated felt. Begin by applying the felt in a 19 inches

wide strip along the eaves and overhanging the drip edge by $\frac{1}{4}$ to $\frac{3}{4}$ inches. Place a full 36 inches wide sheet over the 19 inches wide starter piece, completely overlapping it. All succeeding courses will be positioned to overlap the preceding course by 19 in. If winter temperatures average 25°F or less, thoroughly cement the felts to each other with plastic cement from eaves and rakes to a point of a least 24 inches inside the interior wall line of the building.

Normal Slope (4 inches per foot or greater):

In areas where ice builds up along the eave or a backup of water from frozen or clogged gutters is a potential problem, self-adhering underlayments (or any specialty eave flashing product) may be applied to eaves, rakes, ridges and valleys, and around chimneys, skylights or dormers to help prevent water damage. Start the first course at the eave, applying flush with the drip edge. Apply the self-adhering membrane to a point at least 24 inches inside the interior wall line.

If self-adhering membranes are not available, install a course of smooth, coated roll roofing, not less than 50 pounds, and parallel to the eave. This course should overhang both the underlayment and the metal drip edge by $\frac{1}{4}$ to $\frac{3}{4}$. Starting at the eave, apply the roll roof flashing strip to a point at least 24 inches beyond the interior wall line. If a second flashing strip is required to reach that point, locate the lap in front of the exterior wall line. Overlap the flashings at least 2 inches and cement the horizontal joint over its entire length. End laps should be 6 inches and cemented. See Figure B.

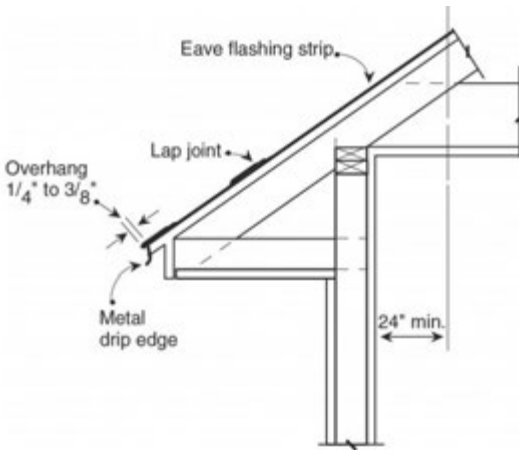

Figure B: Eaves flashing for normal slope using asphalt saturated felt

2. Reroofing and Repair

When repairing or reroofing over an existing roof, remove the old roofing to a point at least 24 inches beyond the interior wall line and follow the application instructions above for the appropriate roof slope.

DISCLAIMER OF LIABILITY: This document was prepared by the Asphalt Roofing Manufacturers Association and is disseminated for informational purposes only. Nothing contained herein is intended to revoke or change the requirements or specifications of the individual roofing material manufacturers or local, state and federal building officials that have jurisdiction in your area. Any question, or inquiry, as to the requirements or specifications of a manufacturer, should be directed to the roofing manufacturer concerned. **THE USER IS RESPONSIBLE FOR ASSURING COMPLIANCE WITH ALL APPLICABLE FOR ASSURING COMPLIANCE WITH ALL APPLICABLE LAWS AND REGULATIONS.** Nothing contained herein shall be interpreted as a warranty by ARMA, either express or implied, including but not limited to the implied warranties of merchantability, fitness for a particular purpose or non-infringement. **IN NO EVENT SHALL ARMA BE LIABLE FOR ANY DAMAGES WHATSOEVER,** including special, indirect, consequential or incidental damages or damages for loss of profits, revenue, use or data, whether claimed in contract, tort or otherwise. Where exclusion of implied warranties is not allowed, ARMA's liability shall be limited to the minimum scope and period permitted by law.

Technical Services Bulletin

Decorative Rake Trim as an Alternative to Drip Edge

Key consideration:

- Drip edge helps in preventing wind drive rain for entering the roofing system
- Drip edge is required for the Platinum warranty
- Drip edge may be required by local building codes

Owens Corning Roofing and Asphalt LLC Position:

Because of architectural designs of homes built in the last 20 years a variety of decorative style of rake edging is being used. These edging are primarily vinyl, wood or metal and are designed for greater rake trim appeal. When trim edge of this style is used it is not practical to use a standard type drip edge metal without it affecting the architectural look of the home.

Owens Corning will allow as an exception the use of existing trim edge to be used as an alternative to drip edge metal.

Shown below are a few examples:

Metal

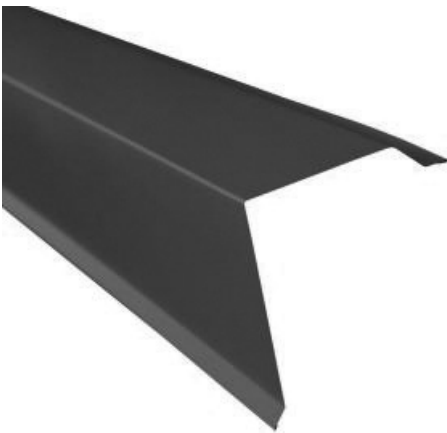

Wood



AFF-008-F

Technical Services Bulletin

Sidewall and Front Wall Flashing

Key consideration:

- Sidewall and Front wall flashing is required by building code
- New flashing is required for the Platinum warranty
- Properly installed flashing helps to direct water away from wall penetrations

Owens Corning Roofing and Asphalt LLC Position:

Because of certain types of architectural designs of homes we understand that different style of siding can be used. An example of these are vinyl, aluminum, wood, stucco, brick and cementitious type board.

When reroofing a home with the above example siding it may become difficult to replace existing flashing without damaging the siding. This sometimes create a challenge for the roofing contractor on what is the best solution for replacing/removing old flashing.

Position

Owens Corning will allow using existing flashing under the following conditions.

- The existing flashing should be in like-new condition
- It must be of the proper gauge required by local building codes
- It must be installed per the manufactures and building codes requirements

Do not use existing flashing that is.

1. Buckled
2. Rusted
3. Bent
4. Cracked
5. Broken

If you have any questions prior to re-using any existing flashing contact Owens Corning Roofing and Asphalt.

Owens Corning Resources



Design EyeQ® Online Visualization Software

Shingle color selection for some homeowners is a daunting task. Design EyeQ® is the visualization software Owens Corning runs on owenscorning.com/roofing to help homeowners "try on" a new roof before making a purchase. It gives you the opportunity to up-sell to a different shingle or potentially close the sale quicker if you can assist the homeowner in making that decision.



Roofing Color Compass® Quiz

HELPING YOUR CUSTOMERS HAVE FUN WITH DISCOVERING THEIR COLOR PERSONALITY

As a fun, good ice-breaker while you're measuring the roof, or as a means to help a homeowner make a shingle color choice, Owens Corning has developed a tool for you. The Roofing Color Compass® Quiz, featuring Duration® Designer Colors Collection shingles, asks 10 fun questions, and based on the answers suggests a color personality for your customer. It will definitely be a conversation starter.

Visit www.owenscorning.com/roofing/basics/find-your-color to access the quiz.

YOUR BUSINESS. POWERED BY OWENS CORNING.®



ProConnect™ Resource Center

to help manage your business 24/7: www.ocproconnect.com

ProDesk® Contractor Service Center is a daily resource open Monday – Friday from 8 a.m. – 8 p.m. EST exclusively to Owens Corning Roofing Contractor Network members: 1-866-PRODESK (776-3375)

Warranty Inspection

Questions: 844-509-8173 or ocinspect@owenscorning.com



Total Protection Roofing System® Flipbook^ & App

AN INTERACTIVE WAY TO HELP HOMEOWNERS UNDERSTAND THE ROOFING SYSTEM

Grow your business by increasing homeowner knowledge

Flipbook

As a roofing professional, you know that a roof is more than just shingles. You probably also know that many homeowners have a hard time comprehending the parts that make up their roof. If you've struggled with explaining the roofing system to homeowners, the Total Protection Roofing System® Flipbook is for you. It brings the importance of a complete roofing system to life in a way that homeowners are sure to understand. The transparent pages showcase the features and benefits of the individual products, but also show how a combination of products work together and are essential for a high performance roof.

If interested, order your Roofing Essentials® Accessory Products Flipbook through your Area Sales Manager, or call ProDesk® Contractor Service Center at 1-866-PRODESK (776-3375) and reference pub #10019266.

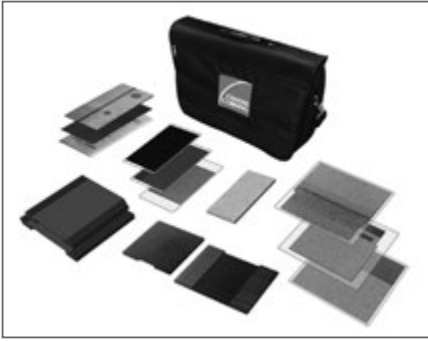

Roof-in-a-Bag

THE INNOVATIVE ADVANCED SELLING TOOL

Owens Corning Roof-in-a-Bag is an innovative selling tool that allows you to customize your system by selecting a sample of each accessory product you install based on region and preference.

This includes ventilation, ice and water barrier, underlayment, starter shingle, and hip and ridge product samples. It positions you as the subject matter expert as you demonstrate each component of the Owens Corning® Total Protection Roofing System® ^ during your in-home sales presentation.

Glossary of Terms

Algae Discoloration: A type of roof discoloration caused by algae. Commonly described incorrectly as fungus growth.

ASTM International: A voluntary organization concerned with development of consensus standards, testing procedures and specifications.

Asphalt: A bituminous waterproofing agent applied to roofing materials during manufacture.

Asphalt Primer: A thin liquid bitumen applied to a surface to improve the adhesion of self-adhering membranes and to absorb dust.

Asphalt Roof Cement: An asphalt-based cement used to bond roofing materials. Also known as flashing cement or mastic; should conform to ASTM D4586 (Asbestos Free).

Back Surfacing: Fine mineral matter applied to the back side of shingles to keep them from sticking together.

Base Flashing: That portion of the flashing attached to or resting on the deck to direct the flow of water onto the roof covering.

Base-ply sheet: A product intended to be the base or middle ply in a residential self-adhering roll roofing installation.

Base Sheet: A product intended to be used as a base ply in a self-adhering roll roofing installation.

Blisters: Bubbles that may appear on the surface of asphalt roofing after installation.

Brands: Airborne burning embers released from a fire.

Bridging: A method of reroofing with metric-size shingles.

Built-Up Roof: A flat or low-sloped roof consisting of multiple layers of asphalt and ply sheets.

Bundle: A package of shingles. There are typically 3, 4 or 5 bundles per square.

Butt edge: The lower edge of the shingle tabs. (See Figure A.)

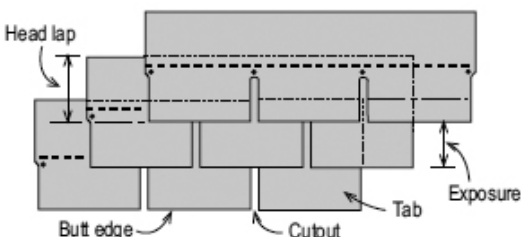

Figure A

Cap Sheet: A mineral surfaced material that is used by itself or as the top layer of multiple roof covering systems.

Caulk: To fill a joint with mastic or asphalt cement to prevent leaks.

Cement: See Asphalt Roof Cement.

Chalk Line: A line made on the roof by snapping a taut string or cord dusted with chalk. Used for alignment purposes.

Class “A”: The highest fire test classification for roofing as per ASTM E108 or UL790. Indicates roofing is able to withstand severe exposure to fire originating from sources outside the building.

Class “B”: Fire test classification that indicates roofing material is able to withstand moderate exposure to fire originating from sources outside the building.

Class “C”: Fire test classification that indicates roofing material is able to withstand light exposure to fire originating from sources outside the building.

Closed Cut Valley: A method of valley treatment in which shingles from one side of the valley extend across the valley while shingles from the other side are trimmed 2" from the valley centerline. The valley flashing is not exposed.

Coating: A layer of viscous asphalt applied to the base material into which granules or other surfacing is embedded.

Collar: Pre-formed flange placed over a vent pipe to seal the roof around the vent pipe opening. Also called a vent sleeve.

Concealed Nail Method: Application of roll roofing in which all nails are driven into the underlying course of roofing and covered by a cemented, overlapping course. Nails are not exposed to the weather.

Condensation: The change of water from vapor to liquid when warm, moisture-laden air comes in contact with a cold surface.

Counter Flashing: That portion of the flashing attached to a vertical surface to prevent water from migrating behind the base flashing.

Course: A row of shingles or roll roofing running the length of the roof.

Coverage: The number of layers of material between the exposed surface of the roofing and the deck; i.e., single coverage, double coverage, etc.

Cricket: A peaked saddle construction at the back of a chimney to prevent accumulation of snow and ice and to deflect water around the chimney.

Cutout: The open portions of a strip shingle between the tabs. (See Figure A.)

Deck: The surface, installed over the supporting framing members, to which the roofing is applied. The minimum thickness of a wood deck is a 15/32" exterior grade plywood or 7/16" exterior grade OSB or as required by local building codes.

Dormer: A framed window unit projecting through the sloping plane of a roof. (See Figure B.)

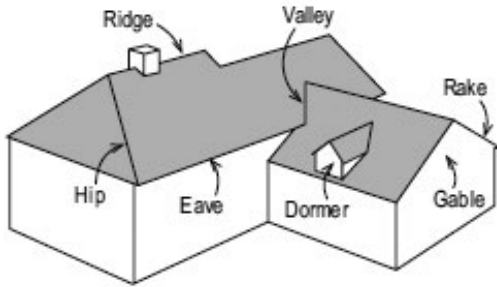
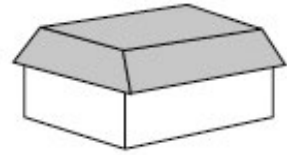

Figure B



Mansard Roof

Double Coverage: Application of asphalt roofing such that the lapped portion is at least 2" wider than the exposed portion, resulting in two layers of roofing material over the deck.

Downspout: A pipe for draining water from roof gutters. Also called a leader.

Drip Edge: A corrosion-resistant, non-staining material used along the eaves and rakes to allow water run-off to drip clear of underlying construction.

Eave: The horizontal, lower edge of a sloped roof. (See Figure B.)

Eave Flashing: Additional layer of roofing material applied at the eaves to help prevent damage from water back-up.

Exposed Nail Method: Application of roll roofing in which all nails are driven into the cemented, overlapping course of roofing. Nails are exposed to the weather.

Exposure: That portion of the roofing exposed to the weather after installation. (See Figure A.)

Felt: Fibrous material saturated with asphalt and used as an underlayment or sheathing paper.

Fiberglass Mat: An asphalt roofing base material manufactured from glass fibers.

Flashing: Pieces of metal used to prevent seepage of water into a building around any intersection or projection in a roof such as vent pipes, chimneys, adjoining walls, dormers and valleys. Galvanized metal flashing should be minimum 26-gauge.

Flashing cement: See Asphalt Roof Cement.

FM Global: A service mark of the Factory Mutual Insurance Company.

Free-Tab Shingles: Shingles that do not contain factory-applied strips or spots of self-sealing adhesive.

Gable: The upper triangular portion of a sidewall that comes to a point at the ridge of a double sloping roof. (See Figure B.)

Gable Roof: A simple two-sided roof above a gable.

Gambrel Roof: A type of roof containing two sloping planes of different pitch on each side of the ridge. The lower plane has a steeper slope than the upper. Contains a gable at each end.

Granules: Typically ceramic-coated colored crushed rock that is applied to the exposed surface of asphalt roofing products.

Gutter: The trough that channels water from the eaves to the downspouts.

Head Lap: Shortest distance from the butt edge of an overlapping shingle to the upper edge of a shingle in the second course below. The triple coverage portion of the top lap of strip shingles. (See Figure A.)

Hexagonal Shingles: Shingles that have the appearance of a hexagon after installation.

Hip: The inclined external angle formed by the intersection of two sloping roof planes. Runs from the ridge to the eaves. (See Figure B.)

Hip Roof: A type of roof containing sloping planes on each of four sides. Contains no gables.

Hip Shingles: Shingles used to cover the inclined external angle formed by the intersection of two sloping roof planes.

Ice Dam: Condition formed at the lower roof edge by the thawing and re-freezing of melted snow on the overhang. Can force ponded water up and under shingles, causing leaks.

Interlocking Shingles: Individual shingles that mechanically fasten to each other to provide wind resistance.

Laminated Shingles: Strip shingles containing more than one layer to create extra thickness. Also called three-dimensional shingles or architectural shingles.

Lap: To cover the surface of one shingle or roll with another.

Lap Cement: An asphalt-based cement (conforming to ASTM D3019) used to adhere overlapping plies of roll roofing.

Low Slope Application: Method of installing asphalt shingles on roof slopes 2"- 4" per foot.

Mansard Roof: A type of roof containing two sloping planes of different pitch on each of four sides. The lower plane has a much steeper pitch than the upper, often approaching vertical. (See Figure B.)

Masonry Primer: An asphalt-based primer used to prepare masonry surfaces for bonding with other asphalt products.

Mastic: See Asphalt Roof Cement.

Mid-ply Sheet: see Base-ply sheet.

Mineral Stabilizers: Finely ground limestone, slate, trap rock or other inert materials added to asphalt coatings for durability and increased resistance to fire and weathering.

Mineral-Surfaced Roofing: Asphalt shingles and roll roofing that are covered with granules.

Nesting: A method of reroofing with new asphalt shingles over old shingles in which the top edge of the new shingle is butted against the bottom edge of the existing shingle tab.

No-Cutout Shingles: Shingles consisting of a single, solid tab with no cutouts.

Non-Veneer Panel: Any wood-based panel that does not contain a laminated veneer and carries an APA span rating, such as wafer board or oriented strand board.

Open Valley: Method of valley construction in which shingles on both sides of the valley are trimmed along a chalk line snapped on each side of the valley. Shingles do not extend across the valley. Valley flashing is exposed.

Organic Felt: An asphalt roofing base material manufactured from cellulose fibers.

Overhang: That portion of the roof structure that extends beyond the exterior walls of a building.

Pallets: Wooden platforms used for storing and shipping bundles of shingles.

Pitch: The degree of roof incline expressed as the ratio of the rise, in feet, to the span, in feet; pitch is 1/2 of slope.

Ply: A layer of roofing (i.e., one-ply, two-ply).

Ponding: The accumulation of water after rainfall at low-lying areas on a roof that remains wet when other parts of the roof have dried.

Racking: Roofing application method in which shingle courses are applied vertically up the roof.

Rafter: The supporting framing member immediately beneath the deck, sloping from the ridge to the wall plate.

Rake: The inclined edge of a sloped roof over a wall. (See Figure B.)

Random-Tab Shingles: Shingles on which tabs vary in size and exposure.

Release Tape: A plastic or paper strip that is applied to the back of self-sealing shingles. This strip prevents the shingles from sticking together in the bundles, and need not be removed for application.

Reroofing: The process of recovering or replacing an existing roofing system.

Ridge: The uppermost, horizontal external angle formed by the intersection of two sloping roof planes. (See Figure B.)

Ridge Shingles: Shingles used to cover the horizontal external angle formed by the intersection of two sloping roof planes.

Rise: The vertical distance from the eaves line to the ridge.

Roll Roofing: Asphalt roofing products manufactured in roll form.

Roofing Tape: An asphalt-saturated tape used with asphalt cements for flashing and patching asphalt roofing.

Run: The horizontal distance from the eaves to a point directly under the ridge. One half the span.

Saturant: Asphalt used to impregnate an organic felt base material.

Saturated Felt: An asphalt-impregnated felt used as an underlayment between the deck and the roofing material.

Self-Adhering Shingle Underlayment: A self-adhering waterproofing shingle underlayment designed to protect against water infiltration due to ice dams or wind driven rain.

Self-Sealing Shingles: Shingles containing factory-applied strips or spots of self-sealing adhesive.

Self-Sealing Strip or Spot: Factory-applied adhesive that bonds shingle courses together when exposed to the heat of the sun after application.

Selvage: That portion of roll roofing overlapped by the succeeding course to obtain single or double coverage at the lap.

Shading: Slight differences in shingle color that may occur as a result of normal manufacturing operations.

Sheathing: See Deck.

Shed Roof: A roof containing only one sloping plane. Has no hips, ridges, valleys or gables.

Single Coverage: Asphalt roofing that provides one layer of roofing material over the deck.

Slope: The degree of roof incline expressed as the ratio of the rise, in inches, to the run, in feet.

Smooth-Surfaced Roofing: Roll roofing that is covered with ground talc or mica instead of granules (coated).

Soffit: The finished underside of the eaves.

Soil Stack: A vent pipe that penetrates the roof.

Span: The horizontal distance from eave to eave.

Square: A unit of roof measure covering 100 sq ft.

Square-Tab Shingles: Shingles on which tabs are all the same size and exposure.

Standard Slope Application: Method of installing asphalt shingles on roof slopes 4" - 21" per foot.

Starter Strip: Asphalt roofing applied at the eave that provides protection by filling in the spaces under the cutouts and joints of the first course of shingles.

Steep Slope Application: Method of installing asphalt shingles on roof slopes greater than 21" per foot.

Step Flashing: Base flashing application method used where a vertical surface meets a sloping roof plane.

Strip Shingles: Asphalt shingles that are approximately three times as long as they are wide.

Tab: The exposed portion of strip shingles defined by cutouts. (See Figure A.)

Talc: See Back Surfacing.

Tear Off: To remove an existing roofing system down to the structural deck.

Telegraphing: A shingle distortion that may arise when a new roof is applied over an uneven surface.

Three-Dimensional Shingles: See laminated shingles.

Top Lap: That portion of the roofing covered by the succeeding course after installation. (See Figure A.)

UL: Underwriters Laboratories, LLC

UL Label: Label displayed on packaging to indicate the level of fire and/or wind resistance of asphalt roofing.

Underlayment: Asphalt saturated felt or specially engineered synthetic material used beneath roofing to provide additional protection for the deck.

Valley: The internal angle formed by the intersection of two sloping roof planes. (See Figure B.)

Vapor Retarder: Any material used to prevent the passage of water vapor.

Vent: Any outlet for air that protrudes through the roof deck such as a pipe or stack. Any device installed on the roof, gable or soffit for the purpose of ventilating the underside of the roof deck.

Vent Sleeve: See Collar.

Woven Valley: Method of valley construction in which shingles from both sides of the valley extend across the valley and are woven together by overlapping alternate courses as they are applied. The valley flashing is not exposed.

PEACE OF MIND FOR YOUR BIGGEST INVESTMENT - YOUR HOME

TOTAL PROTECTION. TOTAL CONFIDENCE.™



It takes more than just shingles to protect your home. It takes an integrated system of components and layers designed to withstand the forces of nature outside while controlling temperature and humidity inside.

The Owens Corning® Total Protection Roofing System® ^ gives you the assurance that all of your Owens Corning® roofing components are working together to help increase the performance of your roof — and to enhance the comfort and enjoyment of those who live beneath it.

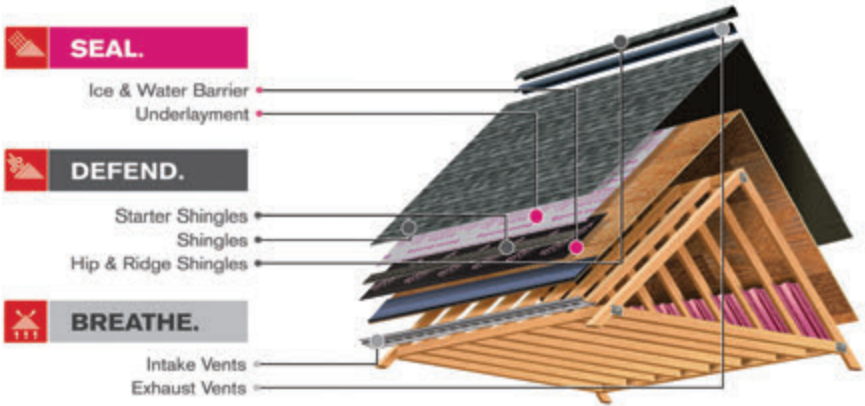

OWENS CORNING ROOFING AND ASPHALT, LLC

ONE OWENS CORNING PARKWAY
TOLEDO, OHIO, USA 43659

1-800-GET-PINK®
www.owenscorning.com/roofing



Pub.No. 10020940. Printed in U.S.A. March 2016. THE PINK PANTHER™ & © 1964–2016 Metro-Goldwyn-Mayer Studios Inc. All Rights Reserved. The color PINK is a registered trademark of Owens Corning. © 2016 Owens Corning. All Rights Reserved.

SureNail® Technology is proprietary with U.S. and foreign protection including U.S. Patent Nos. 7,836,654; 8,156,704; 8,181,413; 8,240,102; 8,430,983; 8,607,521; 8,623,164; 8,752,351; 8,991,130; 9,121,178; and other patents pending.

SureNail® Technology is not a guarantee of performance in all weather conditions.

2015 SureNail® Technology Performance Comparison Contractor Survey, December, 2015

^ Excludes non-Owens Corning® roofing products such as flashing, fasteners and wood decking.